

Color Inkjet Printer

Tx300P-1800

Tx300P-1800 MkII

Operation Manual

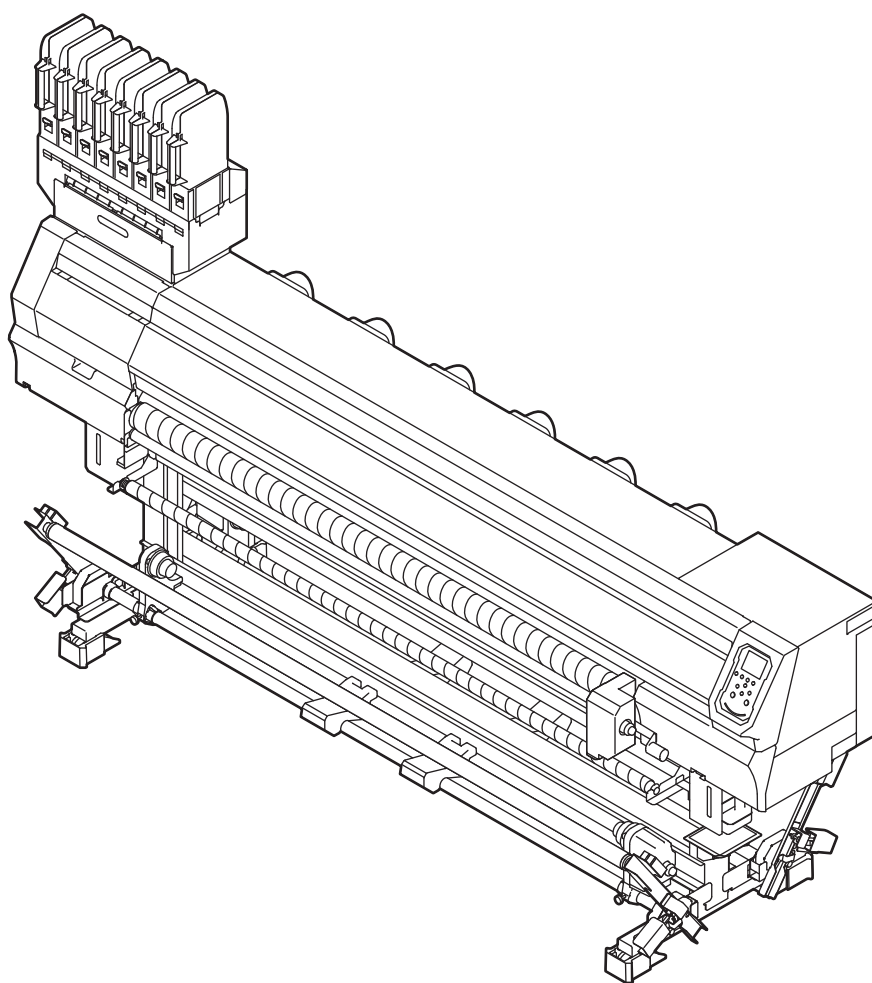

You can also download the latest manual from our website.

MIMAKI ENGINEERING CO., LTD.

<https://mimaki.com/>

D202937-34

Original instructions

TABLE OF CONTENTS

Forword	v
DISCLAIMER OF WARRANTY	v
On This Operation manual	v
FCC Statement (USA)	v
Interference to televisions and radios	v
About usable ink	v
Safety Precautions	vi
Symbols	vi
Safety interlock	ix
Warning labels	x

Chapter 1 Before Use

Moving This Machine	1-2
Where to Install This Machine	1-2
Working Environmental Temperature.....	1-2
Moving This Machine	1-2
Names of Parts and Functions	1-3
Front side view	1-3
Rear Side and Right Side of the Machine	1-4
Front side (under) view (Tx300P-1800 MkII Only)	1-5
Operation Panel	1-6
Media sensor.....	1-8
Carriage.....	1-8
Capping station	1-8
Pinch rollers and Grit rollers	1-8
Connecting Cables	1-9
Connecting USB2.0 Interface Cable	1-9
Connecting the LAN cable.....	1-9
Connecting the power cable.....	1-10
Setting Ink	1-11
Caution in handling of ink packs.....	1-13
Turning the Power ON/OFF	1-15
Turning the Power ON.....	1-15
Turning the Power OFF.....	1-15
Media	1-16
Usable sizes of media	1-16
Switching between cloth media and paper media (transfer paper) (Tx300P-1800 MkII only)	1-16
Caution in handling of media.....	1-16
Limited media	1-17
Menu mode	1-18

Chapter 2 Basic Operations

Workflow	2-2
Preparing the main unit	2-4
Platen change (Tx300P-1800 MkII only)	2-4
Changing with the cloth media platen	2-4
Attaching the paper(transfer paper) platen.	2-5
Spacer installation (cloth media)	2-7

Turning on the main power supply	2-8
Adjusting the Head Height.....	2-8
Feeding/ Take-up device	2-9
Media Edge Guide.....	2-10
How to adjust the weight of feeding/ take-up tension-bar (cloth media)..	2-11
Setting the torque limiter (cloth media).....	2-14
Setting a Media	2-16
Setting up the roll media (cloth media).....	2-16
Setting up the roll media (transfer paper) (Tx300P-1800 MkII only)	2-22
Setting leaf media (cloth media).....	2-24
Setting leaf media (Transfer Paper) (Tx300P-1800 MkII only).....	2-25
Media information setup	2-26
Print adjustment	2-28
Changing the printing origin	2-28
Test Printing	2-28
Head Cleaning.....	2-29
Feed settings.....	2-30
If the Positions of Dots Shift... ..	2-30
Adjustment to Refine Finished Printing	2-32
Flow of media feeding correction	2-32
Printing Data	2-33
Starting a Printing Operation	2-33
Stopping a Printing Operation	2-33
Deleting Received Data (Data Clear)	2-33
Behavior after printing has been completed	2-33
Media removal	2-34
Removing the roll media	2-34

Chapter 3 Setup

About SETUP MENU	3-2
SETUP MENU table	3-3
Register the optimal print conditions to match the use.....	3-4
Setting of Media Correction	3-5
If the Positions of Dots Shift... ..	3-6
Setting of Logical Seek.....	3-7
Setting of Overprint	3-7
Setting of Drying Time	3-7
Setting of Left and Right Margins	3-8
Setting of Vacuum Fan	3-8
Setting of Feed Speed.....	3-8
Setting of MAPS4	3-9
Setting Auto Cleaning.....	3-10
Setting Interval wiping	3-11
Setting External heater	3-11
About MACHINE SETUP MENU	3-12
MACHINE SETUP MENU table	3-13
Setting a AUTO Power-off	3-14
Setting Feeding and Take-up unit	3-14
Setting Top Blower	3-15
Setting the Display of Media Residual.....	3-16
Setting the PG Drop Adjust	3-16

Setting the Media Detection	3-16
Setting the Drying Feed.....	3-17
Setting a LANGUAGE	3-17
Setting Time	3-17
Setting Unit (Temperature/ Length).....	3-18
Setting a KEY BUZZER.....	3-18
Setting the VIEW FEED	3-18
Setting the amount of blank space between printed lines	3-18
Setting the SPACE FEED MODE.....	3-19
Set the network	3-19
Setting event mail function	3-20
Initializing the Settings.....	3-23
About NOZZLE CHECK MENU	3-24
INFORMATION MENU table.....	3-24
Printing Check Flow	3-25
Printing Operations at “Nozzle Missing” Judgment and Error Occurrence 3-25	
Setting the Printing Check.....	3-26
Setting the NOZZLE RECOVERY	3-26
Setting the Judgement Condition	3-26
About INFORMATION MENU	3-27
INFORMATION MENU table.....	3-27
Displaying the Information.....	3-28

Chapter 4 Maintenance

Maintenance	4-2
When to care	4-2
Precautions for Maintenance.....	4-3
About Cleaning Solution.....	4-3
Cleaning the Exterior Surfaces.....	4-3
Cleaning the Media Sensor	4-3
Cleaning folding bar (take-up side)	4-4
Cleaning the tension roller.....	4-4
Cleaning the Ink receiving spacer	4-4
Cleaning the Platen	4-4
Cleaning the Fabric Retainer / Media press	4-6
Cleaning of grit roller	4-6
About MAINTENANCE MENU	4-8
MAINTENANCE MENU at-a-glance.....	4-9
Maintaining the Capping Station	4-10
Cleaning the Wiper and Cap	4-10
Cleaning the Cap Absorber	4-12
Washing the Head Nozzle.....	4-12
Washing the Ink Discharge Passage	4-13
When the Machine Is Not Used for a Long Time	4-14
Cleaning the Ink Head and the Area around It	4-16
Cleaning around the Ink Head.....	4-16
Clean the edge of the head nozzle surface	4-17

Nozzle Recovery Function	4-18
Reset the set value.....	4-19
Check the condition for which nozzle recovery cannot be performed .	4-19
Enabling or disabling nozzle recovery during a test print	4-20
Automatic Maintenance Function	4-21
Setting the Refreshing Intervals	4-21
Setting the Tube Wash Intervals	4-21
Setting the Cleaning Intervals and Type	4-22
Suspend the nozzle cleaning	4-22
Fill up Ink	4-22
Replacing consumables	4-23
Replacing the wiper	4-23
If a Waste Ink Tank Confirmation Message Appears	4-24
Replace the waste ink tank with another	4-24
Replacing the Cap Absorber	4-25
Replacing the Blow down fan filter	4-26
Replacing the Pinch roller	4-27
Replacing the Spout Rubber	4-28
Male Connector Absorbent for MBIS.....	4-29

Chapter 5 Troubleshooting

Troubleshooting	5-2
Power does not turn on	5-2
The machine does not start printing	5-2
Media get jammed / media is soiled	5-2
Image quality is poor	5-3
Nozzle is clogged	5-3
Ink IC warning appears	5-3
When the Ink Leakage Occurs	5-3
Warning / Error Messages	5-4
Warning messages.....	5-4
Error messages	5-7

Chapter 6 Appendix

Specifications	6-2
Machine specifications	6-2
Ink specifications	6-4
Setting orders of ink cartridges	6-5
Sheet for inquiry	6-6

Forword

Thank you for purchasing this MIMAKI Tx300P-1800/ Tx300P-1800 MkII color inkjet printer.

The Tx300P-1800 and Tx300P-1800 MkII are high-resolution color inkjet printers that can print on 1.8 m wide fabric or transfer paper (Tx300P-Mk II only).

Please read this manual carefully to ensure printing in accordance with your requirements.

DISCLAIMER OF WARRANTY

THIS LIMITED WARRANTY OF MIMAKI SHALL BE THE SOLE AND EXCLUSIVE WARRANTY AND IS IN LIEU OF ALL OTHER WARRANTIES, EXPRESS OR IMPLIED, INCLUDING, BUT NOT LIMITED TO, ANY IMPLIED WARRANTY OF MERCHANTABILITY OR FITNESS, AND MIMAKI NEITHER ASSUMES NOR AUTHORIZES DEALER TO ASSUME FOR IT ANY OTHER OBLIGATION OR LIABILITY OR MAKE ANY OTHER WARRANTY OR MAKE ANY OTHER WARRANTY IN CONNECTION WITH ANY PRODUCT WITHOUT MIMAKI'S PRIOR WRITTEN CONSENT.

IN NO EVENT SHALL MIMAKI BE LIABLE FOR SPECIAL, INCIDENTAL OR CONSEQUENTIAL DAMAGES OR FOR LOSS OF PROFITS OF DEALER OR CUSTOMERS OF ANY PRODUCT.

On This Operation manual

- This operation manual describes how to operate and maintain the Tx300P-1800 and Tx300P-1800 MkII printers.
- This manual applies to both the Tx300P-1800 and Tx300P-1800 MkII printers.
- The diagrams in this manual primarily illustrate the Tx300P-1800 model.
- Read this Operation manual carefully and understand them thoroughly to use.
- It is also necessary to keep this Operation manual on hand.
- This Operation manual has been carefully prepared for your easy understanding.
However, please do not hesitate to contact a distributor in your district or our office if you have any inquiry.
- Description contained in this Operation manual are subject to change without notice for improvement.
- In the case when this Operation manual should be illegible due to destruction or lost by fire or breakage, purchase another copy of the Operation manual from our office.
- You can also download the latest manual from our website.

FCC Statement (USA)

This equipment has been tested and found to comply with the limits for a Class A digital device, pursuant to Part 15 of the FCC Rules. These limits are designed to provide reasonable protection against harmful interference when the equipment is operated in a commercial environment. This equipment generates, uses and can radiate radio frequency energy and, if not installed and used in accordance with the Operation manual, may cause harmful interference to radio communications.

Operation of this equipment in a residential area is likely to cause harmful interference in which case the user will be required to correct the interference at his own expense.

In the case where MIMAKI-recommended cable is not used for connection of this device, limits provided by FCC rules can be exceeded.

To prevent this, use of MIMAKI-recommended cable is essential for the connection of this printer.

Interference to televisions and radios

The product described in this manual generates high frequency when operating.

The product can interfere with radios and televisions if set up or commissioned under improper conditions.

The product is not guaranteed against any damage to specific-purpose radio and televisions.

The product's interference with your radio or television will be checked by turning on/off the power switch of the product.

In the event that the product is the cause of interference, try to eliminate it by taking one of the following corrective measures or taking some of them in combination.

- Change the orientation of the antenna of the television set or radio to find a position without reception difficulty.
- Separate the television set or radio from this product.
- Plug the power cord of this product into an outlet which is isolated from power circuits connected to the television set or radio.

About usable ink

You can use aqueous Dye Sublimation ink/ Disperse dye ink/ Textile pigment ink/ Acid-dye ink/ Reactive-dye ink/ Dye Sublimation Transfer ink(Tx300P-1800 MkII Only) for this machine.



- For usable ink, refer to P.6-4 "Ink specifications" and P.6-5 "Setting orders of ink cartridges".

Reproduction of this manual is strictly prohibited.
All Rights Reserved.Copyright











Safety Precautions

Symbols

Symbols are used in this Operation Manual for safe operation and for prevention of damage to the machine. The indicated sign is different depending on the content of caution.

Symbols and their meanings are given below. Please follow these instructions as you read this manual.

Examples

Explanation	
	Failure to observe the instructions given with this symbol can result in death or serious injuries to personnel. Be sure to read it carefully and use it properly.
	Failure to observe the instructions given with this symbol can result in injuries to personnel or damage to property.
	Important notes in use of this machine are given with this symbol. Understand the notes thoroughly to operate the machine properly.
	Useful information is given with this symbol. Refer to the information to operate the machine properly.
	Indicates the reference page for related contents.
	The symbol "  " indicates that the instructions must be observed as strictly as the CAUTION instructions (including DANGER and WARNING instructions). A sign representing a precaution (the sign shown at left warns of hazardous voltage) is shown in the triangle.
	The symbol "  " indicates that the action shown is prohibited. A sign representing a prohibited action (the sign shown at left prohibits disassembly) is shown in or around the circle.
	The symbol "  " indicates that the action shown must be taken without fail or the instructions must be observed without fail. A sign representing a particular instruction (the sign shown at left instructs to unplug the cable from the wall outlet) is shown in the circle.

Warning for Use

 **WARNING**



-  • The set of power cables provided with this machine is for use with this machine only, and cannot be used with other electrical devices. Do not use any power cables other than the ones provided with the machine. Failure to observe those instructions may result in fire or electric shocks.

 **WARNING**

- Take care not to damage, break or work upon the power cable. If a heavy material is placed on the power cable, or if it is heated or pulled, the power cable can break, thus resulting in fire or electric shocks.

-  • Do not use this machine in an environment where humidity is high or the machine may get wet. Using the machine under such environment may result in fire or electric shock, or cause malfunction.
- Use of the machine under an abnormal condition where it produces smoke or strange smell can result in fire or electric shocks. If such an abnormality is found, be sure to turn off the power switch immediately and unplug the cable from the wall outlet. Check first that the machine no longer produces smoke, and then contact your distributor or a sales office of MIMAKI for repair.
- Never repair your machine by yourself since it is very dangerous for you to do so.
- Never disassemble or remodel the main unit of the machine or the ink cartridge. Disassembly or remodeling can result in an electric shock or breakdown of the machine.
- Do not use extension cords. Doing so may result in fire or electric shocks.
- Keep the power plug prong clear of any foreign object such as a piece of metal. Failure to do so may result in a fire or electric shocks.
- Do not plug too many leads into a single socket. Doing so may result in fire or electric shocks.
- Do not use the machine if the power cord or plug is damaged. Using the machine with damaged power cord may result in fire or electric shocks. Contact your service representative for replacement cord.
- Do not handle the power plug with wet hands. Doing so may result in electric shocks.
- In case of ink leakage, please turn off the main power, unplug the power cable and contact your local distributor, our sales office, or service center.
- Grasp by holding the plug itself when removing the power plug from wall outlet, and never hold by the cord. Holding and pulling the cord may damage the cord, leading to fire or electric shocks.

Hazardous Moving Parts

-  • Keep Fingers and Other Body Parts Away
- If a foreign object such as a small piece of metal or a liquid such as water gets inside the machine, turn off the machine and unplug the power cord immediately, then consult your service representative. Continuing to use the machine without proper maintenance or repair may result in fire or electric shocks.
- Do not use this machine in an area where children might be present.
-  • Keep children away from this machine.

Precautions in Use

CAUTION

Power supply

-  **Leave the breaker turned ON.**
Do not turn off the main power switch on the right side of this machine.

Notes on operation and handling

-  Objects or tools such as tweezers, cutters, or screwdrivers that react to magnetic fields may stick to the platen if used nearby.

For those using a pacemaker

-  Keep away from the platen. (The platen uses magnets.)

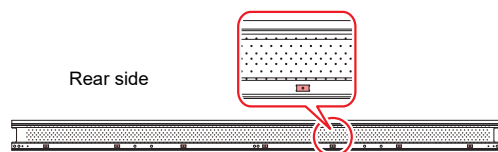

There are seven fixing magnets in front (lower side in this figure).

- If you feel unwell, move away from the printer (platen) immediately and seek medical assistance.

Handling of ink packs

-  Keep ink away from an open flame. Also keep the room well ventilated when you use or handle ink.
- If you get ink in your eyes, immediately wash your eyes with a lot of clean water for at least 15 minutes. In doing so, also wash eyes to rinse ink away completely. Then, consult a doctor as soon as possible.
- If anyone drinks ink by mistake, keep him or her quiet and see a doctor immediately. Do not allow him or her to swallow the vomit. Then contact the emergency number written in SDS.
- If you inhale a lot of vapor and feel bad, immediately move to a location of fresh air and then keep yourself warm and quiet. Then, consult a doctor as soon as possible.
- Store ink packs in a place that is out of the reach of children.
- If the ink adheres to your skin, use a large amount of water and soap or special detergent for skin to remove the ink.
- Be sure to store ink packs out of reach of children.

CAUTION

- When you removed the ink pack from the seat before it ends, wipe ink adhering to inside of the connector part of the ink pack with a cotton swab etc. If ink adhering to inside of the connector part may dry out, it may cause ink leakage when using it again.

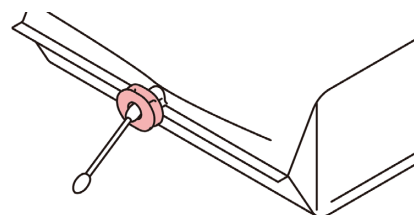

- When removing eco case from the seat, be sure to wear safety glasses etc. Ink may spatter and get in your eyes. Do not pull out and insert the middle cartridge again as much as possible.

 **CAUTION**

Note on maintenance



- When cleaning the ink-station or the heads, be sure to wear the included safety glasses and gloves
- When handling ink and cleaning solution, pay close attention to ventilation and be sure to wear the included safety glasses and gloves.
- Before using ink and cleaning solution, be sure to read the Safety Data Sheet (SDS).
- If you inhale a great deal of vapor and feel ill, immediately move to a location with plenty of fresh air, and keep yourself warm and quiet. Consult a doctor as soon as possible.
- The gloves supplied with the machine are disposable. When all the gloves are expended, purchase an equivalent product on the market.

Handling of the power cable



- Connect to a socket-outlet with determinate polarity.
- For PLUGGABLE EQUIPMENT, the socket-outlet shall be installed near the equipment and shall be easily accessible.
- Check the voltage of the wall outlet and the capacity of the circuit breaker before you plug the power cords. Plug each power cord to different outlet that has independent circuit breaker. If you plug more than one power cord to wall outlets that share the same circuit breaker, the power may be cut off by the breaker.
- Do not use the machine unless it is connected to a power supply that satisfies the displayed voltage condition.
- Unplug the cord from the wall outlet and remove dust from the power plug periodically, at least once a year. Failure to do so may result in fire or electric shocks.

Notes When Handling this machine



- Use the equipment in a well-ventilated or not-airtight room.
- Ventilate the room sufficiently before using the equipment.
- Do not place the equipment in a humid or dusty place. Otherwise, there is a risk of fire or electrical shock.
- Do not place the equipment in an unstable place such as on a shaky table and on a tilted surface. The equipment may fall over or drop and cause injury.
- To replace a printing media, be careful not to pinch your fingers or get injured.
- Do not leave the ink slot empty for a long time. Leaving it empty may dry the slot and solidify the ink in the machine, then the machine will become unable to supply ink.
- If ink packs are not set in the ink slot, an error message will display on the printer to set ink packs. Set the same colored ink cartridge as the ink used before.

 **CAUTION**

- Consult with the service shop about cleaning inside the equipment.
Leaving the equipment with dust inside without cleaning for a long time may cause a fire or device failure. Consult with the distributor or service shop for the cost of cleaning inside the equipment.
- To move the equipment, contact the nearest service shop.

CAUTIONS and NOTES

 **Warning**

Disposition of this machine

- Consult your sales or service representative for proper disposal of this machine. Otherwise, commission an industrial waste disposal company.

Protection of media from dust

- Store media in a bag. Wiping off dust accumulated on media will adversely affect the media due to static electricity.
- When leaving the workshop after the working hours, do not leave any media on the roll hanger. If any media is left on the roll hanger, it can get dusty.

Periodic replacement parts

- Some parts of this machine must be replaced with a new one periodically by service personnel. Be sure to make a contract with your distributor or dealer for After sale service to ensure a long life of your machine.

Handling of media

- Use media recommended by MIMAKI to ensure reliable, high-quality printing.
- Pay attention to the expansion and contraction of the media. Do not use media immediately after unpacking. The media can be affected by the room temperature and humidity, and thus it may expand and contract. The media have to be left in the atmosphere in which they are to be used for 30 minutes or more after unpacked.
- Do not use curled media.
The use of curled media can not only cause a media jam but also affect print quality.
Straighten the sheet of media, if significantly curled, before using it for printing. If a regular-sized coated sheet of media is rolled and stored, the coated side has to face outside.
- Do not leave the media with the heater ON for a long time.

Handling of ink packs

- The safety evaluation of this machine assumes that the ink recommended by this company is used. For safe usage of this machine, use the ink recommended by this company
- Never refill the ink pack with ink. Refilled ink pack can cause a trouble. Remember that MIMAKI assumes no responsibility for any damage caused by the use of the ink pack replenished with ink.
- If the ink pack is moved from a cold place to a warm place, leave it in the room temperature for three hours or more before using it.

Warning

- Open the ink pack just before installing it in the machine. If it is opened and left for an extended period of time, normal printing performance of the machine may not be ensured.
- Make sure to store ink packs in a cool and dark place.
- Store ink packs and waste ink bottle in a place that is out of the reach of children.
- Be sure to thoroughly consume the ink in the ink pack, once it is opened, within three months. If an extended period of time has passed away after opening the cartridge tank, printing quality would be poor.
- Neither pound the cartridge nor shake it violently, as doing so can cause leakage of ink.

• Consult your sales or service representative for proper disposal of ink cartridge, ink pack, and waste ink. When you dispose them by yourself, follow the regulations stipulated by the industrial waste disposer or the country or region you live in.

Notes on maintenance

- It is strongly recommended to use the machine in a room that is not dusty.
- Keep the front cover closed even when the machine is not printing. If not, dust can accumulate on the nozzles in the heads.
- Dust in the heads can also cause drops of ink to fall suddenly down on the media during printing. In such a case, be sure to clean up the heads.
- When cleaning the ink-station or the heads, make sure to wear the attached gloves and safety glasses.
- Perform wiping (removal of dust and paper powder) of the capping station and wiper frequently.

Cautions on Installation

CAUTION

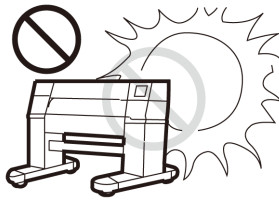
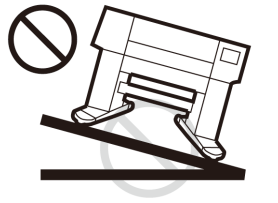
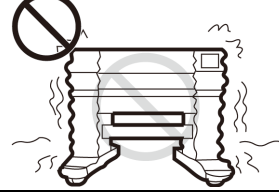
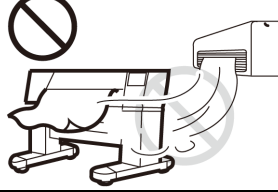
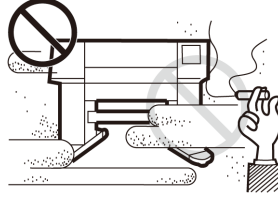
<p>A place exposed to direct sunlight</p>	<p>On an inclined surface</p>
	
<p>A place that vibrates</p>	<p>A place exposed to direct air flow from an air conditioner or the like.</p>
	
<p>A place where temperature or humidity varies significantly</p>	<p>Around a place where fire is used</p>
<p>!</p> <ul style="list-style-type: none"> • Use the machine under the following environmental conditions: • Operating environment: 20 to 30 °C (68 to 86 °F) 35 to 65 % (Rh) 	

Safety interlock



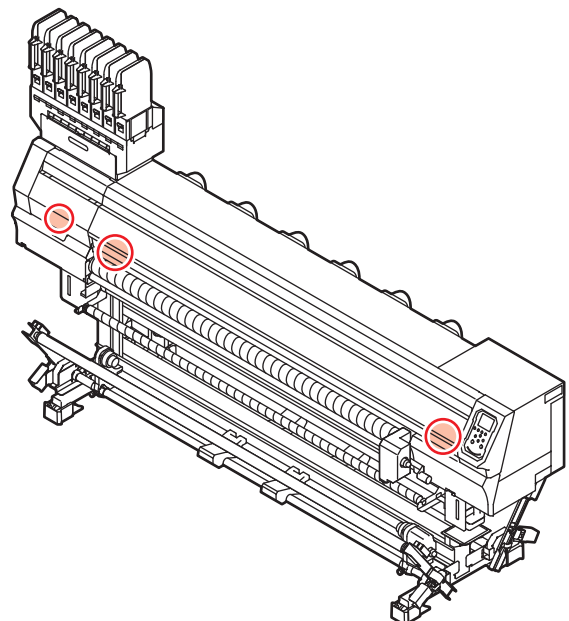





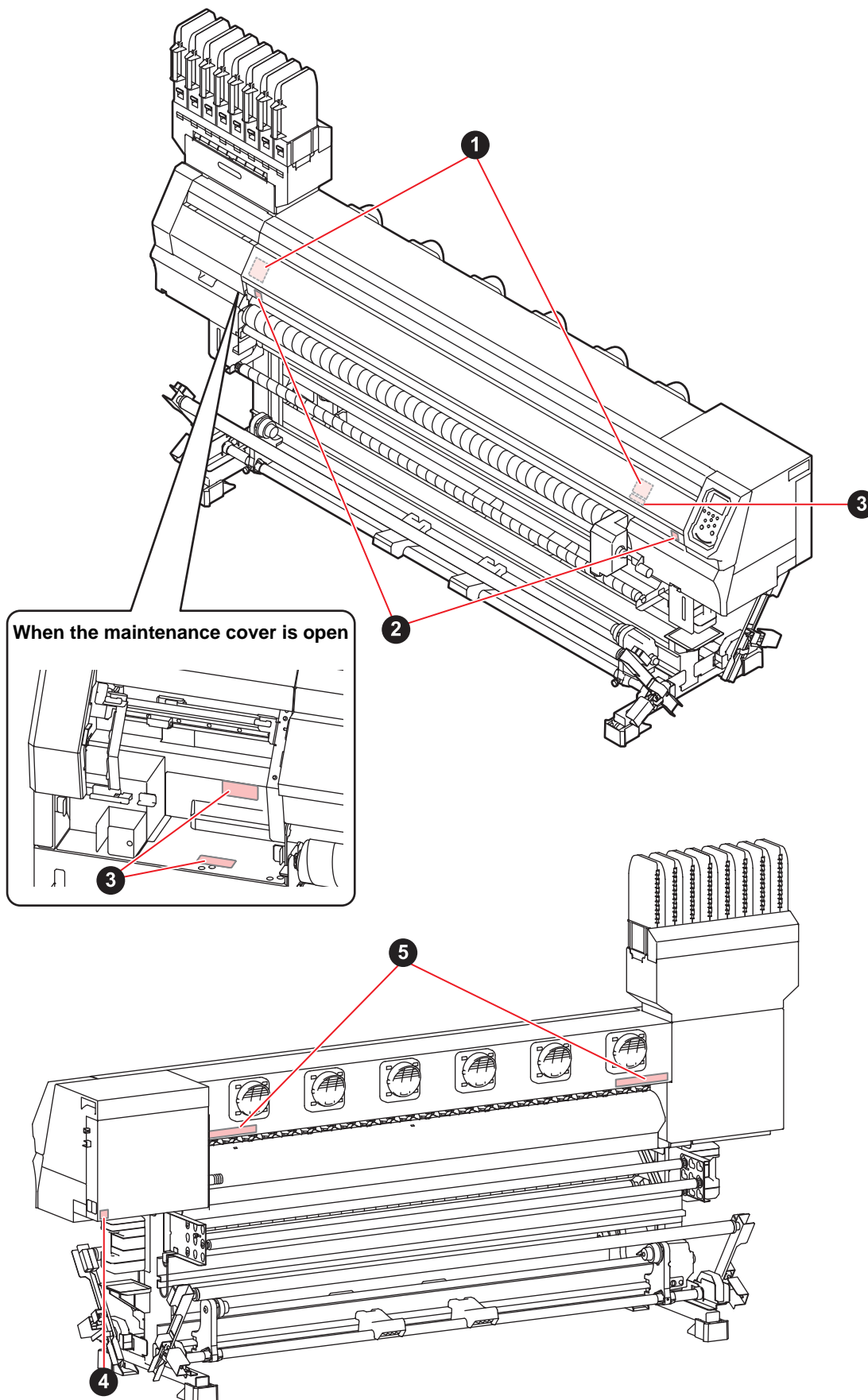

This machine is equipped with interlocks to terminate the operation for your safety when the cover opens during printing etc. (red circle parts in the figure below).

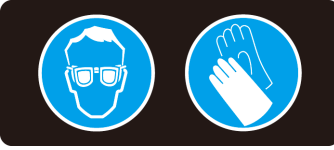

Warning labels

Warning labels are stuck on the machine. Be sure to fully understand the warning given on the labels. If a warning label is illegible due to stains or has come off, purchase a new one from a distributor or our sales office.



No.	Reorder	Label							
1	M910931	 <p>CAUTION ATTENTION</p> <p>COVER HAZARD May result in severe injury. When open and close the cover, hold a cover until the end.</p> <p>COUVERCLE-DANGER Peut entraîner de graves blessures. Lors de l'ouverture ou de la fermeture du couvercle, tenir le couvercle jusqu'à la fin.</p> <p>カバー急落下あり 指を挟まれると、ケガや骨折の恐れあり。 カバーの開閉は、最後まで手を添えて行ってください。</p> <p>M910931</p>							
2	M907833								
3	M903330								
4	M907935								
5	M905811	 <table border="1" data-bbox="464 1041 1342 1160"> <tr> <td></td> <td></td> <td>警告 手指和身体请勿靠近运转部位，以免造成危险</td> <td>警告 危険な稼働部 指や体を近づけないように</td> <td>WARNING -HAZARDOUS MOVING PARTS- Keep fingers and other body parts away.</td> <td>WAARSCHUWING GEFÄHRLICHE BEWEGLICHE TEILE Finger und andere Körperteile fernhalten.</td> <td>AVERTISSEMENT PIECES MOBILES DANGEREUSES Doigts et autres parties du corps sont hors de portée.</td> </tr> </table>			警告 手指和身体请勿靠近运转部位，以免造成危险	警告 危険な稼働部 指や体を近づけないように	WARNING -HAZARDOUS MOVING PARTS- Keep fingers and other body parts away.	WAARSCHUWING GEFÄHRLICHE BEWEGLICHE TEILE Finger und andere Körperteile fernhalten.	AVERTISSEMENT PIECES MOBILES DANGEREUSES Doigts et autres parties du corps sont hors de portée.
		警告 手指和身体请勿靠近运转部位，以免造成危险	警告 危険な稼働部 指や体を近づけないように	WARNING -HAZARDOUS MOVING PARTS- Keep fingers and other body parts away.	WAARSCHUWING GEFÄHRLICHE BEWEGLICHE TEILE Finger und andere Körperteile fernhalten.	AVERTISSEMENT PIECES MOBILES DANGEREUSES Doigts et autres parties du corps sont hors de portée.			

Chapter 1

Before Use



This chapter

describes the items required to understand before use, such as the name of each part of the machine or the installation procedures.

Moving This Machine	1-2	Connecting the power cable	1-10
Where to Install This Machine	1-2	Setting Ink	1-11
Working Environmental Temperature	1-2	Caution in handling of ink packs	1-13
Moving This Machine	1-2	Turning the Power ON/OFF	1-15
Names of Parts and Functions.....	1-3	Turning the Power ON	1-15
Front side view	1-3	Turning the Power OFF	1-15
Rear Side and Right Side of the Machine ...	1-4	Media	1-16
Front side (under) view (Tx300P-1800 MkII On-ly)	1-5	Usable sizes of media	1-16
Operation Panel	1-6	Switching between cloth media and paper media (transfer paper) (Tx300P-1800 MkII only)	1-16
Media sensor	1-8	Caution in handling of media	1-16
Carriage	1-8	Limited media	1-17
Capping station	1-8	Menu mode	1-18
Pinch rollers and Grit rollers	1-8		
Connecting Cables.....	1-9		
Connecting USB2.0 Interface Cable	1-9		
Connecting the LAN cable	1-9		

Moving This Machine

Where to Install This Machine

Secure a suitable installation space before assembling this machine. The place of installation must have enough space for not only this machine itself, but also for the printing operation.

Model	Width	Depth	Height	Gross weight
Tx300P-1800	3,200 mm (126.0 in)	965 mm (38.0 in)	1,857 mm (73.1 in)	255 kg (562.2 lb)
Tx300P-1800 MkII				260kg (573.0 lb)

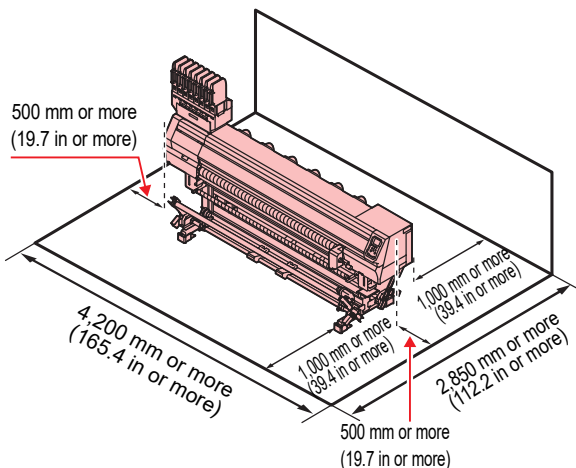

Working Environmental Temperature

Use this machine in an environment of 20 to 30°C (68 to 86°F) to ensure reliable printing.

Moving This Machine

Move this machine according to the following steps when this machine needs to be moved on the same step-free floor.



- When the machine is moved to any place other than on the same step-free floor, contact your distributor or our service office. If you move it by yourself, failure or damage may occur. Be sure to request your distributor or our service office to move this machine.



- When moving this machine, take care that it does not receive a significant impact.
- Be sure to lock the casters after moving of this machine.

1 Remove the caster blocks.

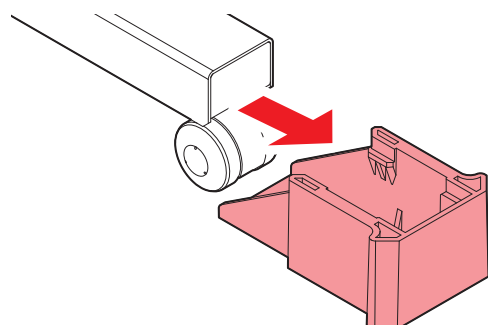

2

Raise the take-up and feeding legs.

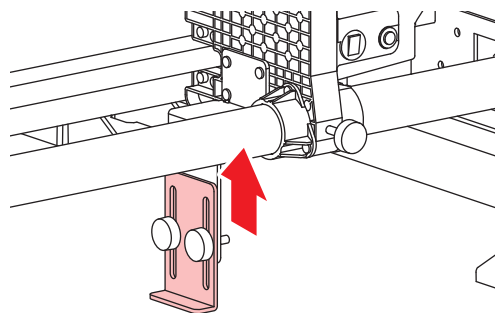

3

Move this machine as shown in the figure.

- For safety, be sure to operate it with 6 people or more.
- Do not push the cover to move this machine since the cover may be broken.

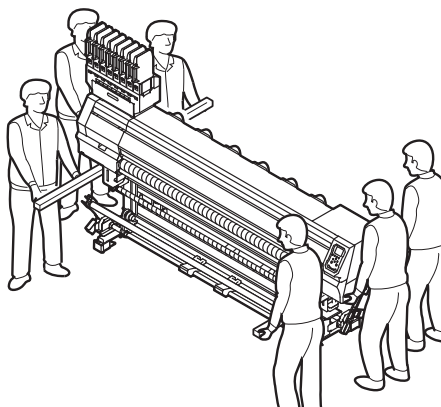

4

Lower the take-up and feeding legs.

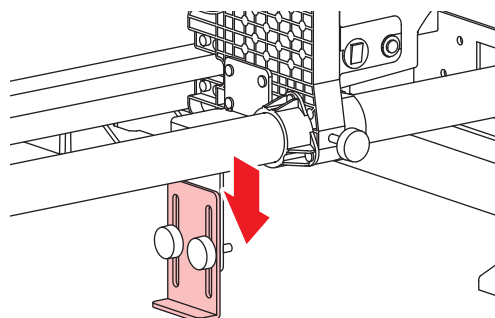

5

Reinstall the caster blocks.

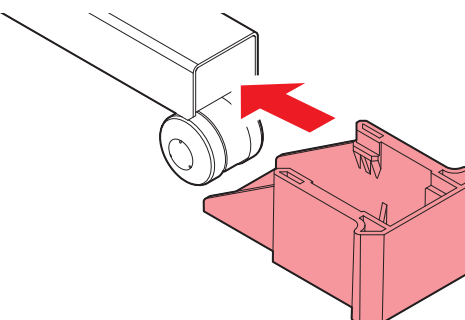

Names of Parts and Functions

Front side view

The following figure shows the Tx300P-1800 MkII. It differs slightly from the Tx300P-1800.

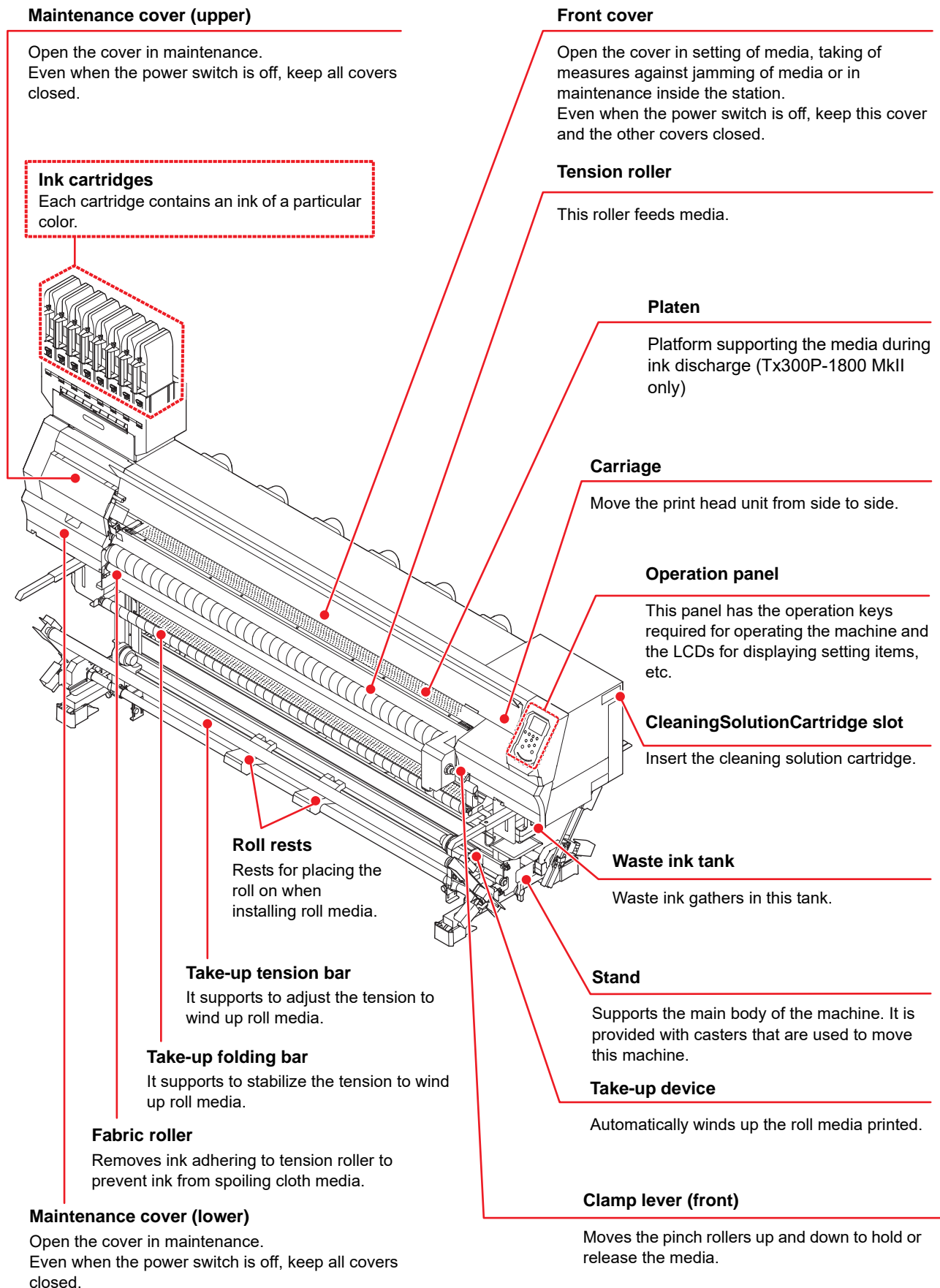

Rear Side and Right Side of the Machine

The following figure shows the Tx300P-1800 MkII. It differs slightly from the Tx300P-1800.

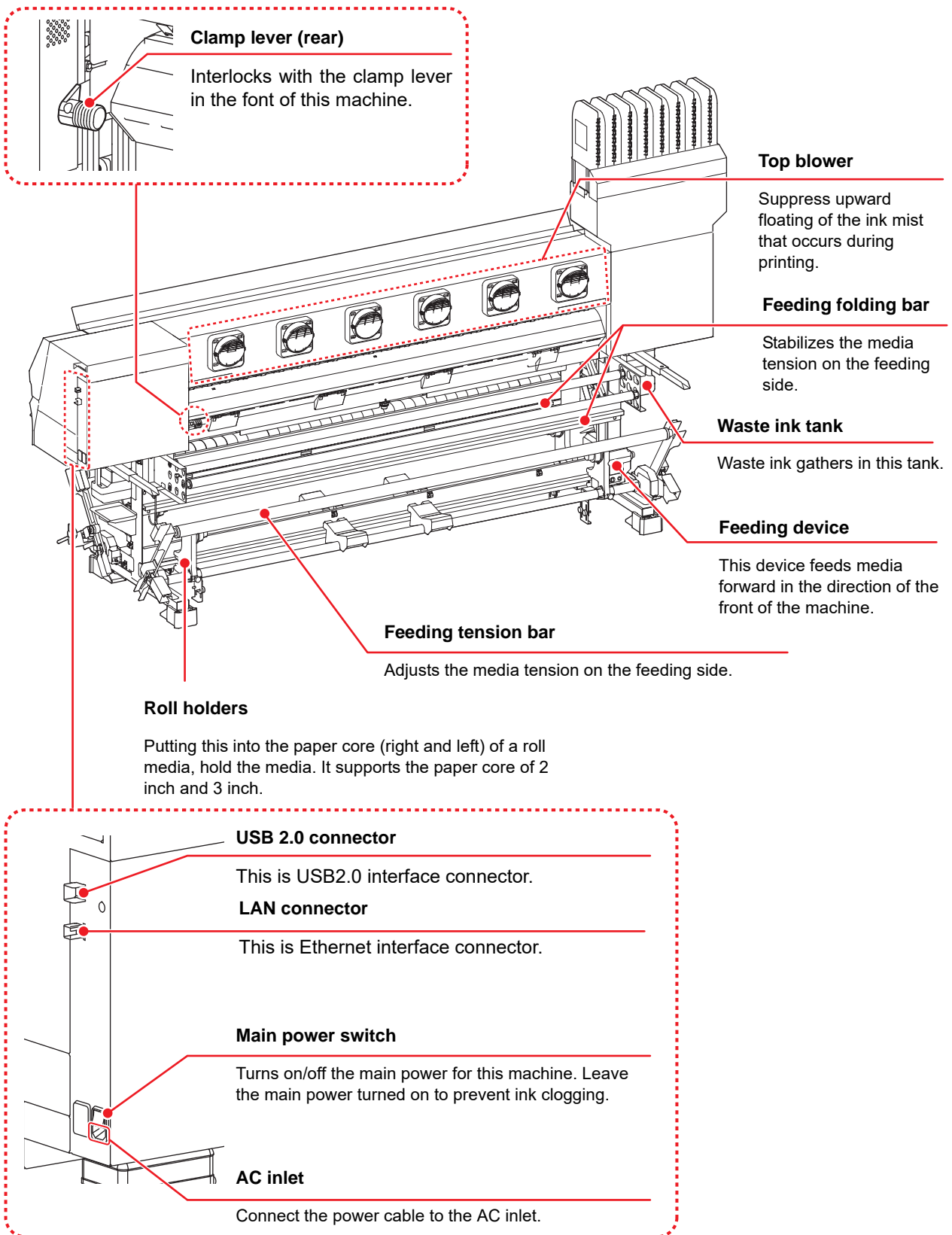

Front side (under) view (Tx300P-1800 MkII Only)

Platen holder

The Tx300P-1800 MkII has a platen holder below the main unit for storing the platen when removed.

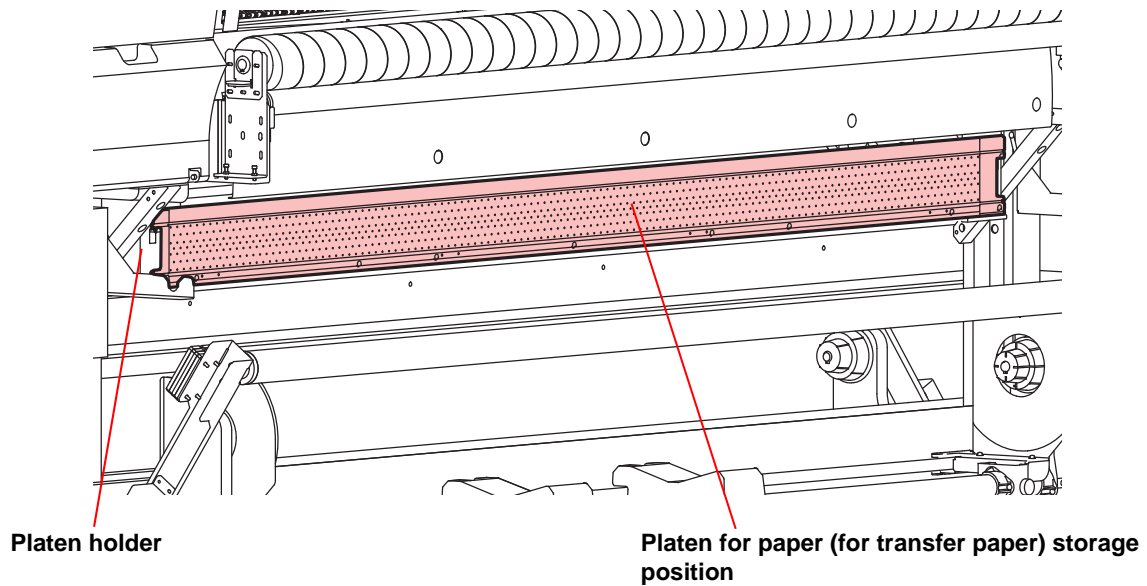

Removable platen for paper (for transfer paper)

Used when printing on paper media (transfer paper).

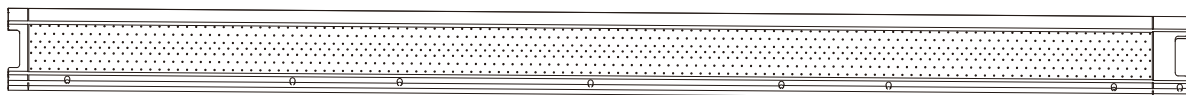

Media edge guide

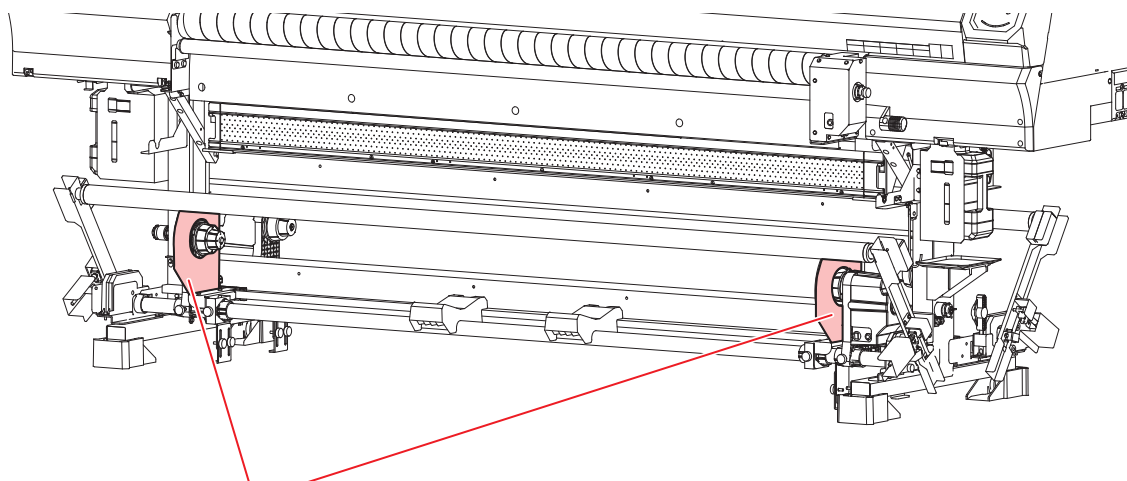

Media Edge Guide

Prevents lateral deviation of the roll media edges during media taking-up.

Operation Panel

Use the operation panel to make settings for printing or operate this machine.

SEL key
Changes over the functions of the function keys ([FUNC1] to [FUNC3]).

[FUNC1] / [FUNC2] / [FUNC3] key
Press this to set various functions or to do test printing. The function keys' functions are changed each

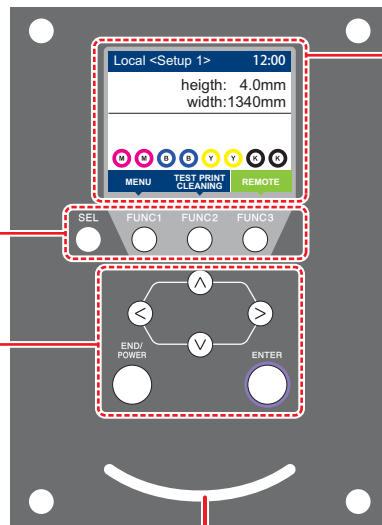

Display

- Displays the following items:
- Printer status
 - Set media width
 - Ink status *1
 - Functions assigned to [FUNC1] to [FUNC3] *2

JOG key (Left, Right, Up, Down arrow icons)
Use these keys to shift the carriage or the media in [LOCAL]. Also use them to select an item of printing conditions.

[END/POWER] key
Cancels the last input value or returns the setting menu to the immediate higher level of the hierarchy. Also, press this to turn the power on or off. (Give it a long press to turn the power off.)

[ENTER] key
Registers the last input value as the setting value or goes to the immediate lower level of the hierarchy.

Status indicator lamp

Indicates the machine's status (printing, error occurred, etc).

Condition of Lamp	Condition of machine
OFF	Machine is in LOCAL mode, no print data has been received, and no errors have occurred.
Lit steady Light blue	Switched to REMOTE mode.
Flashing Light blue	Currently printing.
	In test printing: printing a pattern stored inside the machine.
Lit steady blue	Print data still remains in the machine.
Flashing red	Error has occurred.
Lit steady red	Error (SYSTEM HALT) has occurred.
Lit steady yellow	Firmware is being updated.



- The power switch under the operation panel lights in blue when the power is turned on, and off when the power switch is turned off. The ink clogging prevention function is periodically operated even when the power switch is OFF if the main power switch (P.1-3) keeps being ON (Auto maintenance function).













*1 : Ink Status

Ink status (e.g., remaining ink levels) and ink errors are indicated by icons.

Icon	Details																		
	The ink remaining levels will be indicated with the nine types of the following icons. <table border="1" style="width: 100%; text-align: center;"> <tr> <td></td> <td></td> <td></td> <td></td> <td></td> <td></td> <td></td> <td></td> <td></td> </tr> <tr> <td>Ink full</td> <td>Approx. 1/8 used</td> <td>Approx. 1/4 used</td> <td>Approx. 3/8 used</td> <td>Approx. 1/2 used</td> <td>Approx. 5/8 used</td> <td>Approx. 3/4 used</td> <td>Approx. 7/8 used</td> <td>Near end</td> </tr> </table>										Ink full	Approx. 1/8 used	Approx. 1/4 used	Approx. 3/8 used	Approx. 1/2 used	Approx. 5/8 used	Approx. 3/4 used	Approx. 7/8 used	Near end
Ink full	Approx. 1/8 used	Approx. 1/4 used	Approx. 3/8 used	Approx. 1/2 used	Approx. 5/8 used	Approx. 3/4 used	Approx. 7/8 used	Near end											
	Displayed when ink is ink end (only when 4-color ink set is used) and ink near-end. The remaining ink is little, so provide new ink.																		
	Displayed when the ink expiration date expires. Replace with new ink or use it up as soon as possible. It is possible to print.																		
	Displayed when ink end or ink error occurs. The printing cannot be performed.																		

*2 : Functions assigned to [FUNC1] to [FUNC3]

Contents of functions assigned to [FUNC1] to [FUNC3] are described below.

Icon	Contents
	Displays "MENU" for setting functions.
	Displays maintenance functions such as test print, cleaning, etc.
	Shifts to REMOTE from LOCAL and starts printing.
	Displays adjustment functions such as FEED COMP, DROP.POS correct, etc.
	Executes data clear.
	Suspends printing in REMOTE and shifts to LOCAL.
	When there are multiple items on the MENU screen or other screens, it moves to the next page.
	When there are multiple items on the MENU screen or other screens, it moves to the previous page.
	Used for completing confirmation when warning message has been displayed and so on.
	Used for turning functions OFF or cancelling them.
	Some kind of setting or function is assigned. Operate according to the description of each function.
	Switches between enable/disable when selecting multiple items, for example, when selecting target head for cleaning and so on.
	Resets the media.



- The color of icons changes according to the state of the printer.
 - When the icon is green : The printer is in REMOTE mode.
 - When the icon is dark blue : The printer is in LOCAL mode.
 - When the icon is yellow : A warning has been issued.
 - When the icon is red : An error has been issued.

Media sensor

The media sensor detects the presence of the media and the media length.

This machine has two media sensors on the platen (in the rear).

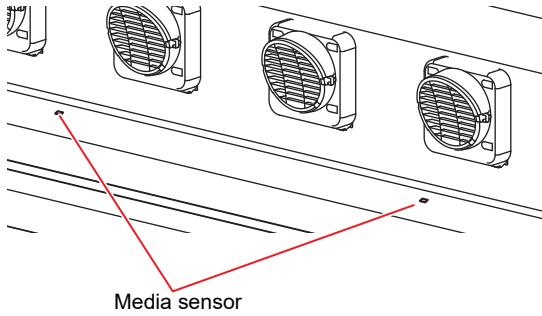

- Important!**
- When setting a media, be sure to cover the media sensors located on the rear of the platen. The media cannot be detected unless it is placed over the sensor.

Carriage

The carriage is provided with the ink heads for printing, the “LED pointer” to be used for manually setting the width of the set media (☞ P.2-26).

A lever is also provided to adjust the height of Head according to the thickness of media. (☞ P.2-27)

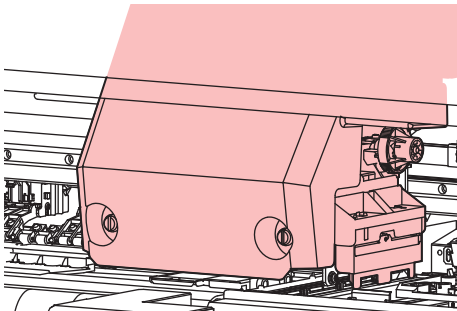

Capping station

The capping station consists of the ink caps, the wiper for cleaning the heads, etc.

The ink caps prevent the nozzles in the ink heads from drying up.

The wiper cleans the nozzles in the heads.

The wiper is consumable. If the wiper is deformed or the media is stained, replace the wiper with a new one.



- Be sure to wear the attached safety glasses in cleaning within the capping station to protect your eyes against ink. Otherwise, you may get ink in your eyes.

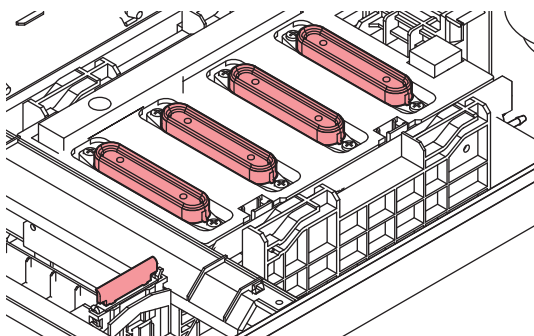

Pinch rollers and Grit rollers

This machine retains the media with the pinch rollers and grit rollers. During printing operation, the grit rollers feed the media forward.



- Keep the pinch rollers lifted up when this machine is not in use. If the pinch rollers are left lowered for an extended period of time, they can be deformed and fail to securely retain the media.

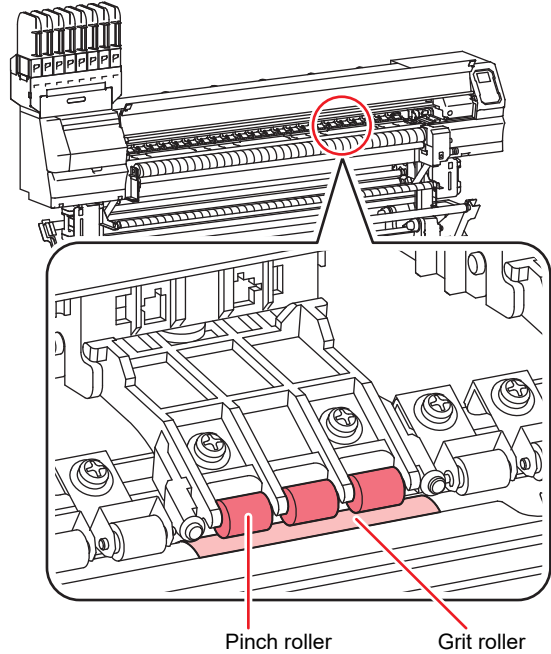

Connecting Cables

Connecting USB2.0 Interface Cable

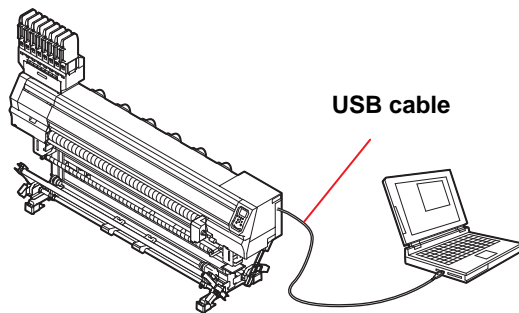

Connect the PC and this machine with the USB2.0 interface cable.



- Your RIP must be compatible with USB 2.0.
- Contact a RIP maker near your location or our office when the USB2.0 interface is not attached to the PC.

Notes on USB 2.0 Interface



- Your RIP must be compatible with USB 2.0.

● When two or more Tx300P machines are connected to one personal computer

When two or more Tx300P or Tx300P-1800 MkII machines are connected to one PC, the PC may not recognize all of the printers normally.

When a peripheral device (such as USB memory or USB HDD) to be operated in USB high-speed mode is connected to the same PC to which a Tx300P or Tx300P-1800 MkII machine is connected, the USB device may not be recognized.

If the PC has more than one USB port, reconnect the printers to another USB port and check to see if it is recognized. If the printer is not recognized even when connected to a different USB port, use commercially available USB 2.0 repeater cables.

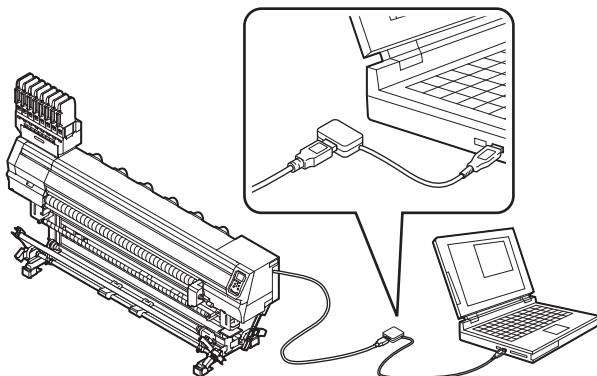

● Notes on peripheral devices in USB high speed mode

When a peripheral device (such as USB memory or USB HDD) to be operated in USB high-speed mode is connected to the same PC to which a Tx300P or Tx300P-1800 MkII machine is connected, the USB device may not be recognized.

When the printer is connected to a PC to which an external HDD is connected via USB, the printer data output speed may drop. This may cause the head unit to stop temporarily at the right or left end during printing.

● Removing USB memory

If a USB memory module is inserted in the personal computer to which a Tx300P machine is connected, click "Stop" in the "Safely Remove Hardware" window by following the instructions given there first and then remove the module.

Leaving a USB memory module inserted can cause [ERROR 10 COMMAND ERROR].

Copy the data onto the hard disk before outputting it for printing.

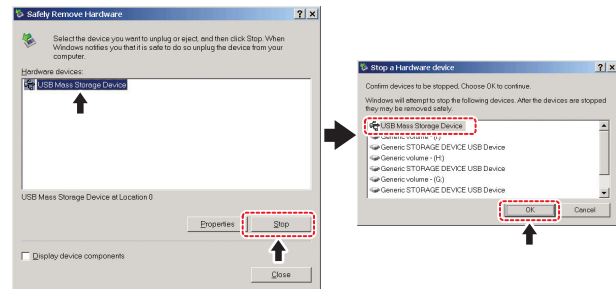

Connecting the LAN cable

When connecting LAN cable, be sure to follow the note below:



- Surely insert LAN cable until clicking noise sounds.
- Do not plug in or unplug any cable during data transferring.

Printing Via a Network

If printing via a network, you need to configure your network with the following environment.

If you configure it with an inappropriate environment, it could cause printing to stop.

- Use LAN cables that are category 6 or higher.
- Use a switching hub and PC that support 100BASE-T.



- Set the PC sending the print data and the printer to the same network.
- You cannot connect via a router.

● If connecting directly to the printer

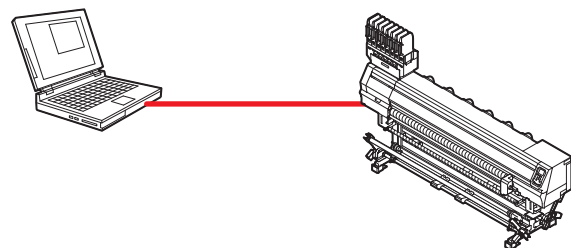

● If connecting via a switching hub

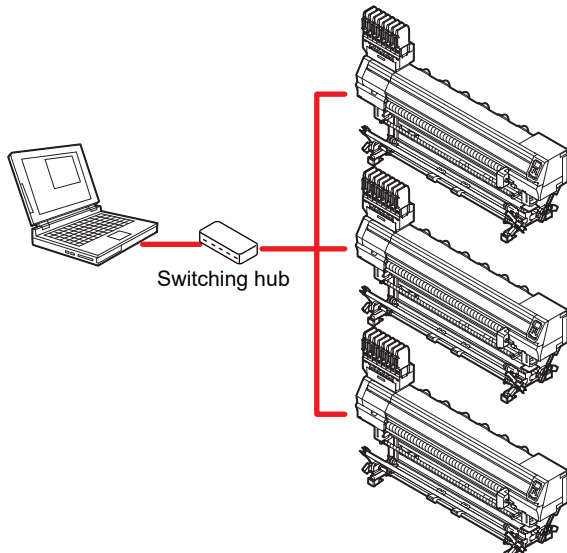

If the PC or device connected to the printer is not 1000BASE-T, you cannot perform printing. After connecting, check the following.

- (1) Check the printer screen display.
- On the local screen or the media detection screen, press the [Enter] key several times to display the information screen.
 - Check that "1000 Mbps" is displayed for the LAN status item.

- Important!**
- If "100 Mbps", "10 Mbps", or "No connect" is displayed, you cannot print using the LAN.
 - If "100 Mbps" or "10 Mbps" is displayed, you can use event mail (☞ Chapter 3 "Setting event mail function").

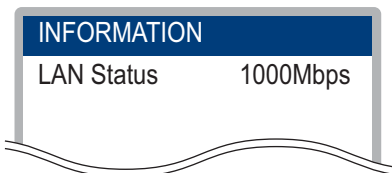

- (2) Check the green light of the LAN connector.
- After turning on the machine, the lamp for the LAN connector will light up as follows.

Color	State	Condition
Green	Lighting	Connected with 1000 BASE-T
	OFF	Connected without 1000 BASE-T
Yellow	Lighting	Link-up
	Blinking	Receiving data
	OFF	Link-down

- Important!**
- If the yellow light only lights up, or is blinking, the status is not 1000 Mbps. Check the specifications of the PC, device, and cables.

Connecting the power cable

- 1 Insert the power cable into an inlet of the machine.

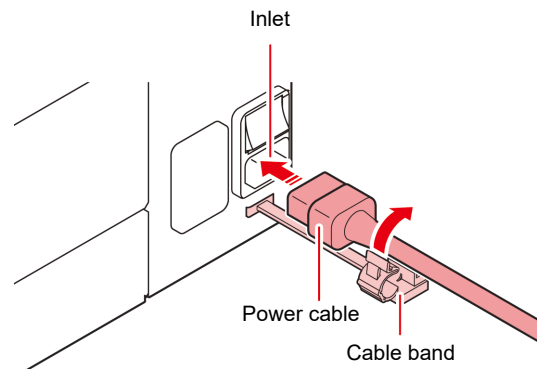

- 2 Secure a cable band.
- Secure the cable with the cable band attached to this machine.

- 3 Insert the power plug into a plug socket.

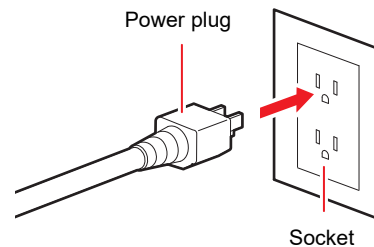

- Do not use any power cables other than the attached power cable.



- Be sure to connect the power cable to the outlet near this machine, and make sure that the power cable can be easily removed.
- Connect the power cable to the grounded outlet. Otherwise, it may result in fire or an electric shock.

Setting Ink

1 Take out the 2L ink pack.

- Take out the 2L ink pack and the IC chip from a small cardboard box.

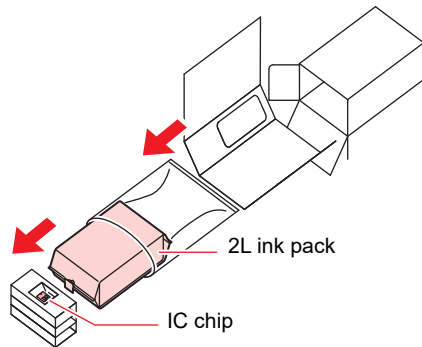

2 Mount the IC chip.

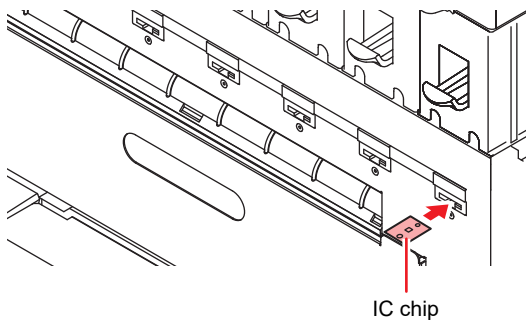

- Be careful of the IC chip direction. If it is set in the wrong direction, ink is not supplied properly.

Insert the chip facing the metal side to the left.
Do not touch the metal part while inserting. (The IC chip may be damaged by static electricity.)

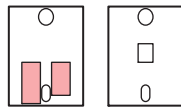

3 Put the 2L ink pack into the 2L eco case.

- Open the 2L eco case as shown on the following.

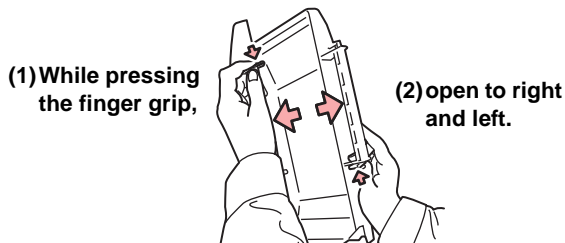

- Tear off the seal on the connector of the 2L ink pack.

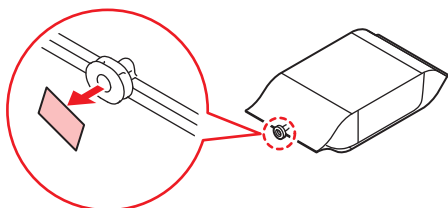

- If there is a seal remaining, when remove 2L ink pack from the pedestal base, there is a possibility that ink leaks in large quantities. Please be careful so that there is no seal remaining.



OK

No Good

- Put the 2L ink pack facing the connector down, and close the 2L eco case.

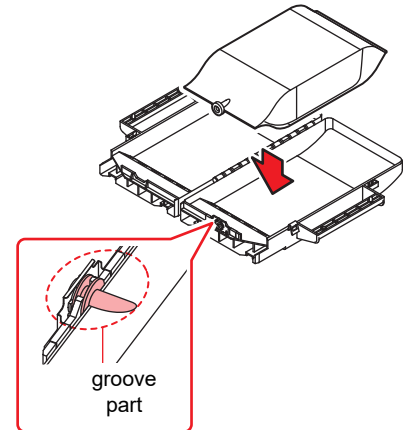

- When putting the 2L ink pack, shape the pack referring to the label in the 2L eco case. If unshaped, you may not use up the ink.
- Before closing the 2L eco case, make sure the connector of the ink pack is placed on the groove part of the 2L eco case. If it is not placed on the groove, it may not supply ink.
- Replace the 2L eco case spout rubber with a new one if it has deteriorated. (P.4-28)

4

Attach the 2L eco case to the base.

- Ink is supplied to the printer connecting to the 2L eco case.
- After 1 or 2 minutes, EMPTY lamp on the connected printer goes out.

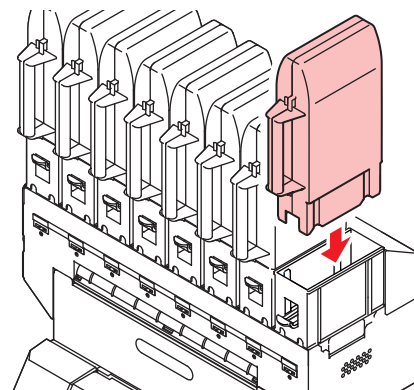

- Push the 2L eco case all the way in. If not, it may not supply ink.

1

Replacing the 2L Ink Pack

Perform as follows when [INK END] or [INK NEAR END] is displayed on the display.



- When exchanging 2L ink pack, be sure to wear the included safety glasses and gloves. Ink may splatter and get in your eyes accidentally.



- Although approximately 10 cc of ink remains in the ink pack after use, the pack is filled so that the actual amount used is two liters.

● When [INK END] is displayed

1 Push the lever of the base down, and remove the 2L eco case.

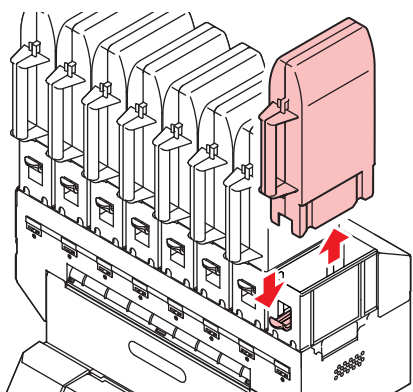

- When replacing the 2L ink pack, replace the male connector absorbent (attachment) periodically to prevent the stain in the base.
- Replace the absorbent every five to ten times of the 2L ink pack replacement. (☞ P.1-12)
- When replacing the absorbent, be sure to wear the included safety glasses and gloves.

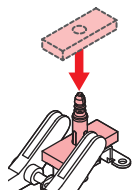

2 Remove the IC chip.

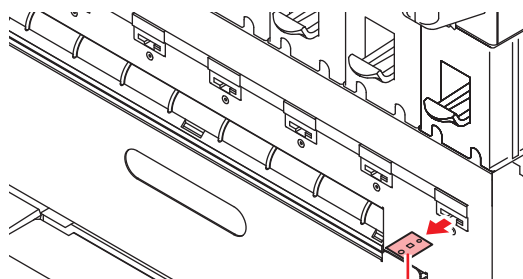

IC chip

3 Open the 2L eco case, then replace the 2L ink pack.

- Keep the IC chip removed in the step 2 with used 2L ink packs. (Not to mix with an IC chip of a new ink pack)

4 Mount the IC chip supplied with the replacement 2L ink pack.



- Be careful not to touch the metal part of the IC chip. There is the danger of damaging IC chip because of static electricity being generated.

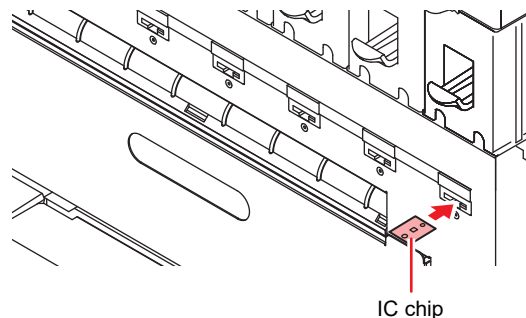

IC chip



- Request an industrial waste disposal company for disposal of used ink packs.
- If removing an ink pack before it ends, follow the procedures below. Otherwise, you cannot accurately grasp the remaining amount of ink.

- (1) Remove an ink pack from an eco case.
- (2) Wipe ink adhering to inside of the connector part of the 2L ink pack with a cotton swab etc.

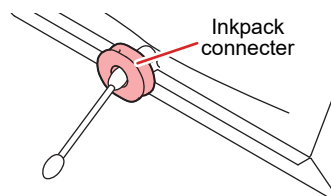

Inkpack connector

- (3) Remove the IC chip, and keep it with the ink pack.
- (4) If you use the ink pack again, set the pack, and mount the IC chip kept with the pack.

● When [INK NEAR END] is displayed

There is a little of ink left. It is recommended to replace the ink pack soon since ink may become empty in printing while printing is continuously enabled.



- During [INK NEAR END] is displayed, Auto cleaning does not operate. (☞ P.3-10)

For Ink cartridge lamps

The condition of the ink cartridges set in the machine is confirmable with lamps located under the ink cartridges.

Ink cartridge lamps

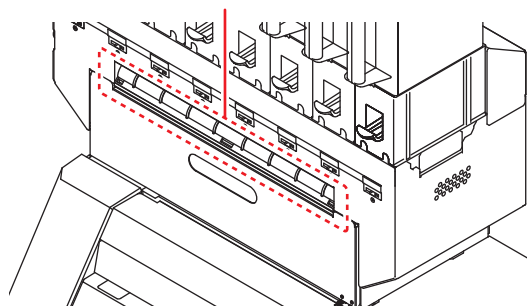

Condition of Lamp	Description
Lit to blue	No error (ink is being supplied)
OFF	No error
Lit or blinks to yellow	One of the following errors occurs. <ul style="list-style-type: none"> • Ink near-end • Expiration of a term of ink validity (one month)
Blinks to red	Expiration of a term of ink validity (two months)
Lit to red	One of the following errors occurs. <ul style="list-style-type: none"> • Ink end • No ink IC chip inserted • Other ink errors (☞ P.5-6)

Restrictions of this machine

The expiration date of ink consumption is indicated on the ink cartridge. If used beyond the expiration date of ink consumption, ink ejection failure and color change may occur. You can print after the expiration date, but we recommend that you replace it with new ink or use it up as soon as possible.

Ex.) When the expiration date of ink consumption is April.
 May : Replace with new ink or use up as soon as possible. It is possible to print.
 June: Replace with new ink or use up as soon as possible. It is possible to print.
 July : Cannot print.



- A message will be displayed on the display to let you know.

About Name

In this manual, the 2L ink pack, 2L eco case and ink IC chip are collectively described under the name of "ink cartridge".

Caution in handling of ink packs



- Use genuine ink packs for this machine. This machine functions by recognizing the genuine ink packs. In case of troubles caused by modified ink packs or the like, it shall be out of the warranty even within the warranty period.
- If the ink pack is moved from a cold place to a warm place, leave it in the room temperature for three hours or more before using it.
- Be sure to thoroughly consume the ink in the ink pack, once it is opened, within one month. If an extended period of time has passed away after opening the cartridge tank, printing quality would be poor.
- Make sure to store ink packs in a cool and dark place.
- Store ink packs and waste ink tank in a place that is out of the reach of children.
- Request an industrial waste processor for processing of empty ink packs.
- **Precautions for new installation and replacement of new spout rubber**
 - Moisten the surface of the spout rubber with maintenance solution sufficiently before inserting. Inserting the rubber into the eco-case without moistening may damage the rubber.



- In that case, use a maintenance solution that is suitable for the ink type.

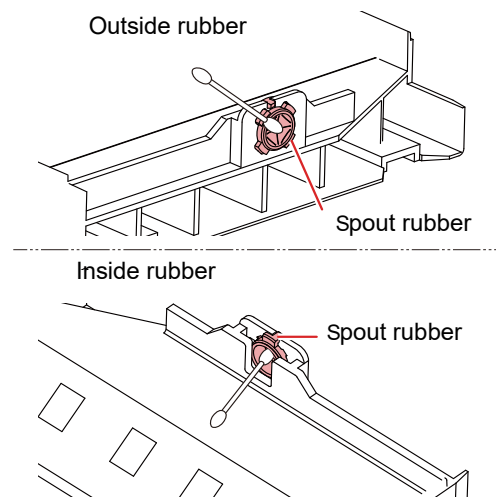

- **Precautions for using a partially used ink pack**
 - Wipe the ink off the inside of the ink pack connectors with cotton swab. Inserting the ink pack while the ink remains inside the connector part may cause ink leaking when the ink pack is used again.



- Do not insert the cotton swab too deeply. Ink may leak out of the ink pack and become unstopable.

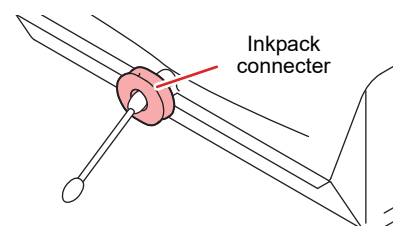



- **Precautions for setting the eco-case in the main unit**
 - Confirm that the eco-case is fully inserted. Check whether there is a gap between the MBIS Base and the eco-case. If there is a gap, insert the eco-case again.

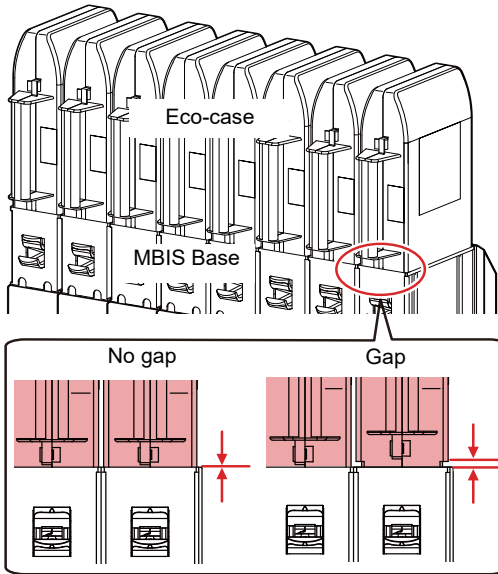

- **Method of agitating the ink pack in the eco-case**
 - When agitating the ink pack after removing (Recommended method)
 - Wipe off the ink from the connector part of the ink pack and the inside of the spout rubber before resetting.
 - Cover the connector part of the ink pack with a paper towel (Wiping Rags, etc.) before agitating.
 - When agitating the ink pack together with the eco-case
 - Spout rubber with a paper towel (Wiping Rags, etc.) before agitating.

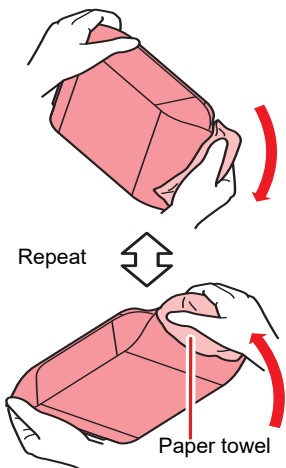

- Do not shake ink packs violently. This may result in ink leakage from the ink packs.
- Never refill the ink packs with ink. This may result in troubles. MIMAKI will not bear any responsibility for any damage caused by the use of the ink packs refilled with ink.



- Do not disassemble the ink packs.

Turning the Power ON/OFF

Turning the Power ON

This machine is provided with the following two power switches:

Main power switch :

It is located on the side of this machine. Keep this switch ON all the time.

[END/POWER] key :

Normally, use this key to turn the power ON/OFF. The nozzle clogging prevention function periodically operates even with the [END/POWER] key turned OFF when the main power switch is turned ON.

1 Turn the main power switch ON.

- Set the main power switch located on the side of this machine to the "I" side.

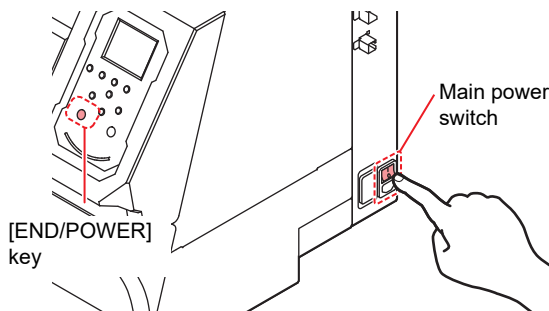

- The firmware version is displayed when the power is turned ON, and then the machine performs its initial operation.

2 Turn the power on, by pressing the [END/POWER] key.

- The machine enters LOCAL.

3 Turn ON the power of the connected PC.

- Important!**
- Turn the power ON after the front cover and maintenance cover are closed.
 - The head nozzle may result in nozzle clogging if the main power switch is left OFF for a long time.

Turning the Power OFF

When having ended the operation of the machine, turn the power OFF by pressing the power switch located on the front side.

Check the following items when turning the power OFF.

- If the machine is receiving data from the PC or if there is any data that has not been output yet
- If the head has returned to the capping station
- If any error has occurred
(☞ P.5-7 "Error messages")

1 Turn OFF the power of the connected PC.

2 Turn the power off, by giving the [END/POWER] key a long press.

- Do not turn OFF the main power switch located on the side of the machine.
- To use this machine again, press the [END/POWER] key .

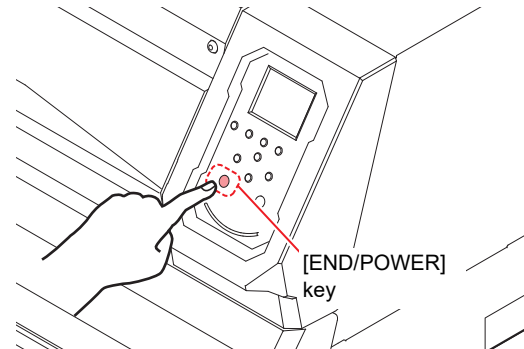

Cautions about Turning the Power OFF

● Do not turn the main power switch OFF.

When the main power switch is ON, the power periodically turns ON and the nozzle clogging prevention function (flushing function) operates. When the main power switch has been turned OFF, the auto maintenance functions, such as flushing, do not operate, and this may cause nozzle clogging.

● Keep the front cover and the maintenance cover closed.

If the cover is opened, the auto maintenance function such as the flushing function does not work.

● Turn the power OFF after having checked the position of the head.

If the power is turned OFF in a state where the head has not returned to the capping station, the ink head dries, which may cause nozzle clogging.

In this case, turn the power ON again and check that the head has returned to the capping station, and then turn the power OFF.

● Do not turn the power OFF during printing.

The head may not return to the capping station.

● After having turned the power switch OFF by pressing [END/POWER] key, turn the main power switch OFF.

When turning the main power switch off for moving the machine or for solving the error or the like, press the [END/POWER] key a long time on the front of the machine, check the display is turned off on the operation panel, and then turn the main power switch of

Media

Usable media sizes and notes for handling are described.

Usable sizes of media

Model		Tx300P-1800
Type of Recommended media	Pre-treated polyester material	
Maximum width	1,920 mm (75.6 in)	
Minimum width	210 mm (8.3 in)	
Maximum printing width	1,920 mm (75.6 in)	
Roll media	Thickness	1.0 mm or less (0.039 in or less)
	Roll outside diameter	Φ 250 mm or less (Φ 9.8 in or less)
	Roll weight	40 kg or less (88.2 lb or less)
	Roll inside diameter	2 or 3 inches
	Side printed	Regardless of faces in and out
	Roll end treatment	The roll end is gently fixed to the core with weak-adhesive tape or weak glue for easy removal.

Model		Tx300P-1800 MkII		
Type of Recommended media	Pre-treated polyester material	Transfer paper (Sb411+TP400 Ink 4 + 4-colors ink set) / (Sb411+Sb420 Ink 4 + 4-colors ink set)		
Maximum width	1,920 mm (75.6 in)	1,950 mm (76.8 in)		
Minimum width	210 mm (8.3 in)	210 mm (8.3 in)		
Maximum printing width	1,920 mm (75.6 in)	1,940 mm (76.4 in)		
Roll media	Thickness	1.0 mm or less (0.039 in or less)		
	Roll outside diameter	Φ 250 mm or less (Φ 9.8 in or less)		
	Roll weight	40 kg or less (88.2 lb or less)		
	Roll inside diameter	2 or 3 inches	2 or 3 inches	
	Side printed	Regardless of faces in and out	Side facing outward	
	Roll end treatment	The roll end is gently fixed to the core with weak-adhesive tape or weak glue for easy removal.		

Switching between cloth media and paper media (transfer paper) (Tx300P-1800 MkII only)

The Tx300P-1800 MkII is capable of printing on both cloth media and paper media (transfer paper).

Switching between the different media requires changing the platen and altering the print settings. The main unit should be prepared and the settings altered as described in this manual.

Be sure to adhere to the warnings and precautions described.

Caution in handling of media

Pay attention to the followings for handling of media.

● Media



- When using a media other than the following, be sure to perform test printing to confirm the plot result and then determine whether it can be used or not.
- Do not leave pre-treated fabric media set. Medicant of pre-treatment agent may promote rust of the grit roller.



- Use media recommended by MIMAKI to ensure reliable, high-quality printing.
- When setting the fabric used, be sure to adjust the head height. Otherwise, the fabric and/or the head can be damaged.
- If preventing treatment for fray on right and left edges and tenter are thick against the fabric thickness, adjust the head height and stainless plate height of the fabric holder depending on the thickness of the right and left edges of the fabric.
- If using fabric with thick right and left edges, as take-up slippage may easily occur because right and left edges of the roll rise at take-up. If take-up slippage occurred, fabric tends to skew and it may cause troubles such as contact with the head nozzle surface.
- Do not use a fabric with high expansion and contraction due to ink adhesion or resilient fabric. If such a fabric is used, it may cause the trouble of contact with the nozzle surface or the misaligned printing.
- When using a fabric with curling, be sure to remove the curling before using. Strong curling may effect on the quality of printing or may hit the head nozzle surface and may cause discharging defect.
- Store fabric in a bag. Wiping off dust, waste paper and flocks accumulated on a fabric will adversely affect the fabric due to static electricity.
- When you use fabric media that will easily generate static for printing, use the attached neutralization fabric. In addition, raise the humidity of the usage environment by using a humidifier etc.

● Transfer paper



- **Use media recommended by MIMAKI to ensure reliable, high-quality printing.**
Use media recommended by MIMAKI to ensure reliable, high-quality printing.
- **Pay attention to the expansion and contraction of the media.**
Do not use media immediately after unpacking. The media can be affected by the room temperature and humidity, and thus it may expand and contract. The media have to be left in the atmosphere in which they are to be used for 30 minutes or more after unpacked.
- **Do not use curled media.**
This may result in paper jamming. If a regular-sized coated sheet of media is rolled and stored, the coated side has to face outside.
- **Be careful to dusts on the edge face of the media.**
Some rolls have dusts contained in the package gathered on the edge surface of the roll. If you use as it is, the drawing quality may be degraded due to nozzle missing or ink drops. Be sure to set the roll after removing dusts adhering on the edge face of the roll.

Limited media

With the following media, correction from the plotter is difficult.



When using any of the following media, perform test printing to determine whether it can be used or not.

- High stretch fabric (Stretch materials, vertically extendable knit, etc.)
- Materials which become largely extendable when getting wet by printing.
- Materials with large width variations.
- Materials which present partial wrinkles or slacks when being spread on a flat surface or materials which are totally curved.
- Materials with large take-up shift at the ends of media when rolled.
- Roll media with a paper tube whose strength is insufficient and which bends when attached to a feeding unit.

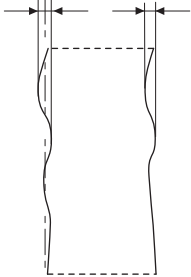

- Even when using media other than described above, be sure to print by optional test data. After checking the printing result, judge whether it can be used or not.

Fabric conditions which enable to print

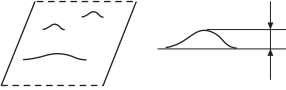
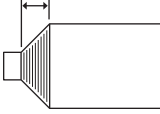
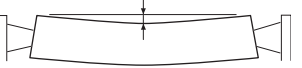
Items	Condition	Remarks
Width variation	less than ± 5 mm / one side edge	
Curve when expanded	One-direction curve not allowed	
Slack height when expanded on a flat surface	2 mm or less	
Displacement of roll edge	± 15 mm, Cloth (width of 500 mm and less) is ± 2 mm.	
Inner diameter of roll	2 to 3 inches	
Fabric core strength	Roll bend of 5 mm or less when set.	
Fixation with fabric core	Fix with the tape three point or more or weak adhesion.	
Roll outer diameter	ϕ 250 mm or less	
Roll weight	40 kg or less	
Print side	Not specified	
Fabric wrinkle	Not allowed	

Menu mode

This machine has 4 modes. Each menu mode is described below.

NOT-READY mode

This is the mode in which the media has not been detected yet.

LOCAL mode

Local mode is the mode for the drawing preparation state.

All the keys are effective.

The machine can receive data from the computer. However, it does not perform printing.

Screen display in Local mode

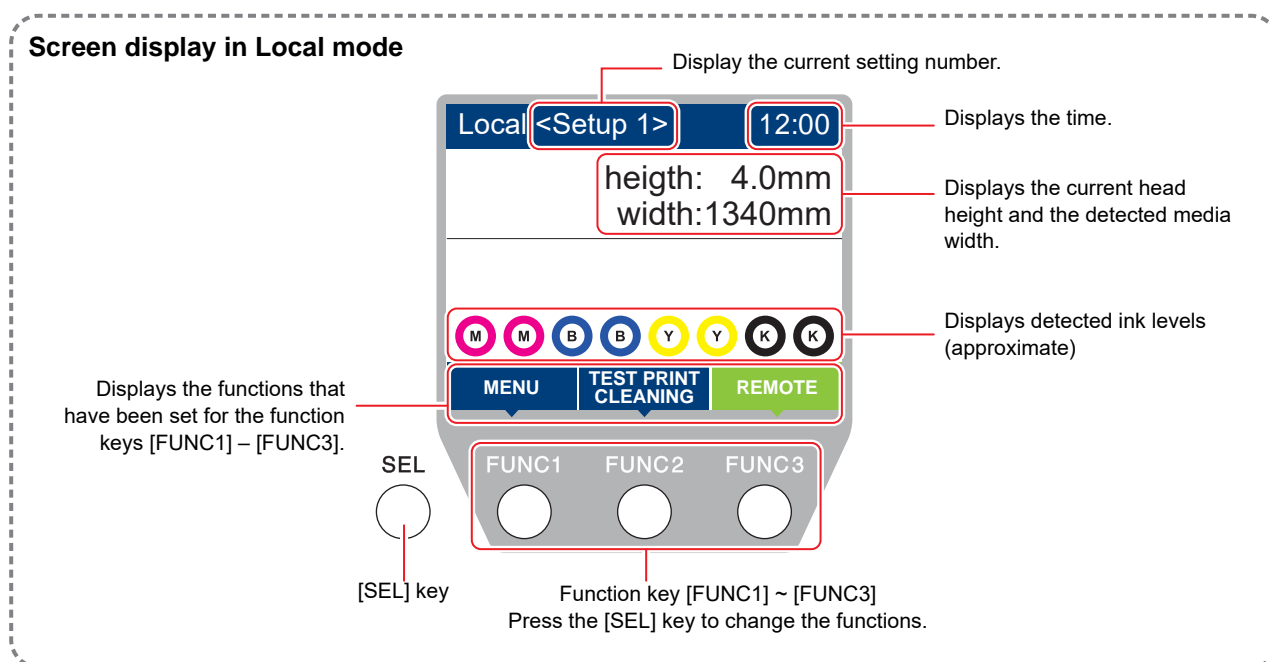

This mode permits the following operations:

- Pressing the JOG keys to set up a drawing origin and drawing area.
- Pressing the [ENTER] key to check the remaining amount of ink, the description of the cartridge error, the model name, the firmware version, and so on.

MENU mode

To set MENU mode, press the [FUNC1] key when this machine is in LOCAL mode.

In this mode, each function can be set.

REMOTE mode

This machine prints the data it receives.

Chapter 2

Basic Operations



This chapter

describes procedures and setting methods for ink and media preparation, and printing.

Workflow	2-2	Media information setup	2-26
Preparing the main unit	2-4	Print adjustment	2-28
Platen change (Tx300P-1800 MkII only)	2-4	Changing the printing origin	2-28
Changing with the cloth media platen	2-4	Test Printing	2-28
Attaching the paper(transfer paper) platen.	2-5	Head Cleaning	2-29
Spacer installation (cloth media)	2-7	Feed settings	2-30
Turning on the main power supply	2-8	If the Positions of Dots Shift... ..	2-30
Adjusting the Head Height	2-8	Adjustment to Refine Finished Printing	2-32
Feeding/ Take-up device	2-9	Flow of media feeding correction	2-32
Media Edge Guide	2-10	Printing Data	2-33
How to adjust the weight of feeding/ take-up tension-bar (cloth media)	2-11	Starting a Printing Operation	2-33
Setting the torque limiter (cloth media)	2-14	Stopping a Printing Operation	2-33
Setting a Media	2-16	Deleting Received Data (Data Clear)	2-33
Setting up the roll media (cloth media)	2-16	Behavior after printing has been completed	2-33
Setting up the roll media (transfer paper) (Tx300P-1800 MkII only)	2-22	Media removal	2-34
Setting leaf media (cloth media)	2-24	Removing the roll media	2-34
Setting leaf media (Transfer Paper) (Tx300P-1800 MkII only)	2-25		

Workflow

1 Preparing the main unit

Prepare the main unit before printing.
The platen on the Tx300P-1800 MkII must be changed depending on whether cloth media or paper media (transfer paper) is used.

2 Setting a Media

Set the media to be printed into the main unit.

3 Print adjustment

Adjust the main unit and media before printing.

4 Printing Data

Once preparations are complete, start printing.

5 Media removal

Remove the printed media once printing is complete.

Print Preparation Workflow

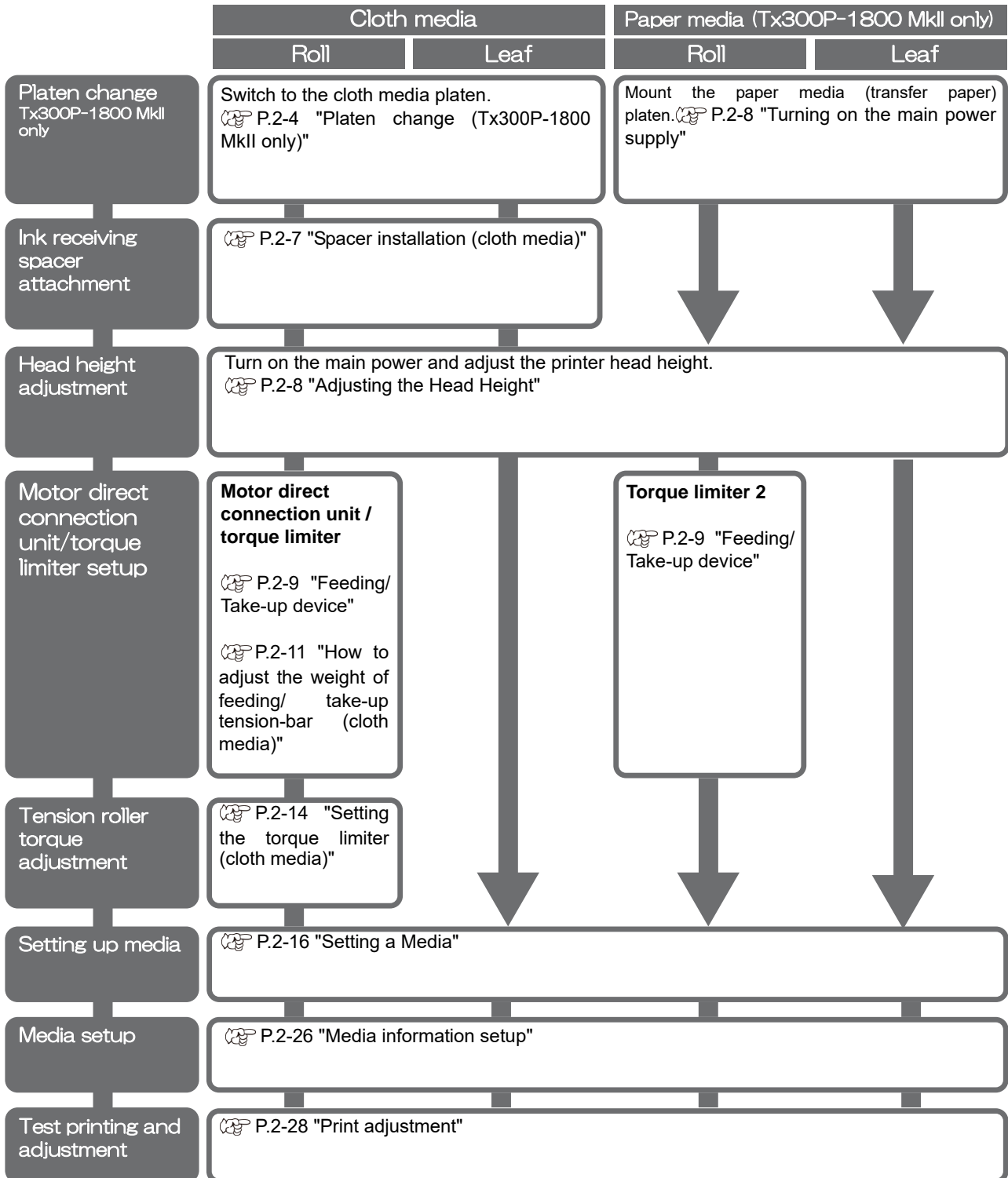

Preparing the main unit

Prepare the main unit according to the media type and setting method used.

Platen change (Tx300P-1800 MkII only)

The Tx300P-1800 MkII is capable of printing on both cloth media and paper media (transfer paper). The corresponding platens must be changed when using different media.

Tx300P-1800 MkII platen

Removable platen for paper (for transfer paper)

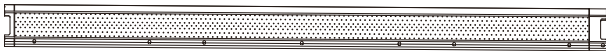

Platen for paper storage

A platen holder is provided below the front of the main unit. (☞ P.1-5)

The platen not currently being used should be stored here.

● Platen holder

Store the platen for paper.

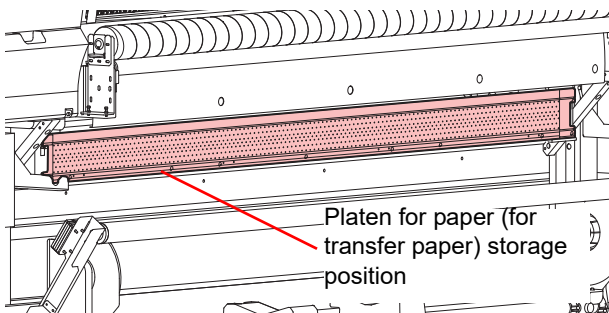

Before storing the platen for paper, secure using the platen holder hooks.

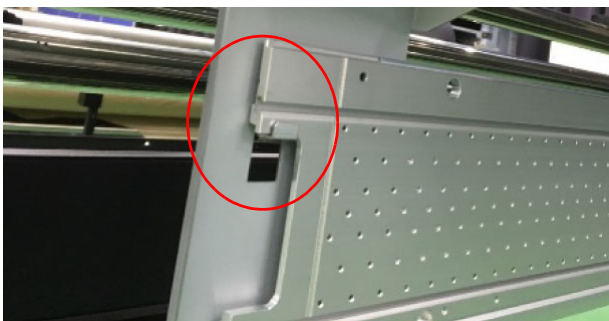

- Check to confirm that the removed platen is securely mounted on the hooks and stands. There is a risk of the platen for paper falling if it is not securely mounted.

Carrying the platen for paper



- The platen for paper is made of thin metal sheet. Take great care to avoid cutting your fingers during handling.
- Take care to avoid hitting nearby people or objects when carrying the platen.

Hold using both hands with the pins and magnets facing downward.

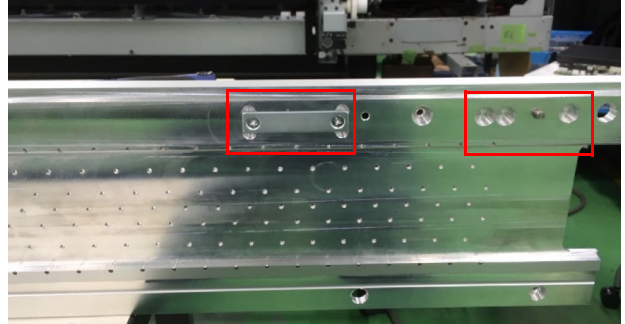

Grasp the platen for paper near the center.

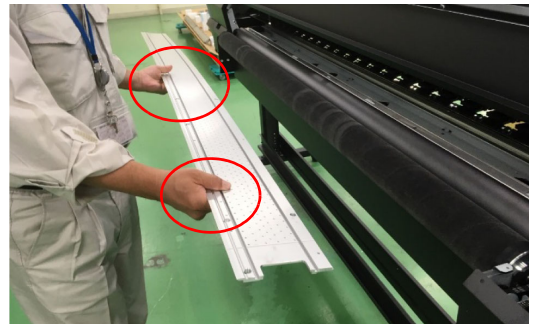

Changing with the cloth media platen

If the platen for paper (for transfer paper) is mounted, change it out for the cloth media platen, as follows:



- Be sure to turn off the main power supply before changing the platen.



- If media is in place, remove the media before changing the platen. (☞ 「P.2-34 Media removal」)



- If the platen is dirty after printing, clean before removing. (☞ P.4-4 Cleaning the Platen)

1

Open the front cover.

2

Remove the two media presses.

- Slide into the maintenance space to remove.

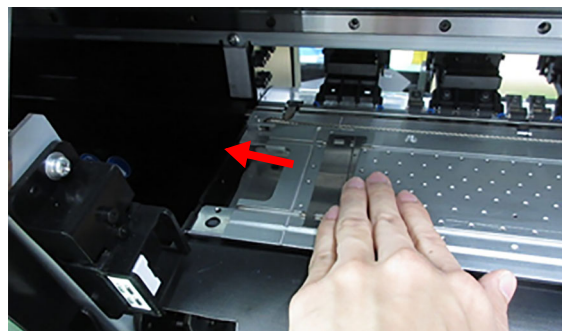

3 Lift up the platen for paper.

- The platen for paper is held in place securely by magnets. Lift up as described below.
- Insert the provided ink receiving spacers into the locations indicated by red arrows between the platen for paper and the main unit.
 - Push up the platen for paper using the ink-receiving spacers, then lift up.

Platen for paper

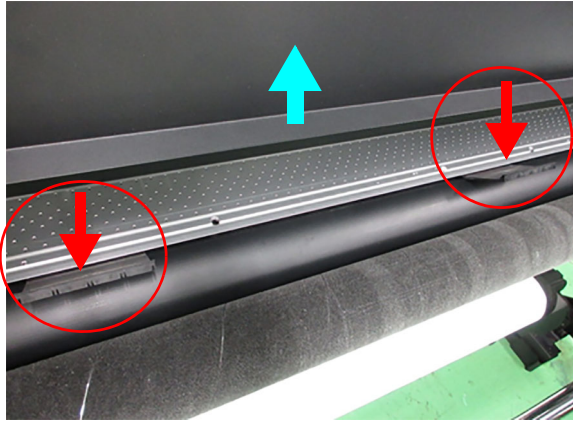
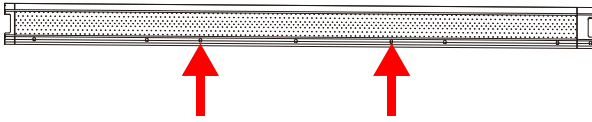

- These are held by magnets. Take care that they do not spring up when removing.
- Do not force the ink receiving spacers when inserting them. Otherwise there is a risk of damaging parts.

4 Pull the raised platen for paper toward you and remove from the rear platen.

- Store the removed platen in the platen holder underneath.



- The parts removed will be needed when using the platen for paper again. Keep in a safe place.

5 Attach the fabric retainers.

- Engage into the ink guard F and rear platen. The fabric retainers are located on the left and right.

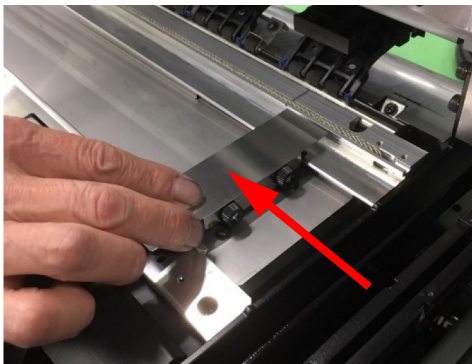

Attaching the paper(transfer paper) platen.



- Be sure to turn off the main power supply before changing the platen.
- If the platen is dirty after printing, clean before removing. (P.4-4 Cleaning the Platen)
- Take care not to get ink on your clothing or hands.



- If media is in place, remove it before changing the platen. (P.2-34 Media removal)

1 Open the front cover.

2 Remove the fabric retainers.

- Remove from the station side (where the carriage is located).
- Remove the ink receiving spacers if they are fitted. (P.2-7 Attaching/removing ink receiving spacer)

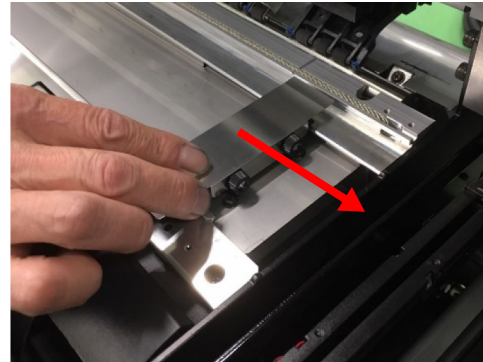

3 Remove the platen for paper from the platen holder.

4 Align the end of the platen with the right edge of the rear platen, then push in.



- Make sure paper scraps and other debris do not become trapped when pushing in the platen.
- Remove any paper scraps or other debris before proceeding.

5 Place the front edge of the paper platen on the platen frame.

- Align the pins on the edge of the platen for paper and engage securely in the channel on the platen frame.

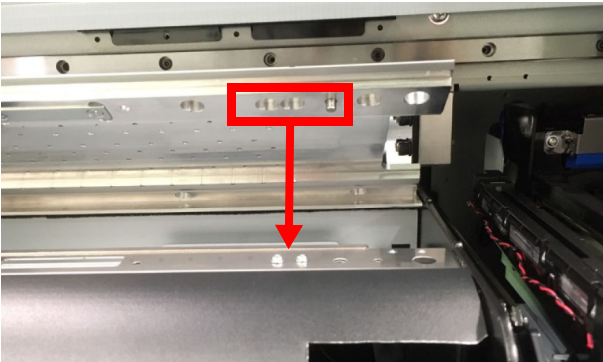

- Check to confirm that the platen for paper is securely mounted and not raised.



- The magnets on the platen for paper are very strong. Be careful to avoid trapping your fingers when attaching the platen.

OK : No gap between the platen and platen frame

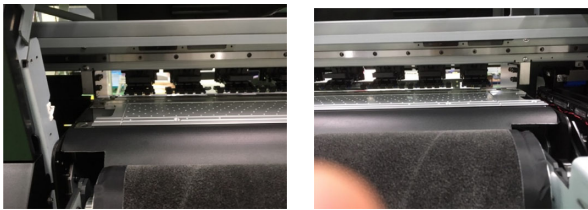

Not Good : Gap between platen and platen frame

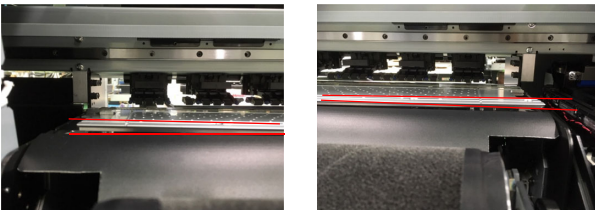

6 Attach the media presses (left and right) from the maintenance cover sides.

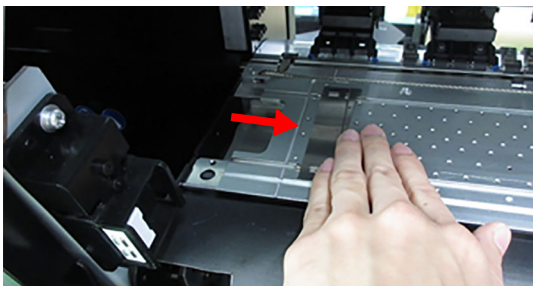

Spacer installation (cloth media)

Depending on the media you use and the printing method, set the spacer type (attached two types).

● About each spacer

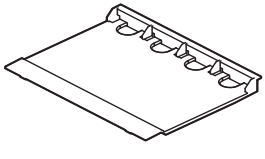
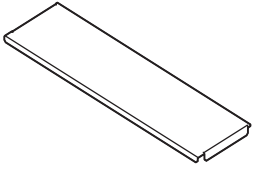
Ink receiving spacer	Adjusting spacer (Tx300P-1800 Only)
	

● When printing on the fabric (when over print is not performed)

Use ink receiving spacer.

● When printing on the fabric (when over print is performed)

Use the ink receiving spacer.

● When you perform Drop Position correct

Use the adjusting spacer. (☞ P.2-30)



- For drop position correction with the Tx300P-1800 MKII, use the platen for paper. (☞ P.2-5 Attaching the paper(transfer paper) platen.)

When you perform over printing

When you perform over printing, set the fabric media after performing the work below:

For "Setting the Media Detection" in machine setup, set "MANUAL" for the detection method (☞ P.3-16), and set the media width by referring to P.2-26 "Setting of the manual media width setting".



Reference for attaching ink receiving spacer / fabric edge spacer

- Arrange ink receiving spacers so that they cover an area wider than the width of the image to be printed.
- Adjust the number of spacers so that they are apart from right and left edges of the image by 10 mm and more.
- To perform over printing, arrange ink receiving spacers so that they cover an area wider than the media width.

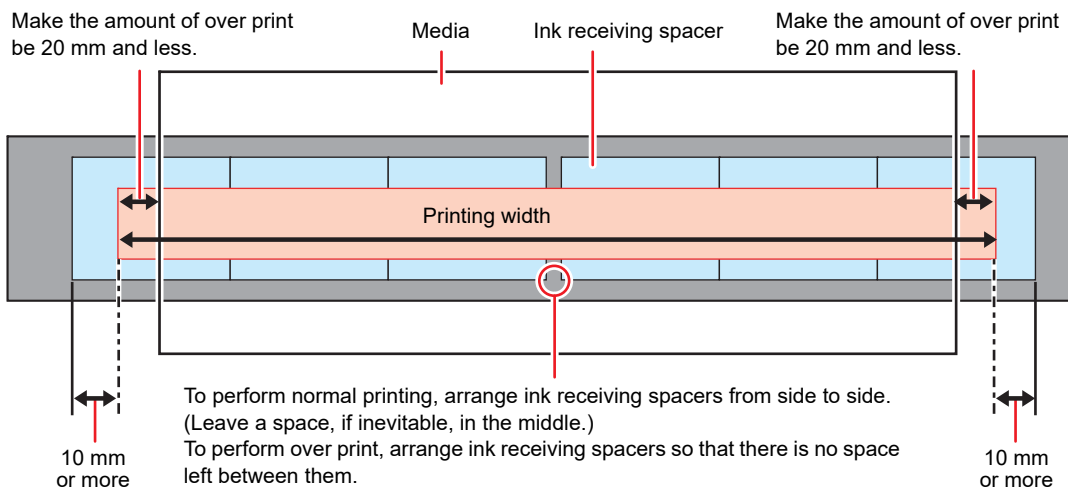

Important!

- When you performed over printing, at detecting the media after setting it, the media width input screen is displayed. At this time, input the set media width, and press the [ENTER].

Attaching/removing ink receiving spacer

When printing, to prevent media from staining due to ink mist, be sure to set the ink receiving spacer.

1 Move the fabric retainer to the left and the right.

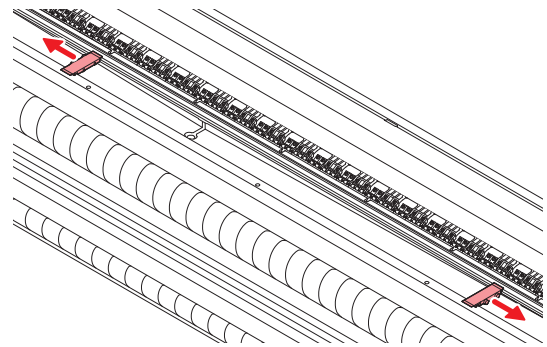

2 Attach the ink receiving spacer.

- The size of the ink receiving spacer is W: 100 mm. Depending on the width of the image to be printed, adjust the number of ink receiving spacers to attach.

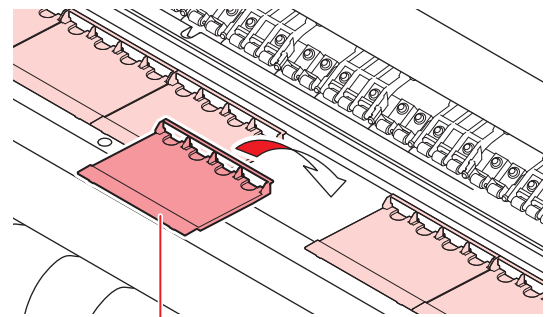

Turning on the main power supply

Once preparations up to inserting the spacers have been completed, turn on the main power supply. For more information on how to turn on the power, (P.1-15 Turning the Power ON)

Media selection (Tx300P-1800 MkII only)

The MEDIA SELECT screen appears on the display when the main power is turned on. Select according to the media being used for printing.

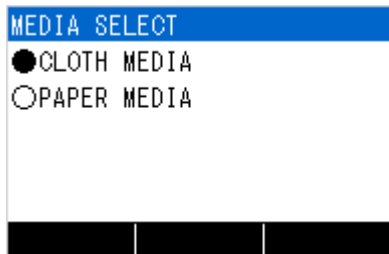

Adjusting the Head Height

Set the head gap (height from the media to the nozzle plane of the heads).

When the carriage is to move above the platen for printing or maintenance, it moves while keeping the head gap at the preset value.

The upper limit of the head gap varies with media thickness.

Available setting values: [2.0 mm to 7.0 mm] (in units of 0.1 mm)

1 Press **FUNC1 (MENU)** (twice) → **ENTER** key in LOCAL.

- MACHINE SETUP MENU will be displayed.

2 Press **▲ ▼** to select "HEAD HEIGHT", and press the **ENTER** key.

- Move the carriage to the platen.

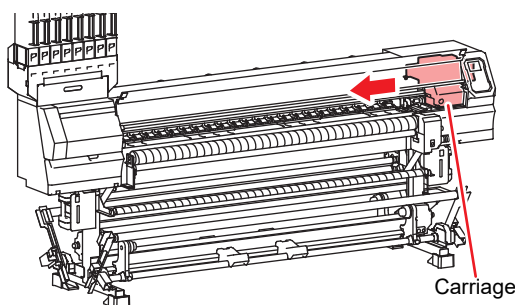

3 Loosen the height-adjusting screw in front, and press the **ENTER** key.

- Loosen the screws, rotating each by one turn of a standard screwdriver.

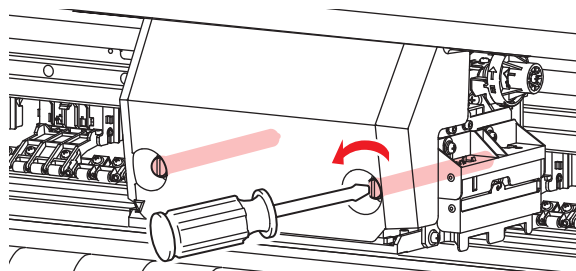

4 Adjust the height-adjusting handle according to the media.

- Rotate **2** while pressing **1**.
- Look at the display and adjust to an appropriate value.

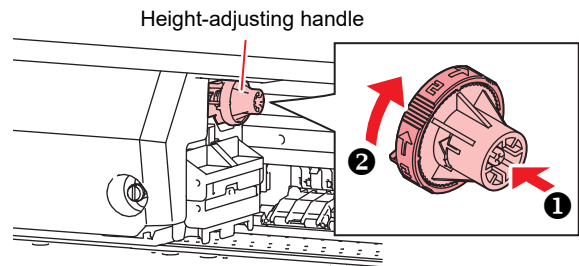

- Important!**
- When printing on fabric, pay attention to the height of the head. When setting the head height to 3 mm or less, make sure that the head does not hit the jam sensor before using it.

5 Fix the carriage.

- Fasten the screw securely.

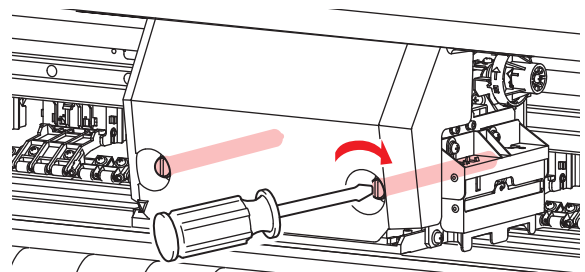

6 Press the **ENTER** key.

- The carriage automatically returns to the station.

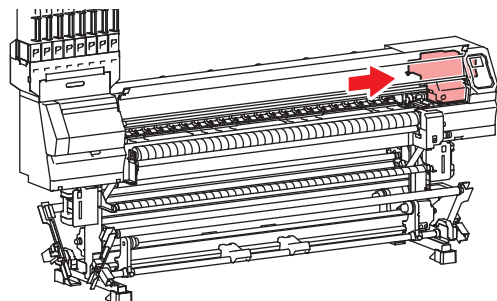

7 Press the **END/POWER** key several times to end the setting.

Feeding/ Take-up device

With the switch of the feeding/ take-up device, select the take-up direction of the media or others.

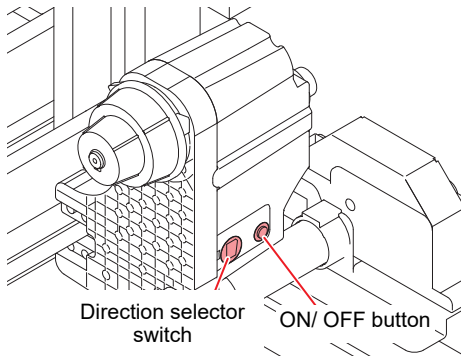

Feeding unit	Direction selector switch	UP (REVERSE)	<ul style="list-style-type: none"> To feed face-in media by using tension bar. Applying tension on face-out media using small take-up unit.
		DOWN (FORWARD)	<ul style="list-style-type: none"> To take up face-out media by using tension bar. Applying tension on face-in media using small take-up unit.
	ON/OFF button		Turns the winding motion on/off. (When you press the button and operate the feeding device, the device keeps taking up the media until you press the button again. *1)

*1. You can also change the setting so that the feeding operation only lasts while the ON/OFF button is being pressed. For details, refer to "Feeding/ Take-up device" (P.2-9) in machine setups.
Note that the ON/OFF button for feeding device is also located near the clamp lever in the back of the machine. Use the button that is easier to use when setting media.

Take-up unit	Direction selector switch	UP (REVERSE)	The take-up device winds the media with the printed side facing in.
		DOWN (FORWARD)	The take-up device winds the media with the printed side facing out.
	ON/OFF button		Turns the winding motion on/off. (When you press the button and operate the take-up device, the device keeps taking up the media until you press the button again. *1)

*1. You can also change the setting so that the taking-up operation only lasts while the ON/OFF button is being pressed. For details, refer to "Feeding/ Take-up device" (P.2-9) in machine setups.

Replacing the direct-connection unit

The feeding and take-up device direct-connection unit is also included when you purchase the product. If you do not use feeding/take-up tension bar, replace direct-connection unit with torque limiter.

The feeding and take-up torque can be adjusted with the torque limiter.

(The torque limiter is set to "Medium" at delivery.)

Important! • When using paper media (transfer paper), use torque limiter 2.(Tx300P-1800 MkII only)

● Torque limiter attachment

To wind the media without using tension bar, you must replace direct-connection unit with torque limiter.

1 Remove the direct-connection unit.

- Remove the thumbscrew, and then remove the direct-connection unit.

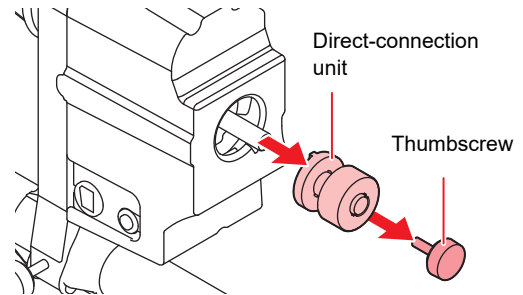

2 Attach the Torque limiter.

- (1) Insert so that the projection of the Torque limiter match the groove of the feeding/ take-up device.

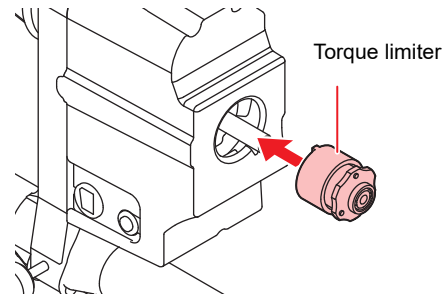

- (2) As shown in the illustration, attach it so that the tip of the shaft of the feeding/ take-up device matches the surface of the Torque limiter.

Important!

- As shown in the figure, attach it so that the tip of the shaft of the take-up device matches the surface of the torque limiter. If the tip of the shaft and the surface of the torque limiter does not match, the take-up of the media will not run well.

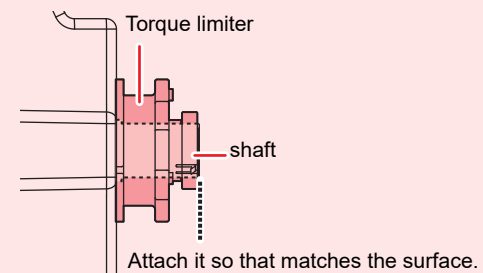

- (3) Use the thumb screw to fix the Torque limiter

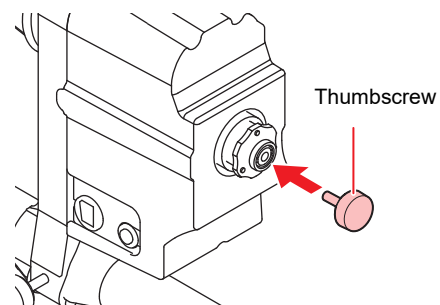

● **Torque limiter adjustment**

Clockwise turn :

Increases torque (a heavy and thicker media such as tarpaulin or the like)

Counterclockwise turn :

Decreases torque (For light media)

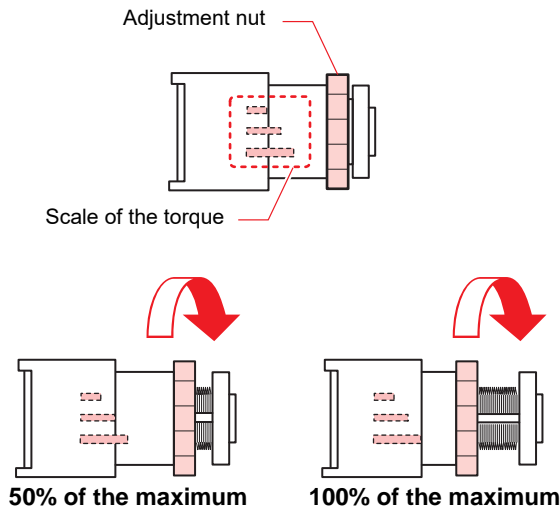

Important!

- **When the torque limiter is adjusted too weak ;**
The media can not be taken up firmly.
- **When the torque limiter is adjusted too strong ;**
The slack may occur depending on the media and cause influence on the image quality.
- When using the tension bar, adjust the torque limiter at about 75 to 100% of the maximum torque.
When adjusting the torque limiter, use the torque adjustment handle supplied.

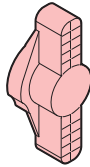

- When the tension is set to be high, depending on the type of media, the edge of the roll media may shift in the lateral direction. In such a case, use the media edge guide.



- There are the following two methods for taking up the media on printer:
(1) Only use the take-up device to take up the media
(2) Use the tension bar to take up the media
 - Tension bar is located on both the feeding side and the take-up side. You can select between Use/Do not use for feeding tension bar and take-up tension bar separately. (P.3-14)

● **Motor direct connection unit attachment**

Also refer to the torque limiter replacement procedures when reattaching from the torque limiter to the motor direct connection unit.



- Insert so that the projection of the motor direct-connection unit match the groove of the feeding/ take-up device when attaching the motor direct-connection unit.

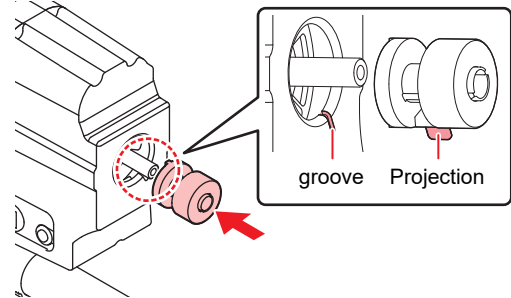

Media Edge Guide

The media edge of the taken up roll media may shift laterally. In such cases, use the Media Edge Guide to prevent the lateral shifting.



- When using the media edge guide, the roll media diameter is limited.
- Use within dia.200mm to 120mm. (Varies depending on the position of the edge guide)

1 Adjust and fix the position of the Media Edge Guide.

- The set position of the Media Edge Guide defers depending on the diameter of the roll media of before printing. Refer to the table below for adjustment.

Roll media diameter	Media Edge Guide set position
~Φ 120mm	1mm
~Φ 170mm	3mm
~Φ 200mm	5mm

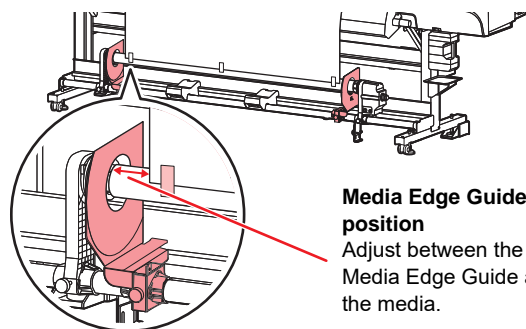

Media Edge Guide set position
Adjust between the Media Edge Guide and the media.

How to adjust the weight of feeding/ take-up tension-bar (cloth media)

There are various types of media of different size of string and different texture. Further, even with the same media, their stretching characteristics may vary due to differences in their pre-treatment process. For such a wide variety of media, in order to print to the relevant type of media by applying appropriate tension for it, you must adjust the weight of feeding/ take-up tension bar and the mounting position of the folding bar by using counter weight and weight adjustment spring.

● About counter weight and weight adjustment spring

Depending on the attaching position of the counter weight and the weight adjustment spring, you can adjust the tension bar weight.

You can attach the counter weight up to 12 each for right and left (Large: 2, Small: 10).

Phenomenon			Countermeasure
Media front surface at setting	At printing	Print result	
The print surface tightens.	Stable printing can be performed.	Surface waviness or ruck on the media is hardly found.	The tension is suited for the media. It is not required to adjust the counter weight.
Surface waviness has occurs on the media and the printing surface comes down.	The media flops at printing.	As the print surface comes down, printing cannot be performed with the proper head height. Therefore, the printing quality deteriorates.	The tension applied on the media is too weak. Make the tension bar heavier.
As the media is pulled too much, ruck partially occurs between the pinch rollers etc.	The tension bar bends and ruck occurs on the media or the media skews.	Ruck occurs on the media may hit the head, and it may cause the media jam or the damage of the head.	The tension applied on the media is too strong. Lighten the tension bar.



About counter weight

- Counter weight is not attached to this machine when you purchase the product.
- The maximum weight for weights to be attached to one place is 700 g. Check the tension of the media and attach an appropriate number of weights.
- By changing where to attach counter weight is not attached to this machine when you purchase the product. The maximum weight for weights to be attached to one place is 700 g (large: 100 g x 2 sheets, small: 50 g x 10 sheets), you can change the weight of tension bar.
- If the same amount of weight is put on the upper side or the lower side, counter weight is heavier when that amount of weight is put on the upper side. Counter weight is put at four points in total: two points on the feeding side (left and right) and two points on the take-up side (left and right). Put weights in such a way that the weight at each of the four points becomes the same. If it is not the same, tension bar may bend and print quality may become worse.
- Not to lose the unused counter weight, put it in the storage box.

About weight adjustment spring

- A green spring is attached when you purchase the product. You can change the weight of tension bar by changing the spring type or removing the spring.
- Weight adjustment spring can be adjusted at four points in total: two points on the feeding side (left and right) and two points on the take-up side (left and right). For the strength for weight adjustment spring, set the same value at each of the four points. If the strength is not the same, tension bar may bend and print quality may become worse.
- Wear gloves to replace or remove weight adjustment spring. The shaft to which the spring is attached is coated with grease. Do not wipe off grease coating the shaft.

How to adjust tension bar

- Adjust the weight of tension bar by changing weight adjustment spring.
- If tension bar is too light in weight, add counter weight. If tension bar is too heavy, remove a weight.
 - To increase the weight, we recommend changing it a little by little.
 - Not to lose the unused weight adjustment spring, put it in the storage box.



- The correlation diagram between counter weight and weight adjustment spring is shown as below. Use it as reference.

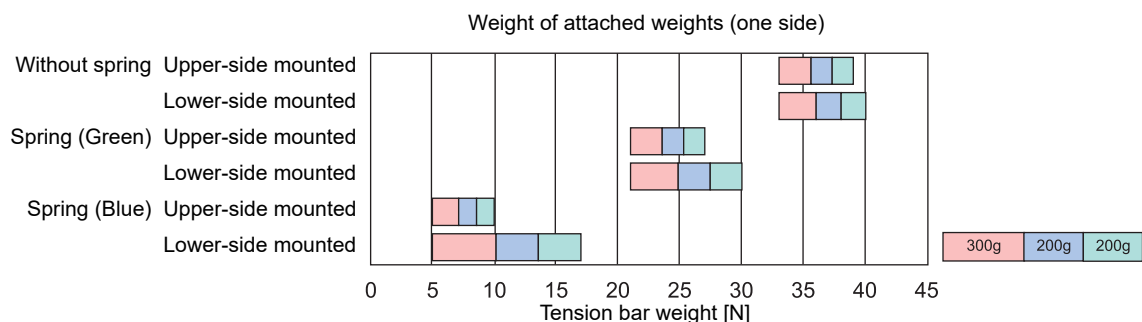

- Attach the counter weight and weight adjustment spring after adjusting the media feeding correction amount in P.2-30 "Feed settings".

Attach the weight adjustment spring

1 Loosen the screws and remove the weight adjustment shaft fixing plate.

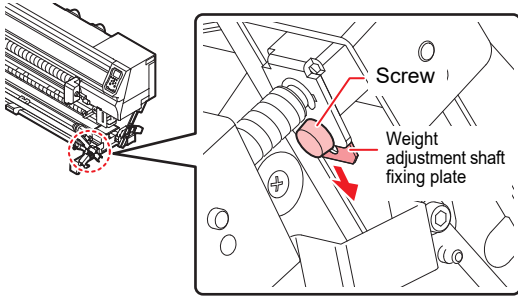

2 Pull out the weight adjustment shaft.
 • Make sure that the holes on the weight adjustment shaft are directed horizontally, and then pull the shaft out.

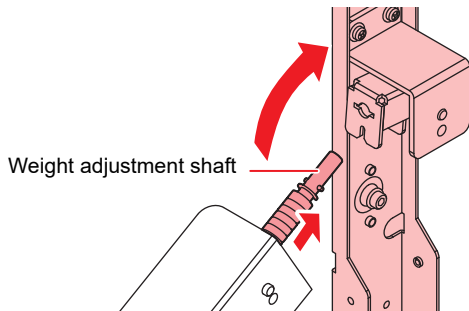

3 Remove the currently attached weight adjustment spring.
 • Alternatively, replace it with another spring.

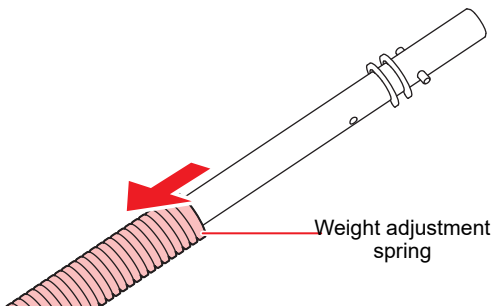

4 Attach the weight adjustment shaft.
 • Be careful about the orientation of the guide for attaching the weight adjustment shaft when attaching the shaft.

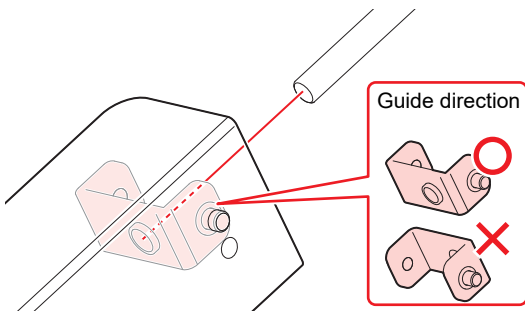

5 Insert the weight adjustment shaft with the holes on it directed horizontally, and insert the weight adjustment shaft fixing plate as far as it goes.

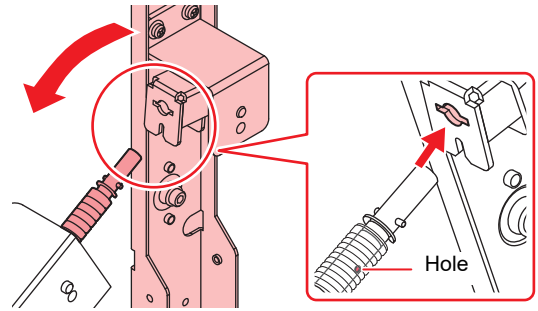

6 Tighten the screws.

Installing the counter weight for adjusting the tension-bar weight (1)



- If the large / small two types of counter weight (large (100 g x 4 sheets) / small (50 g x 20 sheets)) are attached, install a counter weight in the following manner.
- Check the tension of the media and attach an appropriate number of weights.

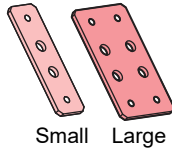

Install the proper number of the counter weight depending on the media type.

You can attach the counter weight up to 12 (Large : 2, Small : 10) each for right and left.

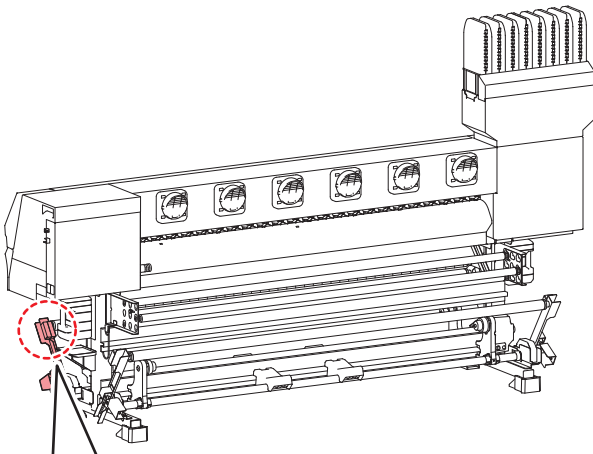

Counter weight

A weight can be attached to either the top surface or bottom surface of tension bar.

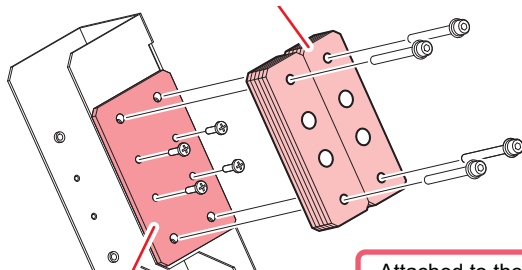

Do not remove the weight that was originally attached.

Attached to the under surface

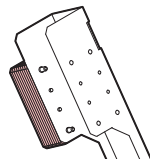

Installing the counter weight for adjusting the tension-bar weight (2)



- If the counter weight (50 g x 28 sheets) of the right figure is attached, install a counter weight in the following manner.
- Check the tension of the media and attach an appropriate number of weights.

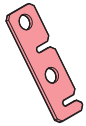

Install the proper number of the counter weight depending on the media type.

You can attach the counter weight up to 14 each for right and left.

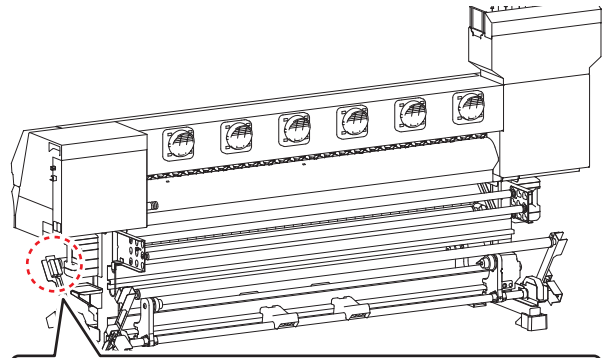

Do not remove the weight that was originally attached. Also, do not remove the screws retaining the weight.

Mounting screw

Loosen the screws when removing the counter weight.

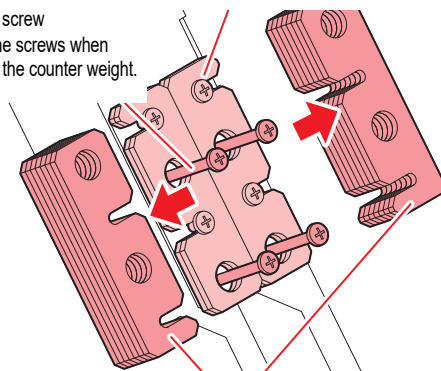

Counter weight



- If install / remove the counter weight of the bottom, please sufficiently loosen the mounting screws. If the screws are not loose enough, the counter weight will be caught by the originally attached screws, and it may not be removed.

Setting the torque limiter (cloth media)

The tension roller have the torque limiter. By adjusting the torque limiter, you can change the rotating strength of the roller. (At the factory, the torque limiter was set to the strongest.)

If you cannot adjust media feeding by counter weight adjustment, adjust torque limiter.

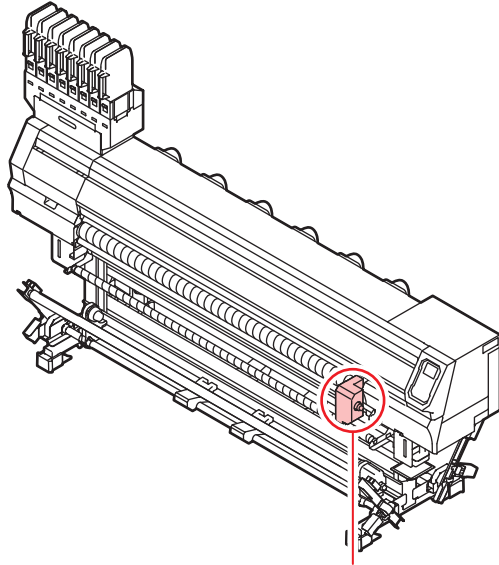

Torque limiter

- Clockwise turn :
Increases torque (a thicker media)
- Counterclockwise turn :
Decreases torque (For light media)

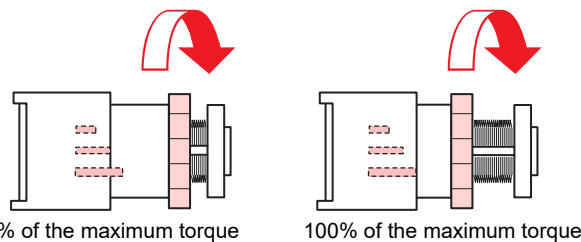
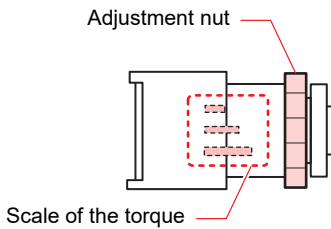

50% of the maximum torque

100% of the maximum torque

- Important!**
- **When the torque limiter is adjusted too weak ;**
The media can not be taken up firmly.
 - **When the torque limiter is adjusted too strong ;**
The slack may occur depending on the media and cause influence on the image quality.
 - **When the media is stretched tight, if tension roller runs without set ;**
The level of torque limiter is adjusted too high. Reduce the level of torque limiter or increase the weight of tension bar.

Mounting the fabric roller

When printing on a loose fabric, the ink remained on the back of the fabric may attach to the tension roller, and the ink may stain the fabric media.

With the fabric roller mounted, the stain of the fabric media can be avoided by the roller removing the attached ink to the tension roller.

Important!

- Fabric is not wrapped around the fabric roller before shipping. Prepare the well-absorbed fabric with the following size.
- Material: Cotton sheeting, cotton broadcloth or the like
- Size: 195 cm x 70 cm

1 Remove the fabric roller.

- The fabric roller is at the under of the tension roller.

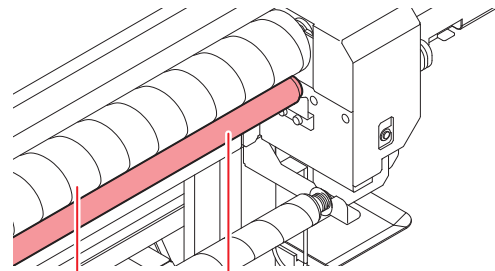

tension roller

Fabric roller

2 Wrap a fabric around the fabric roller.

- As shown on the bellow, fit a fabric with the roller.

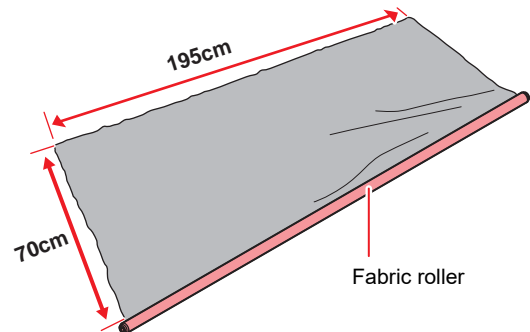

Fabric roller

- (1) Secure the fabric and the roller with an adhesive tape.

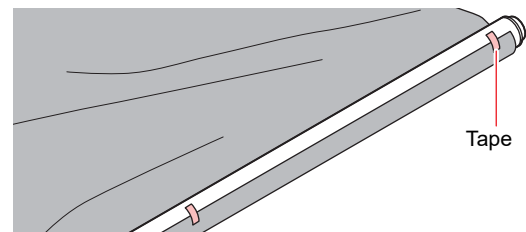

Tape

- (2) Wrap the fabric around the roller, and secure with an adhesive tape.

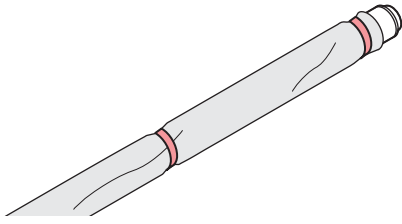

3 Mount the fabric roller with the fabric wrapped.

- Mount the fabric roller in the slot on the back of the tension roller.
- Fit the shaft holder into the slot on both sides of the fabric roller.
Adjust the bearing position on both ends of the fabric roller.
Loosen the screw of the bearing so that the fabric roller contacts the tension roller.

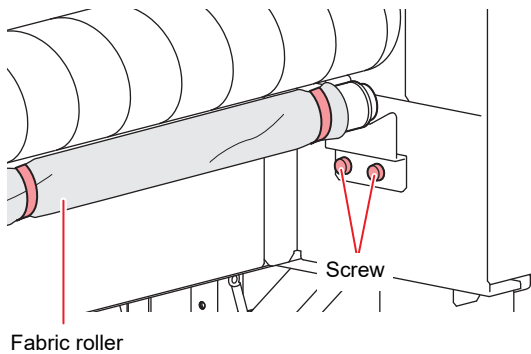

4 Turn the tension roller manually, and check it turns smoothly.

- If the tension roller does not turn smoothly, check the mounted position of the fabric roller.

Setting a Media

This machine can be used with a roll media and leaf media.

For usable media, refer to (☞ P.1-16 "Usable sizes of media").



- Take care not to drop the media on your foot when setting the media. It may cause an injury due to the media.
- When setting a roll media, work by two or more people. Otherwise, you may hurt your back by the weight of the roll media.
- Adjust the head height prior to setting the media. If the head height is adjusted after the media is set, this may cause a media jamming, deterioration of the print quality or head damage.
- Depending on the type of media, it may be necessary to change the platen. (Tx300P-1800 MkII)



- With this machine, you can set media on the right side or in the center. When setting media, be sure to set it so that it covers one of the two media sensors on the back of this machine.
- If setting the media in the center, use the take-up extension cable.
- The head height is adjustable according to the purpose of use.

Setting up the roll media (cloth media)

Placing roll (cloth) media into the printer may sometimes require use of the tension bar.

The media is detected once in position. (☞ P.2-26)



- Use the cloth media platen.
- When placing the media in the center, use the take-up extension cable.
- Adjust the head height to suit the intended use.

Using the tension bar

This section describes how to set up the media using the tension bar for both feeding and takeup.

The route for setting the fabric media is as shown in the following diagram.

Prior to setting the media, if you understand the routing of the media, you can perform the setting of the media smoothly.



- Check to confirm that "SELECT USE TENSION-BAR" has been correctly set.
- Before setting fabric media, check that around the grit roller is not stained. If it is stained, clean it.
- Before setting media by using tension bar, check that direct-connection unit is attached to feeding/take-up device. If torque limiter is attached, replace it with direct-connection unit by referring to P.2-9.

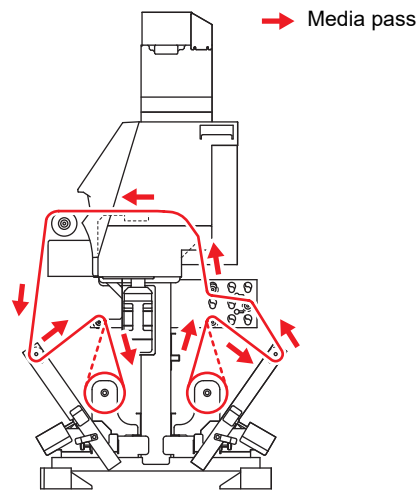

1

Attach the ink receiving spacer.

- Attach the ink receiving spacer, refer to (☞ P.2-7 "Spacer installation (cloth media)")

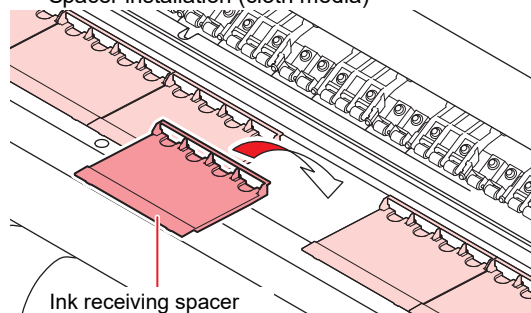

2

Close the front cover and check the clamp lever is lowered.

- The screen for "SELECT USE TENSION-BAR" is displayed.

3

Select how to use tension bar according to the media setting method.

- In this case, select "FEEDING & TAKE".
(DL= direct-connection unit, TL= torque limiter
- - = unit OFF)
- Press [▲][▼] to select "FEEDING&TAKE" and press the [ENTER] key.

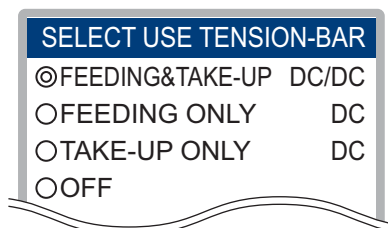

4 Fix feeding tension bar and take-up tension bar into their locked positions.

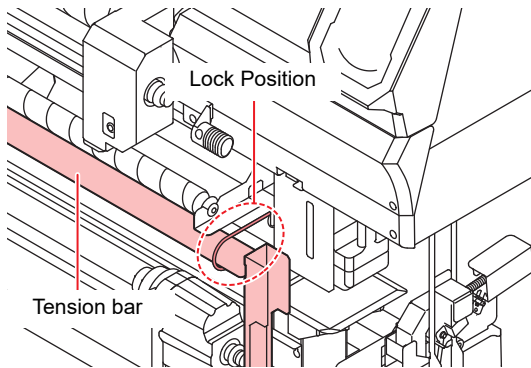

5 Attach folding bar according to the media to be set.

- To stabilize the tension on the feeding side, attach folding bar in an appropriate position to suit the media to be set.
- The position in the figure below is our recommended attachment position. Even when folding bar is attached in this position, if the media becomes loose or has vertical creases, adjust the tension to suit the media you use by referring to P.2-20.

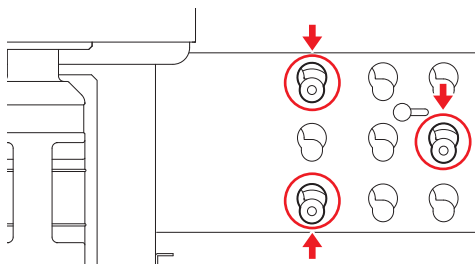

- Loosen the pinch screws on the outside (left and right) of the folding bar mounting plate.
 - The folding bar press becomes movable freely.
- While holding the loosened pinch screws, move the folding bar press towards you.
 - Move until it hits the stopper.

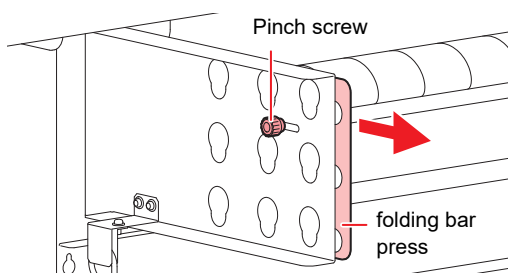

- Insert and move folding bar downward.
 - Mount folding bar into the lower part of the potbelly-type hole.
 - Check the mounted position of folding bar. If inserted in a wrong position, folding bar cannot be fixed.

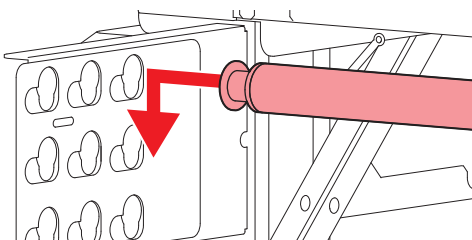

- Move the folding bar press toward the machine and fix it.
 - Do the same for both the left and right folding bar mounting boards.

6 Set the left end of the core of the roll media on the left roll holder.

- Push the roll media onto the roll holder until the roll core is all the way seated.

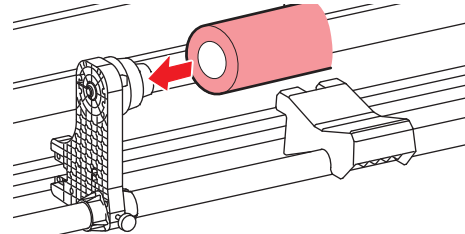

7 Loosen the screw of the right side feeding device then insert the core of the roll media.

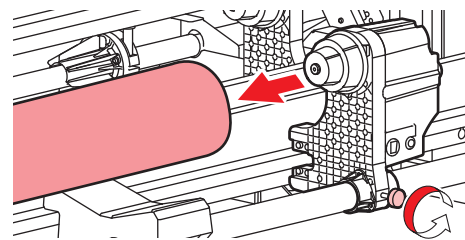

8 Fix feeding legs on the floor.

- Be sure to fix feeding legs on the floor to prevent the shaft fixing feeding device from bending due to the weight of the set the media.

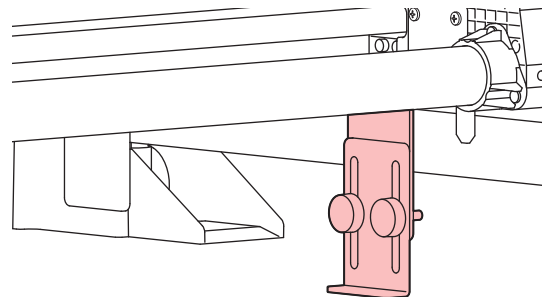

9 Lower feeding tension bar and take-up tension bar.

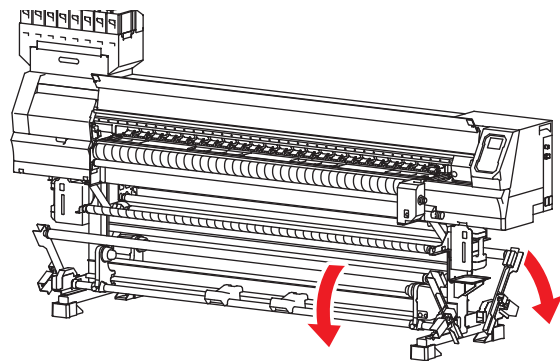

10 Raise the clamp lever in the rear of this machine.

- If the clamp lever is kept lowered, feeding device will be locked and you will become unable to pull out the media in and after step 11.

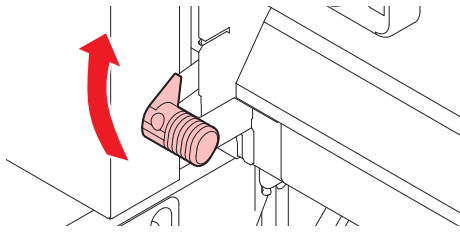

11 Insert the roll media in this machine.

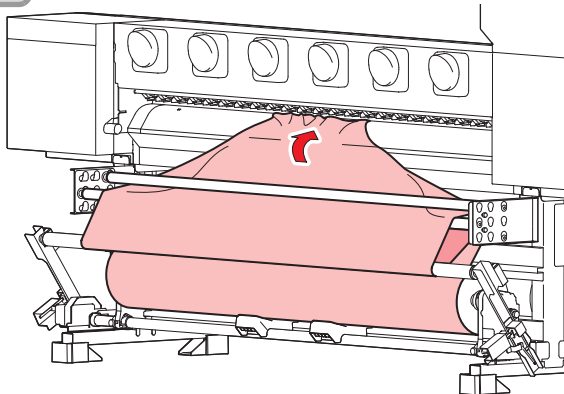

- (1) Pull out the media so that it reaches the head of the platen.
- (2) Use feeding tension bar and folding bar to pass the media so that appropriate tension is applied to the media.
- (3) Insert the media between the platen and the pinch roller.
 - Feed the media forward to such an extent that you can catch hold of the media from the front of the machine.

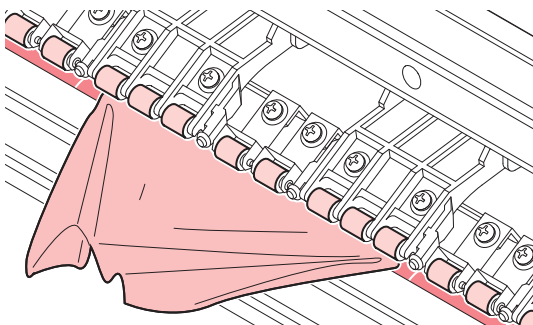

- (4) Lower the clamp lever from the back of the machine.
 - The media will be held.

12 Open the front cover and pull out the roll media out.

- (1) Open the front cover.
- (2) Raise the clamp lever from the front of this machine.
 - To raise the clamp lever, we recommend holding the media to prevent it from falling on the feeding side.

- (3) Pull out the roll media gently.
 - Pull out the media diagonally upwards. If you pull out the media horizontally, the media may contact the grid rollers and get scratched.
 - Pull out the media to such an extent that the media covers tension roller.

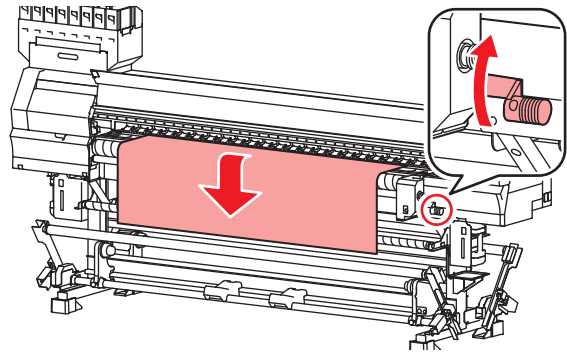

13 Remove creases from the media and lower clamp lever.

- Lightly pull a few areas of the media to remove creases, confirm that each edge of the media (front and back) is linear, and then lower the clamp lever.

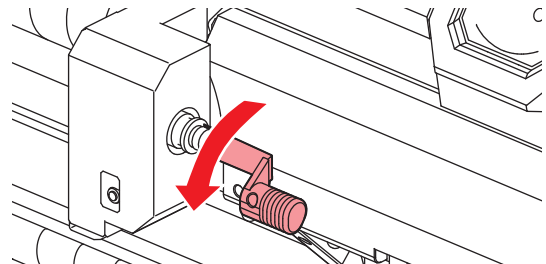

14 Close the front cover.

15 Set an empty core of the roll media on the take-up device, and take-up legsfix take-up legs on the floor.

- After setting the empty core, fix take-up legs on the floor.

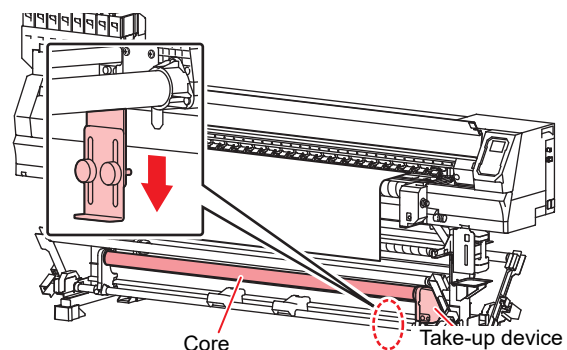

16 Check that the media is set on the feeding side, and press the **ENTER** key.

- Feeding tension bar starts operating, and detects and adjusts the media on the feeding side.
- If the machine cannot detect the media, raise the clamp lever and carry out the operations from step 9 again.

17 Secure the media on the take-up device.

- (1) Press [▼] to feed the media forward until the media contacts the floor.

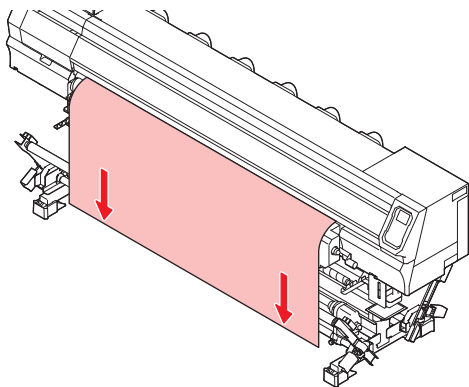

- (2) Pass the media from the back of folding bar through take-up tension bar.
 (3) Fix the middle of the media with adhesive tape.
 (4) In the same manner, fix the left side and right side of the media.
- Make sure that there is no slack or wrinkle on the media in such condition that the roll media is pulled to right and left evenly, and then stick the tape.

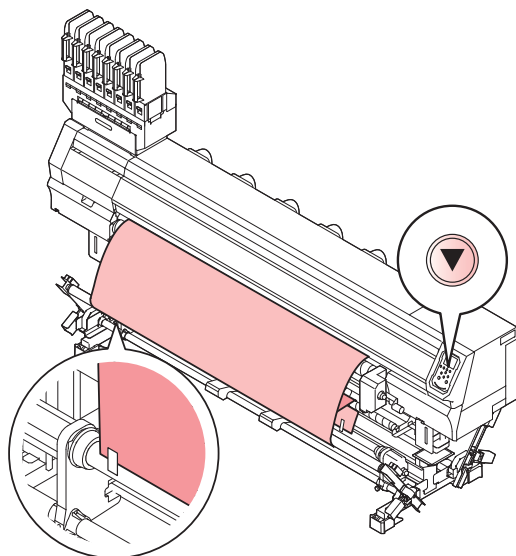
**Important!**

- When setting wider media, fix five positions and more of the media with tape etc. The more fixing positions are, the more tension of the media becomes even.
- When the position of the fabric set and the position of the core is out of alignment, loosen the screw of the roll holder and make adjustment so that the core comes to the appropriate position.
- From the roll of the feeding side, see and check the position of both ends of the fabric are aligned with the both ends of the roll on the feeding side.

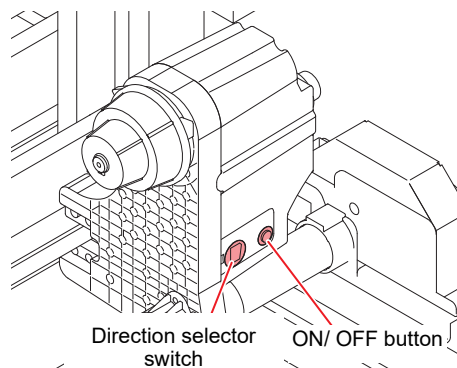
18 With switches of the take-up device, roll up the media about once.

- (1) Set the take-up direction using the direction selector switch on the left, turn the ON/OFF button on the right to ON, and then take up the media.
 (2) When the media stretched tight turn the right ON/OFF button to OFF to stop.
- Roll the media around the paper core one time or more.
 - If the amount of media pulled out in advance is not sufficient for rolling the media around the paper one time or more, press [▼] again to feed the media and roll the media around using take-up device.

Important!

- If the amount of the media is too short for taking up the media around the paper core, be sure to press [▼] to feed the media and then take up the media by take-up device.
Taking up the media forcibly may cause malfunction.

19 Open the front cover, and hold the media with the fabric retainer gently.

- Set the media so that it does not extend to the right of the V-groove on the platen.
- When using thick media, adjust the height of fabric retainer (P.2-20).

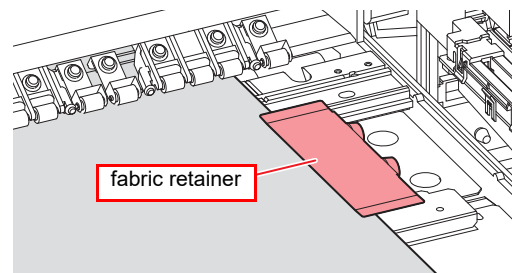
**Important!**

Be sure to use the fabric retainer. Using it is effective in the following respects.

- Avoids lifting an edge of the fabric used by curl, warpage, or pilling.
- Avoids passing ink mist through to the back while printing.



- When installing the media, align the media's right edge with the groove in the platen. Placing the media rightward of the groove will make it rise up if it moves obliquely, and this could cause damage to the head.
- If a media is misaligned to the right/left more than fixed position, a error message "MEDIA SET POSITION R" is displayed. Set the media again.

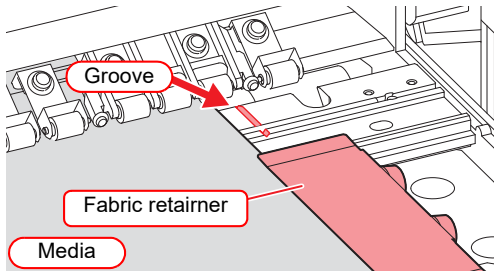

20 Close the front cover, and press the **ENTER** key.

- Take-up tension bar starts operating, and detects and adjusts the media on the take-up side.
- When the detection of the media on the take-up side is completed, the detection operation continues to be performed on the winding diameter of the media.
- When the detection operation of the winding diameter in "MEDIA DETECT" of the machine set up is "MANUAL" (P.3-16), the detection operation of the winding diameter is not performed automatically. Please refer to (P.2-26) "About media winding diameter setting" and enter the winding diameter.
- If the media cannot be detected, carry out the operations from step 2 again.

21 When the detection operation of the winding diameter is completed, press the **ENTER** key.

- Detects the media width.
- When [MEDIA DETECT] of the machine setup is "MANUAL" (P.3-16), refer to P.2-26 "Setting of the manual media width setting" and enter the media width.
- When [MEDIA RESIDUAL] of the machine setup is "ON" (P.3-16), the screen for entering media remaining amount is displayed after detecting the media width. (P.2-27)



- When you finish setting the media, print any data to check that media tension is applied appropriately. If white or black lines appear in a printed image, it means that tension suitable for the set media is not applied. Change the position of folding bar or the weight adjustment for feeding/take-up tension bar and check until an appropriate position is set.

How to adjust fabric retainer

Adjust the height of the stainless steel plate in line with the thickness of the fabric.

1 Remove the fabric retainer.

- Slide the fabric retainer to the edge of the platen and remove it.

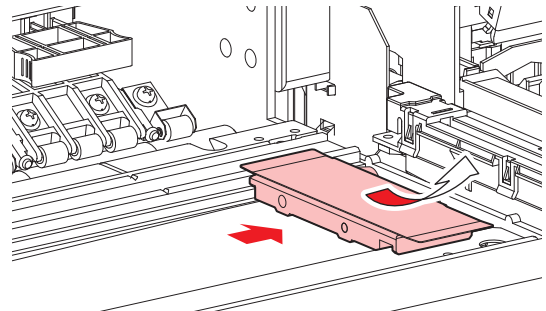

2 Loosen the knob-screws, and adjust the height of the stainless steel plate in line with the thickness of the fabric.

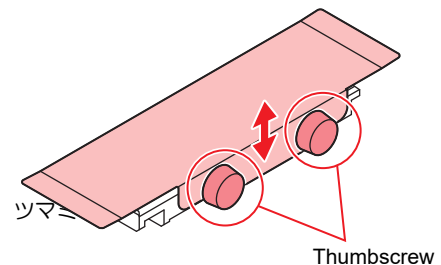

- When a heavy fabric is pressed and held, set the height of the head in accordance with the thickness of the fabric. If the height of the head is kept low, it may cause the break of the head.

How to adjust the folding bar

To perform printing on media with appropriate tension, it is necessary to adjust the mount position of the folding bar and the number of bars.



- When a heavy fabric is pressed and held, set the height of the head in accordance with the thickness of the fabric. If the height of the head is kept low, it may cause the break of the head.

● If the tension of the media is low

Increase the winding angle.

The tension applied to the media becomes higher.

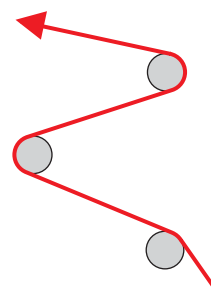

● If the tension of the media is high

Decrease the winding angle.

The tension applied to the media becomes lower.

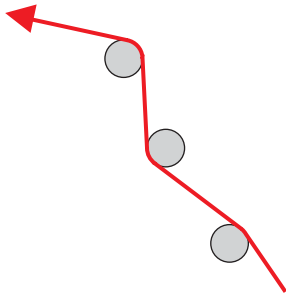

Setting roll media without using tension bar

The figure below shows an example of routing when setting cloth media without using tension bar.

When setting media, read the following notes carefully.

- Important!**
- To set roll media without using tension bar, replace direct-connection unit attached to feeding/take-up device with torque limiter that comes with the product.
 - To print continuously without using tension bar, limit the media length to approximately 10 m. If you want to continuously print more than 10 m, use tension bar to set media.

Prior to setting the media, if you understand the routing of the media, you can perform the setting of the media smoothly.

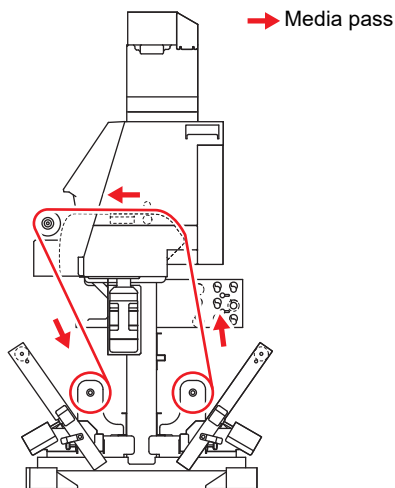

- Important!**
- Before setting fabric media, check that around the grit roller is not stained. If it is stained, clean it.
 - To set roll media without using tension bar, adjust the media tension by using folding bar and torque limiter. (P.2-20)

1 Close the front cover and check the clamp lever is lowered.

- The screen for "SELECT USE TENSION-BAR" is displayed.

2 Select how to use tension bar according to the media setting method.

- In this case, select "OFF".
(DL= direct-connection unit, TL= torque limiter
-- = unit OFF)
- Press [▲][▼] to select "OFF" and press the [ENTER] key.



- Important!**
- If you switch both "FEEDING TENSION BAR" and "TAKE-UP TENSION BAR" off in "SETTING FEEDING AND TAKE-UP UNIT" in the machine setup (P.2-9), the "SELECT USE TENSION-BAR" screen does not appear. (The media selection screen appears.)

3 Set media on the feeding side.

- Perform the operations from steps 4 to 8 described in P.2-16 "Using the tension bar".
- When using paper media, the tension bar must be moved.

- 1) Hold the tension bar toward the rear of the main unit.

Feeding side tension bar

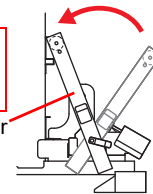

- 2) Mount the roll media.

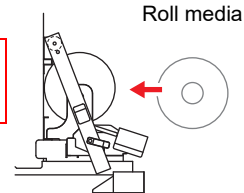

- 3) Move the tension bar back to its original position.

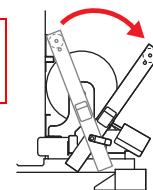

4 Feed the media to the take-up side and prepare an empty paper core in take-up device.

- Perform the operations from steps 11 to 15 described in "P.2-16 "Using the tension bar"".

5 Fix the media to the paper core and mount fabric retainer.

- Perform the operations from steps 17 to 19 described in "P.2-16 "Using the tension bar"".

6 Press [←] to select "ROLL".

- Detects the media width.
- When [MEDIA DETECT] of the machine setup is "MANUAL" (P.3-16), refer to P.2-26 "Setting of the manual media width setting" and enter the media width.

- When [MEDIA RESIDUAL] of the machine setup is "ON" (☞ P.3-16), the screen for entering media remaining amount is displayed after detecting the media width. (☞ P.2-27)

Setting up the roll media (transfer paper) (Tx300P-1800 MkII only)

Only the Tx300P-1800 MkII supports paper media (transfer paper).

Setting up the roll media (paper media) does not require use of the tension bar.

When setting media, read the following notes carefully.

Important!

- To set roll media without using tension bar, replace direct-connection unit attached to feeding/take-up device with torque limiter that comes with the product.
- To print continuously without using tension bar, limit the media length to approximately 10 m. If you want to continuously print more than 10 m, use tension bar to set media.

The path when setting up the paper media (transfer paper) is shown in the following figure.

Prior to setting the media, if you understand the routing of the media, you can perform the setting of the media smoothly.

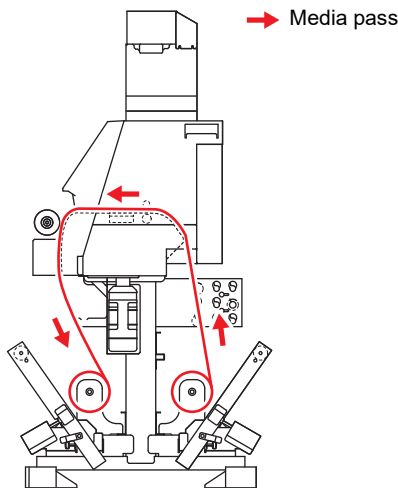

- If a tension roller is provided, pass the media between the roller and the main unit.
- Set the folding bar in a hole where it does not interfere with the media.

1 Remove the take-up folding bar.

- Remove the take-up folding bar to prevent it from interfering with the media.

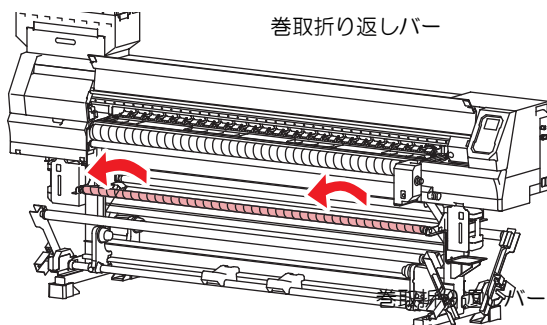

2 Mount the take-up folding bar in the feed folding bar holder.

- Mount the removed take-up folding bar in the feed folding bar holder at the rear of the machine.
- Mount the take-up folding bar and feed folding bars in the positions shown in the following figure.

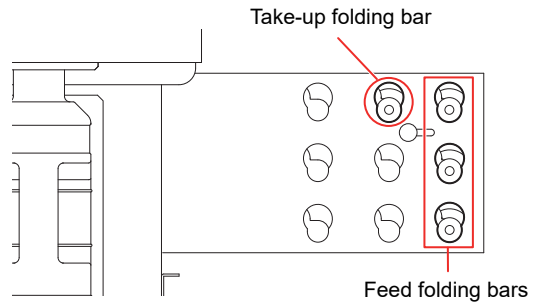

3 Close the front cover and check the clamp lever is lowered.

- The screen for "SELECT USE TENSION-BAR" is displayed.

4 Select how to use tension bar according to the media setting method.

- In this case, select "OFF".
(DL= direct-connection unit, TL= torque limiter
-- = unit OFF)
- Press [▲][▼] to select "OFF" and press the [ENTER] key.

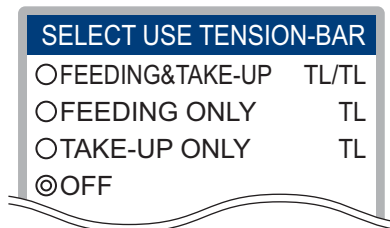

Important!

- If you switch both "FEEDING TENSION BAR" and "TAKE-UP TENSION BAR" off in "SETTING FEEDING AND TAKE-UP UNIT" in the machine setup (☞ P.2-9), the "SELECT USE TENSION-BAR" screen does not appear. (The media selection screen appears.)

5 Set media on the feeding side.

- Perform the operations from steps 4 to 8 described in P.2-16 "Using the tension bar".
- When using paper media, the tension bar must be moved.

1) Hold the tension bar toward the rear of the main unit.

Feeding side tension bar

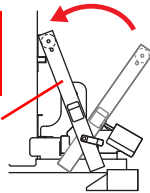

2) Mount the roll media.

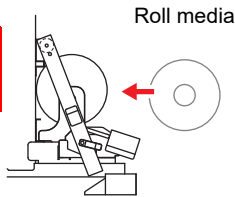

3) Move the tension bar back to its original position.

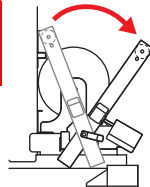

6 Pull out the roll media out.

- (1) Open the front cover.
- (2) Raise the clamp lever from the front of this machine.
- (3) Pull out the roll media gently and then stop pulling when locked lightly.

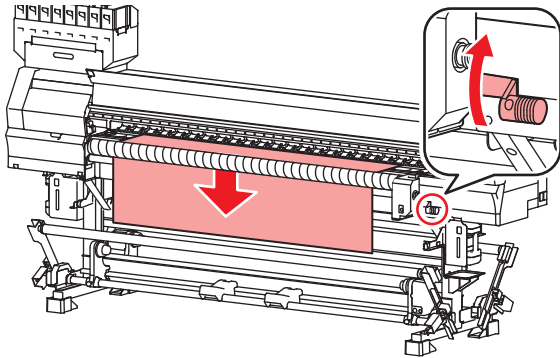

- If a tension roller is provided, pass the media between the roller and the main unit.
- If you set the roll media in the center, the lock will not engage.

7 Make the roll media even then lower the clamp lever.

- Pulling several positions of the media lightly, Lower the clamp lever after confirming that the amount of the roll media pulled out is almost even.

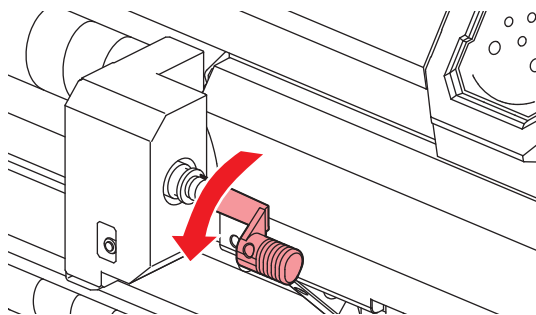

8 Hold the media with the media press gently.

- Set the media so that no media sticks out from the right end pinch roller to the right side.
- When using a thick media, remove the media press from the media before printing.

In this case, set the machine setup of "In this case, set the machine setup of "Setting the Display of Media Detection" to "MANUAL" (P.3-16), and refer to P.2-26 "Setting of the manual media width setting" and set the media width.

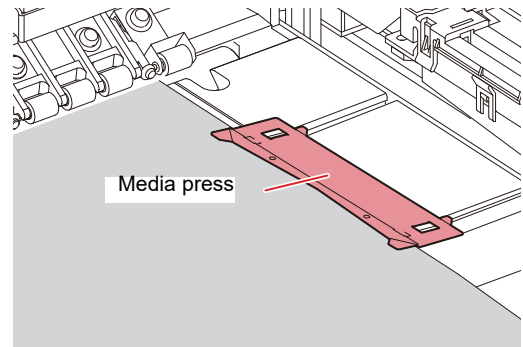

- When installing the media, align the media's right edge with the groove in the platen. Placing the media rightward of the groove will make it rise up if it moves obliquely, and this could cause damage to the head.
- This machine detects the media width using the media presses set to the left and right of the media.
Be sure to set the media presses.
- If a media is misaligned to the right/left more than fixed position, a error message "MEDIA SET POSITION R" is displayed. Set the media again.

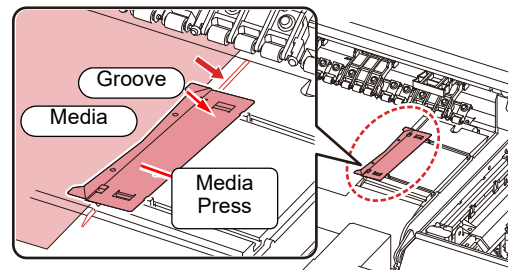

9 Close the front cover.

10 Set an empty core of the roll media on the take-up device.

- After setting the empty core, set down the take-up legs.

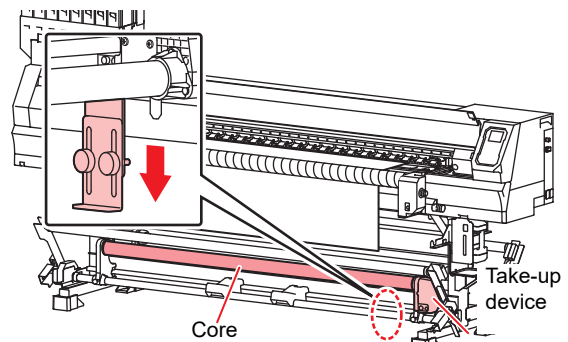

11 Fix the media to the empty core.

- (1) Feed the media up to the core of the roll media of the take-up device by pressing [▼].
- (2) Fix the middle of the media with adhesive tape.
- (3) In the same manner, fix the left side and right side of the media.
 - Make sure that there is no slack or wrinkle on the media in such condition that the roll media is pulled to right and left evenly, and then stick the tape.

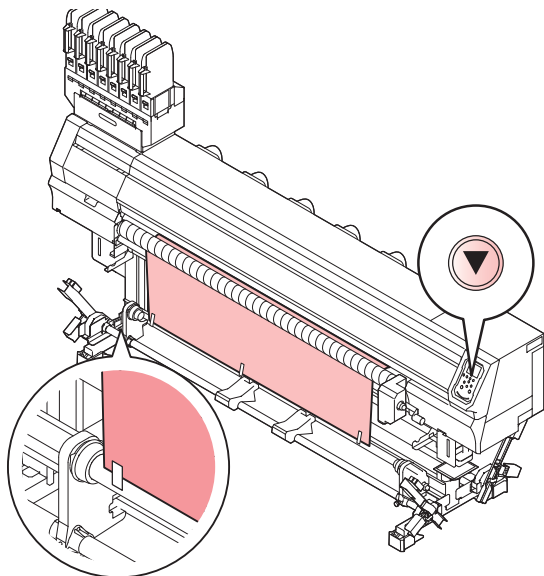

12 Press [←] to select "ROLL".

- Detects the media width.
- When [MEDIA DETECT] of the machine setup is "MANUAL" (P.3-16), refer to P.2-26 "Setting of the manual media width setting" and enter the media width.
- When [MEDIA RESIDUAL] of the machine setting is "ON", the screen for entering media remaining amount is displayed after detecting the media width. (P.2-27)

13 Set the vacuum fan output.

- This must always be set to "HIGH" when using paper media. For more information on the settings, refer to "Setup" → "Vacuum Fan". (P.3-8 "Setting of Vacuum Fan")

SETUP 1	2/3
MARGIN/LEFT	HOST
MARGIN/RIGHT	HOST
VACUUM	HOST
FEED SPEED	HOST
AUTO CLEANING	>
<<	>>

Setting leaf media (cloth media)

Unlike roll media, leaf media does not need to be retained with the roll holders.



- Use the corresponding platen for cloth or paper media. Check to confirm that the correct platen has been mounted. (Tx300P-1800 MkII)

1 Set the FEEDING UNIT and TAKE-UP UNIT to "OFF" in "Feeding/ Take-up device" of the machine setup. (P.2-9)

2 Open the front cover, and then raise the clamp lever.

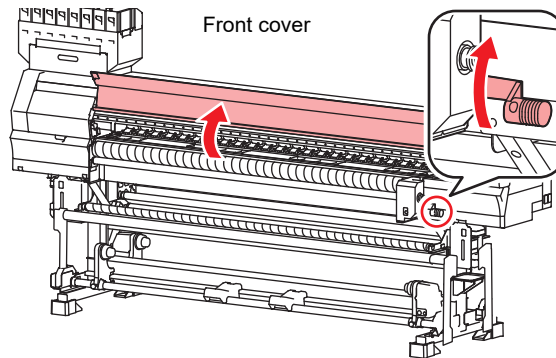

3 Insert the leaf media between the platen and the pinch rollers, and push down the clamp lever.

- Set the media so that no media sticks out from the right end pinch roller to the right side.

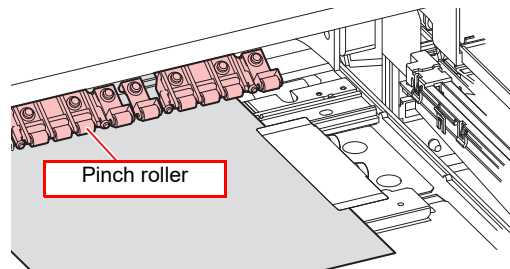

4 Hold the media with the fabric retainer gently.

- Set the media so that it does not extend to the right of the V-groove on the platen.
- When using a thick media, remove the fabric retainer from the media before printing. In this case, set the machine setup of "Setting the Media Detection" to "MANUAL" (P.3-16), and refer to P.2-26 "Setting of the manual media width setting" and set the media width.

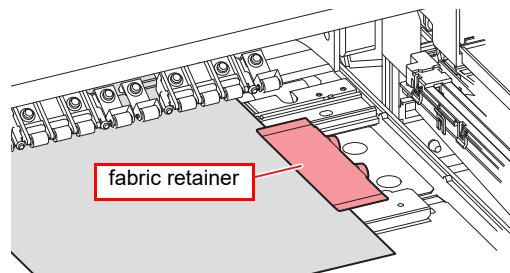

5 Close the front cover.

- Set the media straight.

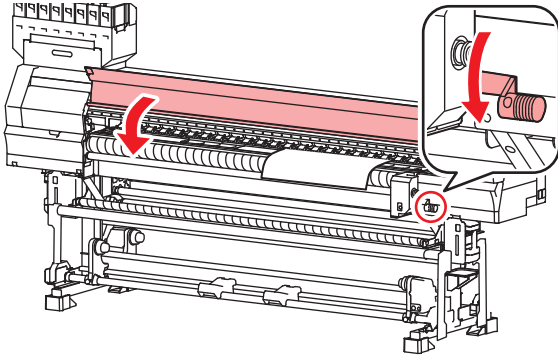

Important!

- For the leaf media, use only a withy one. When using the leaf media, the take-up device is invalid. If the set media is not withy, the printing face will not become flat and the media will jam.
- Set media long enough to cover tension roller. Otherwise, the media may be caught between tension roller and the fabric roller and get jammed.

6 Press to select "LEAF" .

7 The media detection is started.

- (1) The media width is detected.
- (2) The media is fed then the rear end of media is detected.
- (3) It returns to the Local when the detection is completed.

Setting leaf media (Transfer Paper) (Tx300P-1800 MkII only)

Unlike roll media, leaf media does not need to be retained with the roll holders.



- Use the corresponding platen for cloth or paper media. Check to confirm that the correct platen has been mounted. (Tx300P-1800 MkII)

1 Set the FEEDING UNIT and TAKE-UP UNIT to "OFF" in "Feeding/ Take-up device" of the machine setup. (P.2-9)

2 Open the front cover, and then raise the clamp lever.

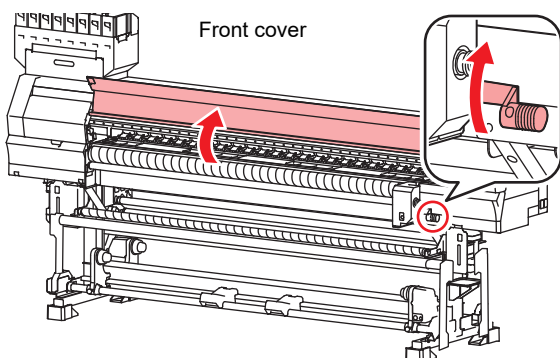

3 Insert the leaf media between the platen and the pinch rollers, and push down the clamp lever.

- Set the media so that no media sticks out from the right end pinch roller to the right side.

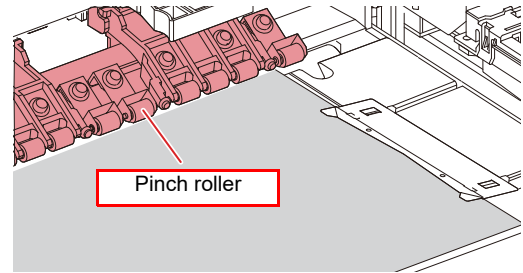

4 Hold the media with the Media Press gently.

- Set the media so that it does not extend to the right of the V-groove on the platen.
- When using a thick media, remove the fabric retainer from the media before printing. In this case, set the machine setup of "Setting the Media Detection" to "MANUAL" (P.3-16), and refer to P.2-26 "Setting of the manual media width setting" and set the media width.

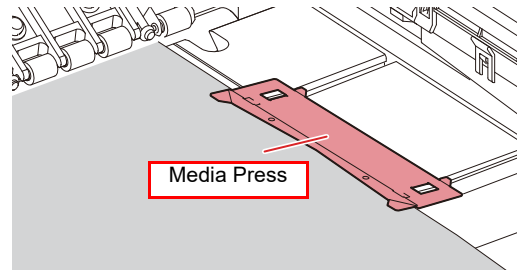

- When installing the media, align the media's right edge with the groove in the platen. Placing the media rightward of the groove will make it rise up if it moves obliquely, and this could cause damage to the head.
- This machine detects the media width using the media presses set to the left and right of the media. Be sure to set the media presses.
- If a media is misaligned to the right/left more than fixed position, a error message "MEDIA SET POSITION R" is displayed. Set the media again.

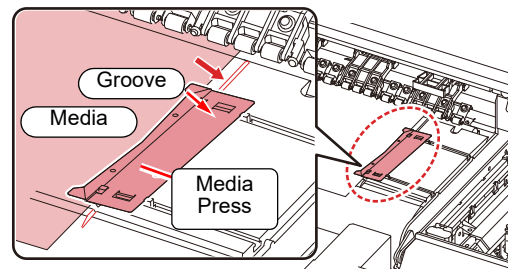

5 Close the front cover.

- Set the media straight.

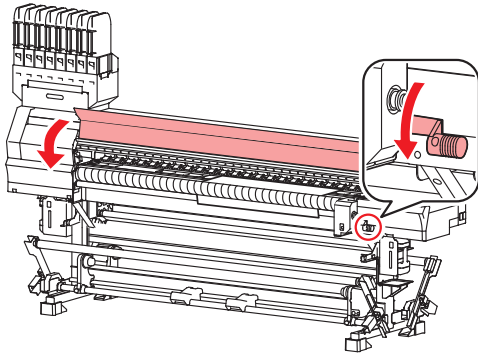

- When setting up the media, pull out at least 150 mm from the platen and pass this between the tension roller and main unit. The media may lift up and damage the head if not routed correctly.

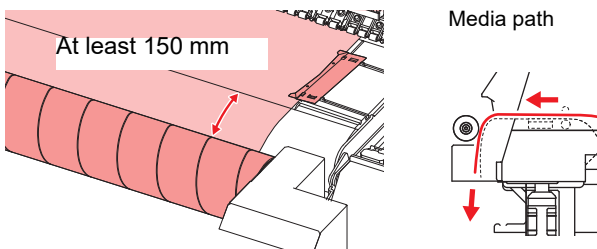

- For the leaf media, use only a withy one. When using the leaf media, the take-up device is invalid. If the set media is not withy, the printing face will not become flat and the media will jam.

6 Press **[▶]** to select "LEAF" .

7 The media detection is started.

- (1) The media width is detected.
- (2) The media is fed then the rear end of media is detected.
- (3) It returns to the Local when the detection is completed.

Media information setup

If "MEDIA DETECT" in the machine settings is set to "MANUAL" (P.3-16), the media will not be detected automatically when it is set.

Once the screen appears, enter the corresponding details manually.

About media winding diameter setting

When the detection operation of the winding diameter in "MEDIA DETECT" of the machine set up is "MANUAL" (P.3-16), set the winding diameter as follows.

1 Set the roll media in the tension bar and display the winding diameter input screen.

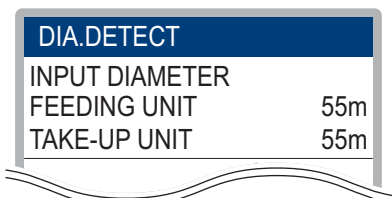

2 Enter winding diameter of feeding unit.

- (1) Press **[▲]** **[▼]** to select "FEEDING UNIT Unit", then press the **[ENTER]** key.
- (2) (Press **[▲]** **[▼]**) to input the media outer diameter (diameter) of the feeding unit and press the **[ENTER]** key.

3 Enter winding diameter of take-up unit.

- (1) Press **[▲]** **[▼]** to select "TAKE-UP UNIT" and press the **[ENTER]** key.
- (2) Press **[▲]** **[▼]** to input the media outer diameter (diameter) of the take-up unit and press the **[ENTER]** key.

4 Press **[FUNC2]** (**OK**) key.

Setting of the manual media width setting

When **[MEDIA DETECT]** of the machine setup is "MANUAL" (P.3-16), set the media width in the following method.

1 Display the "MEDIA DETECT" screen.

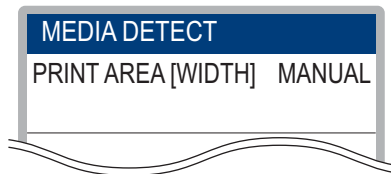

2 Select the print area setting method.

- When setting the print area, use either "Manual" to set the right and left edge of the media using the jog key, or "Media width input mode" to set the right edge of the media after inputting media width.
- When "Manual" is selected, proceed to Step 3. And when "Media width entering mode" is selected, proceed to below.

- (1) Press **[▲]****[▼]**, and enter the media width.
- (2) Press the **[ENTER]** key, and perform after step3.

3 Press **[◀]****[▶]** to set a light point of the LED pointer to the right edge position of the media.

- Press **[◀]****[▶]** to move the carriage, and align the built-in LED pointer with the right edge of the media.

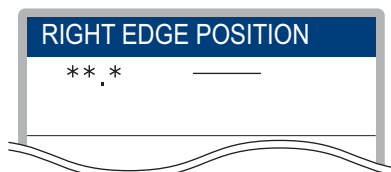

4 Press the **ENTER** key.

- Next, the screen to enter the left edge position of the media is displayed.
- When "Media width entering mode" is selected on step 2, this setting is end without display this screen.

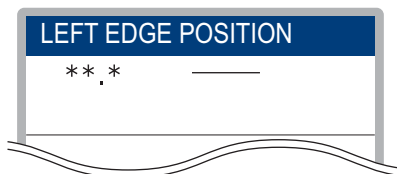
**5** Press **◀▶** to set a light point of the LED pointer to the left edge position of the media.

- In the same manner as in step 3, align the light of the LED pointer to the left edge of the media.

6 Press the **ENTER** key.**Important!**

- If you do not perform over printing, be careful not to set the position beyond the media range, as it may cause printing or outside the media.

Entering the media remaining amount

When [MEDIA RESIDUAL] of the machine setup is "ON" (P.3-16), the screen for entering media remaining amount is displayed after detecting the media width.

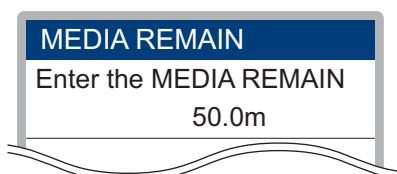
1 Display the screen for entering media remaining amount.**2** Press **▲▼** to enter the media remaining amount.**3** Press the **ENTER** key.**About the media residual print**

When [MEDIA RESIDUAL] of the machine setup is "ON" (P.3-16), You can print a list of print the current date and media remaining.

1 In Local, Press **▲▼◀▶**.

- It enters into the origin setting mode.

2 Press the **FUNC3** key.

- Appear the confirmation screen of media remaining print.

3 Press the **ENTER** key.

- Media residual print starts.

Entering media thickness

If the thickness input setting in [MEDIA DETECT] in machine setup is turned "ON" (P.3-16), set the media thickness as follows:

1 Display the screen for entering the media thickness.**2** Press **▲▼** to enter media thickness.**3** Press the **ENTER** key.**Resetting the Media**

If you change the setting of the print area without raising the clamp lever or re-perform the media detection, please perform the following operation.

1 Press the **SEL** key in the local mode, and then press **FUNC2** (MEDIA).**2** Press the **▲▼** key to select the method of resetting the media, and then press **ENTER**.

- Media resetting can be selected from two methods.
 - Width Only
 - Sets only PRINT AREA [WIDTH].
 - All
 - Resets all media sensor information. (Reset the same information as when raising the clamp lever.)



- If media detection is performed using the tension bar, leaf media detection can not be performed even if [Width only] is selected and reset. If you want to detect leaf media, please raise the clamp lever and set media.

3 Press the **ENTER** key.

Print adjustment

After the media is in place, perform a test print to adjust the printer before actual printing starts.



- The printer must be adjusted before actual printing starts.



- This machine allows the media to be aligned to the right edge or centered. When setting up the media, make sure at least one of the two media sensors at the rear of the main unit is covered by the media.

Changing the printing origin

The position of the printing origin can be changed. Moving the LED pointer to the changing position and deciding the position.

- 1 In Local, Press** .
 - It enters into the origin setting mode.

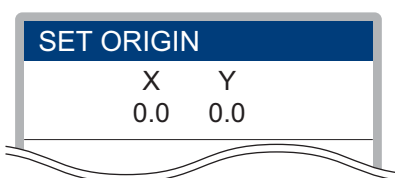

- 2 Press** **to set a light point of the LED pointer to the changing position.**
 - Select the carriage and media, moving the point with [**▲**][**▼**][**◀**][**▶**].

- 3 After determining the origin, press the** **key.**
 - The printing origin is changed.

Test Printing

Print a test pattern to check that there are no discharging defects such as nozzle clogging (slight touching of ink or nozzle missing).

Relationship between head row and test pattern

The relations between head row and test pattern print position are as follow.

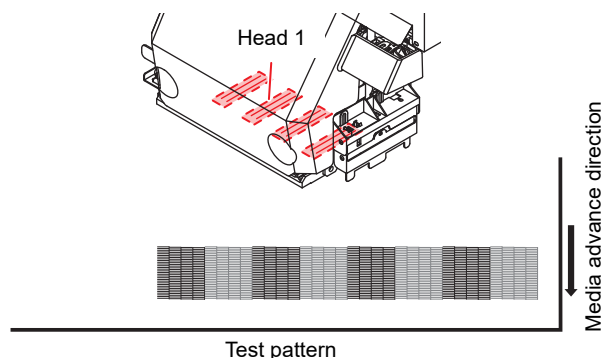

Note on test printing



- When using leaf media, set a media of more than A3 size put horizontally. If a media with narrow width is set, printing will only be conducted to midway.
- When using a roll media, rewind the media by hand before printing so that it is not loose. When the roll media has not been rewound tightly, it may cause image quality to deteriorate.

Test Printing

Print a test pattern to check that there are no discharging defects such as nozzle clogging (slight touching of ink or nozzle missing).

In addition, you can select the orientation of the test pattern to print from two types in order to perform test printing repeatedly. Select one depending on your use.

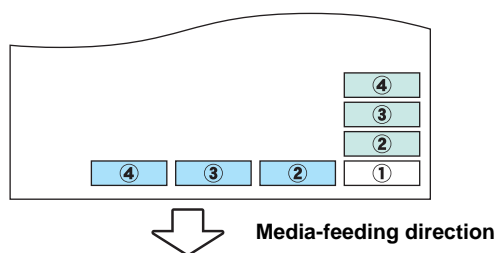

- : When the the test pattern orientation is "FEED DIR."
- : When the the test pattern orientation is "SCAN DIR."

Check before test printing.
• If a media has been set P.2-28
• If the origin position has been set
• If the head gap has been adjusted P.2-8
• If the necessary settings have been configured for nozzle recovery P.4-18

- 1 Press the** **(TEST PRINT/CLEANING), and then press the** **key in LOCAL.**
 - The test pattern orientation screen will be displayed.

- 2 Press** **to select the test pattern orientation (SCAN DIR./ FEED DIR.).**
 - The orientation selected here will be reflected on when you will print next time.
 - When performing test printing after having changed the orientation from "SCAN DIR." to "FEED DIR.", the line is fed to the position of the first test printing.

- 3 Press the** **key.**
 - The NOZZLE RECOVERY setting screen will be displayed.



- If no recovery nozzles are registered in "Nozzle Recovery" in the maintenance menu (P.4-18), or if the test print setting is not set to "ON" (P.4-20), the test print begins. Proceed to step 6.

4 Press to select NOZZLE RECOVERY function ON/OFF.

• The orientation selected here will be reflected on when you will print next time.

ON : Print the pattern of nozzles with recovered nozzles by other nozzles, which have been registered by the nozzle recovery of the maintenance menu.

OFF : Print the pattern without Nozzle Recovery.

5 Press the key.

- Test printing starts.
- When the printing has been completed, the screen returns to LOCAL.

6 Check the printed test pattern.

- When the result is normal, end the operation.
- When the result is abnormal, perform head cleaning. ( P.2-29)

Normal pattern

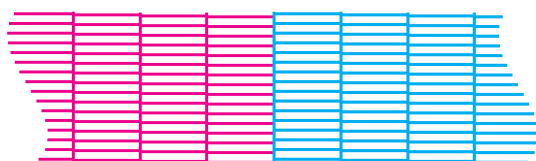

Abnormal pattern

Nozzles are dirty

Clogged with ink

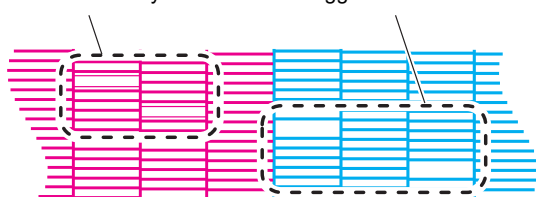

Head Cleaning

About head cleaning

Check the printed test pattern result and perform cleaning depending on the status.

Select one from the three types below:

NORMAL : When any line is missing

SOFT : When only head wiping is needed (when lines are bent)

HARD : When poor image quality cannot be improved even by NORMAL or SOFT cleaning

Perform head cleaning depending on the test printing result

There are three types of head cleaning. Use one by checking the test pattern.

1 Press the (TEST PRINT/CLEANING) key in LOCAL.

- CLEANING MENU will be displayed.

2 Press to select the cleaning type.

- **NORMAL** : Select this if any line is missing.
- **SOFT** : When only head wiping is desirable. (in case of bent lines)
- **HARD** : Select this if inferior printing cannot be improved even by [NORMAL] or [SOFT] cleaning.

3 Press the key.

4 Perform test printing again, and check the result.

- Repeat the cleaning and the test printing until the printing result becomes in normal.



• When the image quality is not improved after the head cleaning.

• Clean the wiper and ink cap. ( P.4-10)

• Wash the head nozzle. ( P.4-12)

Feed settings

Correct the media feed amount to match the type of media you are using.

If the correction value is not appropriate, stripes may appear on the printed image, thus resulting in a poor printing.



- On completion of [MEDIA COMP.] during use of a roll media, the media returns to the printing origin. Then the roll media in the rear of this machine will slacken. Before printing, take up the slack in the roll media by hand; a loose roll media can result in an inferior image quality.
- When printing with a take-up device, set the media first and then perform media correction.

Setting of Media Correction

A pattern for media correction is printed and a media-feeding rate is corrected.



- Two bands are printed in the correction pattern.
- Make adjustment so that an even color density is obtained in the boundary between the two bands.

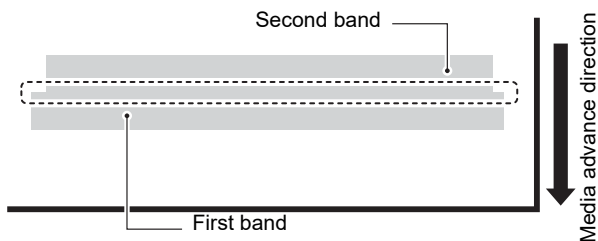

1

Set a media. (☞ P.2-28)

2

Press the **SEL** key, and then press the **FUNC2 (ADJUST)** in LOCAL.

- ADJUST MENU will be displayed.

3

Press the **ENTER** key twice to print the correction pattern

4

Check the correction pattern and enter a correction value.

- A screen for entering the correction value will be displayed.
- **Enter a correction value in "+":**
The boundary between the two bands is widened.
- **Enter a correction value in "-":**
The boundary between the two bands is narrowed.
- When you change the correction value by "30", the width of the boundary changes by about 0.1 mm.

If the Positions of Dots Shift...

When the condition for printing (media thickness/ink type/ etc.) has been changed, perform the following operation to correct the ink drop position for bidirectional (Bi) printing and obtain the proper printing result.



- Dot position correction finely adjusts the nozzles. Pattern printing for checking must always be performed using paper media. Fine patterns cannot be printed on cloth media.
- With the Tx300P-1800, use the adjustment spacer.
- With the Tx300P-1800 MkII, use the platen for paper. If the cloth media was used before, the platens must be swapped. Adjustment spacer attachment (Tx300P-1800 only) (☞ P.2-4)

Adjustment spacer attachment (Tx300P-1800 only)

1

Move the fabric retainers to the left and right.

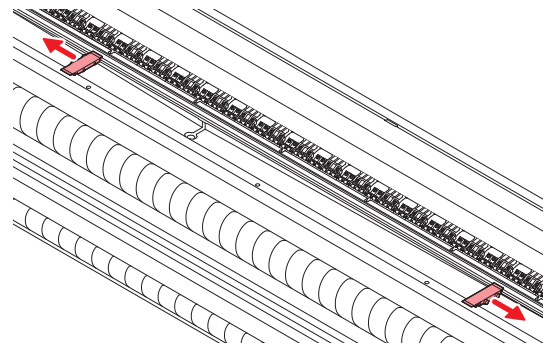

2

Attach the adjustment spacers.

- Place the adjustment spacer with the larger channel at the front.

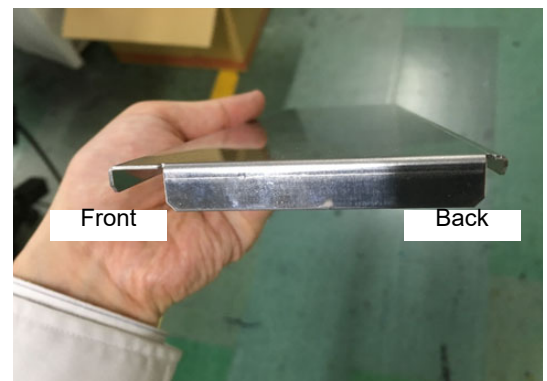
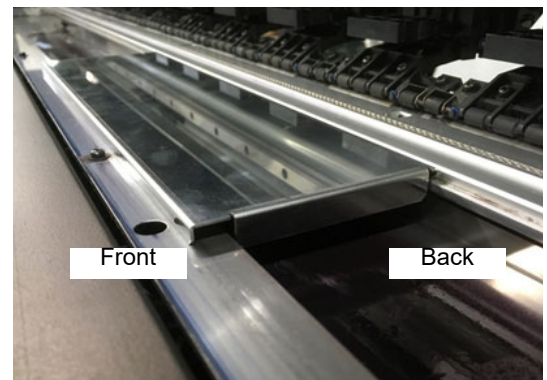

Setting up the media for pattern checking

Use paper leaf media. (P.2-24)

Important!

- When using leaf media, set a media of more than A3 size put horizontally. If a media with narrow width is set, printing will only be conducted to midway.

Example of a Printed Pattern

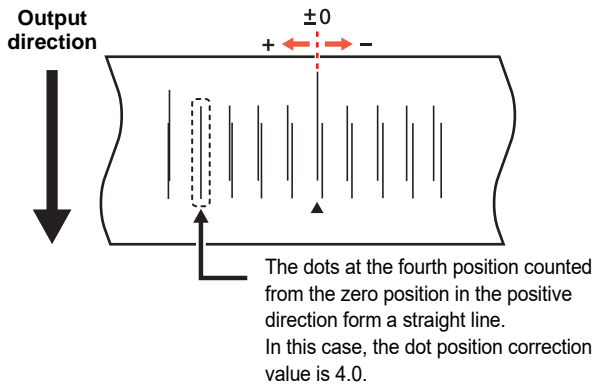

1 Press the **SEL** key, and then press the **FUNC1 (ADJUST)** in LOCAL.

- ADJUST MENU will be displayed.

2 Press **▼**, and then press the **ENTER** key.

- "DROP.POScorrect" will be selected.

3 Press the **ENTER** key.

- Printing of the Drop position correct printed pattern will start.
- Multiple test patterns are printed. (The printed patterns are called Pattern 1, Pattern 2, Pattern 3... in the order of printing.)

Checking pattern print results

Check the pattern print results and adjust, if necessary.

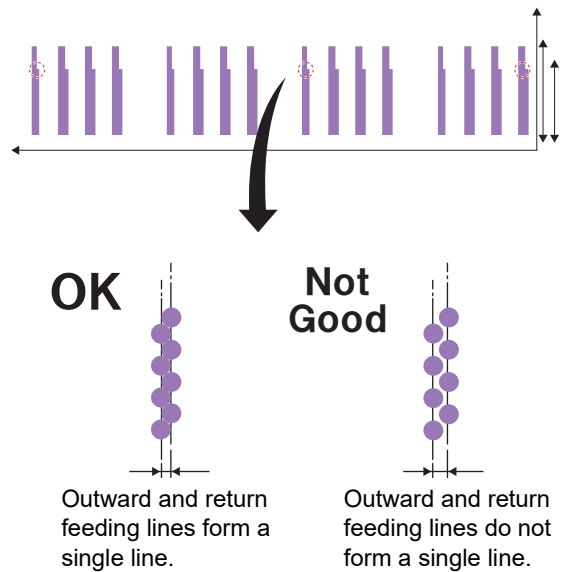

1 Press **▲** **▼** to enter a correction value of Pattern 1, and then press the **ENTER** key.

- Corrected feeding rate: -40 to 40
- Check the test patterns. The position where an outward feeding line and a return feeding line become one straight line is the correction value.
- When the correction value is not between -40 and 40, adjust the height of the printing heads and then perform the operations in Step 2 and later.

2 In the same way as in Step 1, enter a correction value of Pattern 2 and later, and then press the **ENTER** key.

3 Press the **END/POWER** key several times to end the setting.

Adjustment to Refine Finished Printing

If lines appear on the printed results, adjust the feed and take-up units as follows and readjust the media feed rate.



- When you have changed the media type, check the pattern and perform adjustment depending on the status.
- When printing with a take-up device, set the media first and then perform media correction.

Flow of media feeding correction

1

Check that the feed correction setting value is “0”.

Referring to “Feed settings”
(☞ P.2-30).

2

Make the torque of the tension roller biggest.

Referring to “Setting the torque limiter (cloth media)”
(☞ P.2-14).

3

Print the correction pattern.

Referring to “Feed settings”
(☞ P.2-30).

4

Check the pattern and adjust the counter weight of feeding/ take-up tension bar.

Referring to “How to adjust the weight of feeding/ take-up tension-bar (cloth media)”
(☞ P.2-11).

5

If correction by counter weight adjustment is not enough, adjust the torque.

Referring to “Feeding/ Take-up device”
(☞ P.2-9).

6

If correction by counter weight/ torque adjustment is not enough, input the correction value in the feed correction setting.

Referring to “Feed settings”
(☞ P.2-30).

Printing Data

Starting a Printing Operation



- Be sure to set up the media before starting printing.
- Check to confirm that the printer is correctly connected to the PC before starting printing.
- Prepare the printer driver and output software beforehand.



- When using a roll media, rewind the media by hand before printing so that it is not loose. When the roll media has not been rewound tightly, it may cause the image quality to deteriorate.

1

Setting a Media (☞ P.2-33)

2

Press **FUNC3** (REMOTE) in LOCAL.

- The screen changes to REMOTE, and data can be received from the PC.

3

Transmit data to be printed from the PC.

- The status indicator lamp blinks and the printing conditions are displayed.
- For the method of data transmission, see the instruction manual for the output software.

Resolution : 360 /540 /720 /1080 DPI

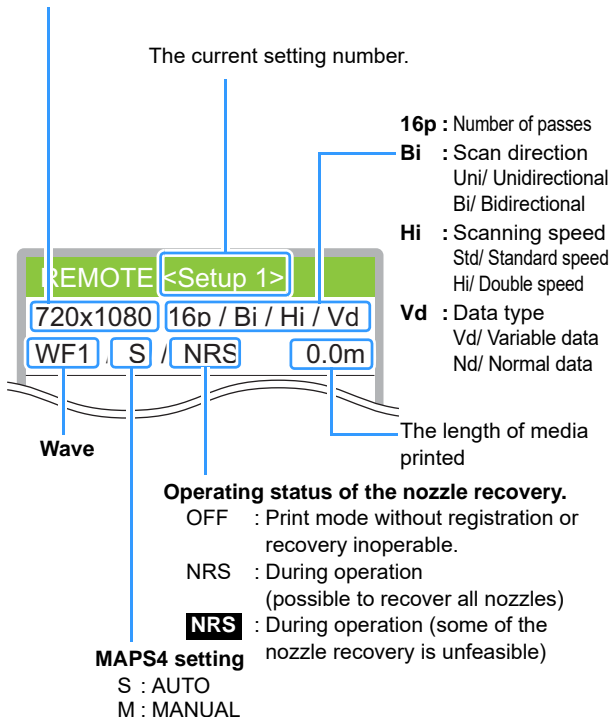

4

Start printing.

- The printing speed may change, depending on the width of the set media or the position of the print origin even when the same data is printed. This is because of a difference in resolution.

Stopping a Printing Operation

Perform the following operation when stopping a printing operation halfway.

1

Press the **FUNC3** (LOCAL) during printing.

- The printing operation stops.
- Interrupt data sending at the PC side during the data is sent from the PC.
- Printing restarts from the interrupted data by repressing the [REMOTE] key.

Deleting Received Data (Data Clear)

When you want to stop printing, delete the already received data.

1

Press the **SEL** key, and then press the **FUNC3** (DATA CLEAR) in LOCAL.

2

Press the **ENTER** key.

- The received data is erased then it returns to the Local.

Behavior after printing has been completed

Drying Feed

If set "DRYING FEED" in the MACHINE SETUP to other than "OFF," after completing the print, it will start the feed operation in order for the print surface to be dried by the external heater.

- Perform the feeding operation until the back edge of printing passes the heater.
- When you press the [END] key, the operation is terminated.
- When the machine has been received next data continuously, it will operate after the last data is received.

Screen display during drying feeding

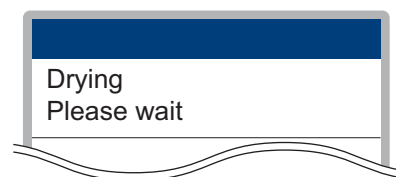

Media replacement

Before replacing the media after printing has ended, remove the old media and set up the new media.

Removal procedure (☞ P.2-34)

Media setting procedure (☞ P.2-16)



- If switching between cloth and transfer paper media, the platen must also be changed. Refer to Main Unit Preparation in this manual. (Tx300P-1800 MkII only)

Media removal

When replacing the media after printing has ended or when replacing the media midway, remove the media as follows:



- Take care to avoid dropping the media on your feet when removing the roll media. The media is heavy and may cause injuries.
- Assign at least two persons to remove the roll media. The weight of the roll media may cause back injuries.



- When setting the new media refer to (☞ P.2-16 "Setting a Media")

Removing the roll media

Remove the media after printing has ended as follows:

Removing media after printing

1

Cut off the media.

- Use scissors or similar implement to cut off the media up to the printed part.



- When using paper media, take care to avoid cutting your hands on the cut edge.

2

Use the take-up unit switch to take up the printed media.

- For more information on how to use the take-up unit, refer to P.2-9 "Feeding/ Take-up device"



- If the same media will continue to be used, reset as follows: (☞ P.2-16)
- If reusing the remaining media when using cloth media, cleanly cut off any loose threads from the cut edge. Loose threads may become caught in the rollers, preventing the media from being fed correctly.

Roll media removal

1

Lift the clamp and take up the roll media on the feed side.

2

Detach the feed side roll holder.

- When using paper media, the tension bar must be moved.

1) Hold the tension bar toward the rear of the main unit.

Feeding side tension bar

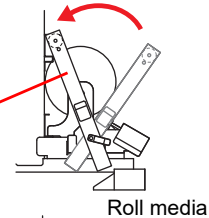

2) Remove the roll media.

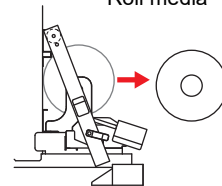

3) Move the tension bar back to its original position.

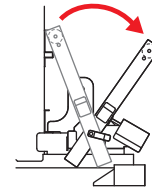

Chapter 3

Setup



This chapter

describes the various setting of this machine.

About SETUP MENU	3-2	Setting a LANGUAGE.....	3-17
SETUP MENU table.....	3-3	Setting Time.....	3-17
Register the optimal print conditions to match the use	3-4	Setting Unit (Temperature/ Length)	3-18
Setting of Media Correction.....	3-5	Setting a KEY BUZZER.....	3-18
If the Positions of Dots Shift.....	3-6	Setting the VIEW FEED.....	3-18
Setting of Logical Seek	3-7	Setting the amount of blank space between printed lines	3-18
Setting of Overprint	3-7	Setting the SPACE FEED MODE.....	3-19
Setting of Drying Time.....	3-7	Set the network.....	3-19
Setting of Left and Right Margins.....	3-8	Setting event mail function.....	3-20
Setting of Vacuum Fan.....	3-8	Initializing the Settings	3-23
Setting of Feed Speed	3-8	About NOZZLE CHECK MENU	3-24
Setting of MAPS4.....	3-9	INFORMATION MENU table	3-24
Setting Auto Cleaning	3-10	Printing Check Flow.....	3-25
Setting Interval wiping	3-11	Printing Operations at “Nozzle Missing” Judgment and Error Occurrence	3-25
Setting External heater.....	3-11	Setting the Printing Check.....	3-26
About MACHINE SETUP MENU	3-12	Setting the NOZZLE RECOVERY	3-26
MACHINE SETUP MENU table	3-13	Setting the Judgement Condition.....	3-26
Setting a AUTO Power-off.....	3-14	About INFORMATION MENU	3-27
Setting Feeding and Take-up unit.....	3-14	INFORMATION MENU table	3-27
Setting Top Blower.....	3-15	Displaying the Information	3-28
Setting the Display of Media Residual	3-16		
Setting the PG Drop Adjust	3-16		
Setting the Media Detection	3-16		
Setting the Drying Feed	3-17		

About SETUP MENU

On SETUP MENU, you can set the print conditions to match the media you usually use.

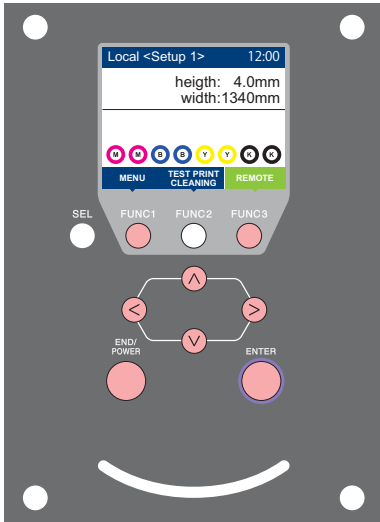

- FUNC1** : Press this to select SETUP MENU, or to switch to the previous screen.
- FUNC3** : Press this to switch to the next screen.
- ▲ ▼** : Use these to select a setting item.
- ENTER** : Press this to confirm a setting, etc..

◆ SETUP MENUs at-a-glance

The following sequence shows the navigation through the SETUP MENU:

- Local <Setup 1>** (12:00) showing height: 4.0mm and width:1340mm. Press **FUNC1** to enter the **MENU** screen.
- MENU** screen with options: SETUP, MAINTENANCE, MACHINE SETUP, NOZZLE CHECK, INFORMATION. Press **ENTER** to select **SETUP**.
- SETUP** screen with options: SETUP 1, SETUP 2, SETUP 3, SETUP 4, Temporary. Select "SETUP 1 to 4" or "Temporary", and then press the **ENTER** key.
- SETUP 1** 1/3 screen with options: FEED COMP., DROP.POScorrect, LOGICAL SEEK HOST, Overprint HOST, DRYING TIME. Press **FUNC3** to go to the next screen.
- SETUP 1** 2/3 screen with options: MARGIN/LEFT HOST, MARGIN/RIGHT HOST, VACUUM HOST, FEED SPEED HOST, AUTO CLEANING. Press **▲ ▼** to navigate.
- SETUP 1** 3/3 screen with options: INTERVAL WIPING, EXTERNAL HEATER OFF, MAPS4, RESET SETTING. Press **▲ ▼** to navigate.

SETUP MENU table



- For each setting item below, you can set it so that the machine may operate according to the value specified when you printed from your RIP software in the connected host PC.
- **Set Item** : LOGICAL SEEK/ Overprint/ DRYING TIME/ MARGIN (LEFT and RIGHT)/ FEED SPEED
- When you operate the machine according to the contents specified with the RIP software, set each item to "Host" when registering this machine type. When you set it other than "Host", the machine operates according to the machine setup.
- For the specifying method with the RIP software, refer to the operation manual of the RIP software.

Function name		Set value	When no instruction from RIP exists ^{*1}	Outline
FEED COMP. (P.3-5)		-9999 to 0 to 9999	_____	Used to print a pattern for correcting a media-feeding rate and correct it.
DROP.POScorrect (P.3-6)		-40.0 to 0 to 40.0	_____	Used to adjust the dot position in go and return printing.
LOGICAL SEEK (P.3-7)		HOST/ ON / OFF	OFF	Sets the scan movable area during printing.
Overprint (P.3-7)		HOST/ 1 to 9	1	Sets the number of layers in which ink is to be applied.
DRYING TIME (P.3-7)	SCAN	HOST/ 0.0 to 9.9 sec	0 sec	Sets the time to wait for ink drying.
	PRINT END	HOST/ 0 to 120 min	0 min	
MARGIN/LEFT (P.3-8)		HOST/ -10 to 85 mm	0 mm	Sets a non-printing area along the right and left edges of the media.
MARGIN/RIGHT (P.3-8)			0 mm	
VACUUM (Tx300P-1800 MkII Only)		OST/ WEAK/ STANDARD/ STRONG	STRONG	Sets the absorbability of the media.
FEED SPEED ^{*2} (P.3-8)		HOST/ 10 to 200%	100%	Changes the media feeding speed in printing.
AUTO CLEANING (P.3-10)	DEFAULT, FILE, LENGTH, TIME		_____	Sets the automatic cleaning operation for the head performed before printing or during printing.
	DEFAULT		The value differs depending on the type of ink to be used and the operating environment.	
	FILE INTERVAL	1 to 1000	_____	
	TYPE	NORMAL/ SOFT/ HARD	_____	
	LENGTH INTERVAL	0.1 to 100.0 m	_____	
	TYPE	NORMAL/ SOFT/ HARD	_____	
	TIME INTERVAL	10 to 480 min	_____	
TYPE	NORMAL/ SOFT/ HARD	_____		
Cleaning Check		ON/ OFF	_____	Set to run or not a nozzle check after auto cleaning.
EXEC.TIMING		END OF FILE/PRINTING	_____	Sets the timing for cleaning operation performed when "LENGTH" or "TIME" is selected.
INTERVAL WIPING (P.3-11)		3 to 255 min, OFF	_____	Sets the wiping operation performed after printing is completed.
EXTERNAL HEATER (P.3-11)		ON/ OFF	_____	Used to set external heater to ON/OFF
MAPS4 (P.3-9)	AUTO			Perform setting to reduce stripes between passes.
	MANUAL	SPEED	50 to 100%	
		Smoothing Lv.	0 to 25 to 100%	
RESET SETTING (P.3-5)		The configuration in the settings 1-4 can be reset individually.		

*1. This is the setting value to be used for printing when setting value is not specified at the RIP software (host) side, or, you give priority to the setting value at the machine side.

*2. When you set this to "100%" or more, required time for completion of printing will be shortened. However, enough drying time cannot be ensured and it may affect the image quality.

Register the optimal print conditions to match the use

In this machine, you will be able to register print conditions, SETUP 1 to 4 individually to match the media in advance.

For example, after print on different types of media, return to the media always use. In such case you can set the optimum printing conditions by simply selecting the registered SETUP 1 to 4.



- Print conditions that can be pre-registered with the machine are the four types, "SETUP 1" to "SETUP 4".
- If you print with the print condition which do not often use, you will be able to set the print conditions by selecting "Temporary". If turn on the power again, settings in "Temporary" will return to the original state when it was purchased. Also if turn on the power again in "Temporary" state, it will be the state in selecting "SETUP 1".

Register the print conditions to SETUP 1 to 4

1 Press **FUNC1 (MENU)** → **ENTER** in LOCAL.

2 Press **▲▼** to select SETUP 1 to 4, and press the **ENTER** key.

- The item selected indicates ● and others show ○.
- SETUP MENU will be displayed.

3 Press **▲▼** to select and set each item in the setup menu list.

- Please see the reference page in the setup menu list for detailed configuration procedure.

How to use [Temporary]

[Temporary] is not only to set the print condition to be used only once, but also can be used for partial change of the registered SETUP "1 to 4", or for reflecting the print conditions set by the [Temporary] to SETUP 1 to 4.

● Register the print conditions in [Temporary]

Registration of the print conditions to [Temporary] can be done as the same method as to SETUP 1 to 4.

1 Press **FUNC1 (MENU)** → **ENTER** in LOCAL.

2 Press **▲▼** to select "Temporary", and press the **ENTER** key.

- SETUP MENU will be displayed.

3 Press **▲▼** to select and set each item in the setup menu list.

- Please see the reference page in the setup menu list for detailed configuration procedure.

● Copy the contents of SETUP 1 to 4 to [Temporary]

You can use it with changing the part of registration contents of SETUP 1 to 4.

Select "copy" from the registration screen of [Temporary], and specify the copy source (SETUP 1 to 4).

1 Press **FUNC1 (MENU)** → **ENTER** in LOCAL.

2 Press **▲▼** to select "Temporary", and press the **ENTER** key.

- SETUP MENU will be displayed.

3 Press **FUNC1 (<<)**.

4 Press **▲▼** to select "COPY", and press the **ENTER** key.

- Selection screen of the copy source will be displayed.

5 Press **▲▼** to SELECT the copy source (SETUP 1 to 4) and press the **ENTER** key.

- Confirmation screen of the copy will be displayed.

6 Press the **ENTER** key.

- Settings selected in step 5 is copied to Temporary.

7 Press **▲▼** to select the setting item to be changed, and press the **ENTER** key.

- Please see the reference page in the setup menu list for detailed configuration procedure.

● Reflect The Content Set In [Temporary] To Setup 1 To 4

1 Press **FUNC1 (MENU)** → **ENTER** in LOCAL.

2 Press **▲▼** to select "Temporary", and press the **ENTER** key.

- SETUP MENU will be displayed.

3 Press **▲▼** to select and set each item in the setup menu list.

- Please see the reference page in the setup menu list for detailed configuration procedure.

4 Display the last page of Temporary and select "SAVE SETTING", and press the **ENTER** key.

- Selection screen of the save location will be displayed.

5 Press **▲▼** to select the location selected (SETUP 1 to 4), and press the **ENTER** key.

- Save confirmation screen will be displayed.

- 6** Press the **ENTER** key.
- Settings of Temporary will be saved to the location selected in step 5.

- 7** Press the **END/POWER** key several times to end the setting.

Reset the registered contents

Reset the contents registered to SETUP 1 to 4.

- 1** Press **FUNC1 (MENU)** → **ENTER** in LOCAL.

- 2** Press **▲▼** to select **SETUP 1 to 4** to be reset and press the **ENTER** key.
- SETUP MENU will be displayed.

- 3** Press **FUNC1 (<<)**.

- 4** Press **▲▼** to select **"RESET SETTING"**, and press the **ENTER** key.
- Confirmation screen of reset settings will be displayed.

- 5** Press the **END/POWER** key several times to end the setting.

Setting of Media Correction

Correct the media feed amount to match the type of media you are using.

If the correction value is not appropriate, stripes may appear on the printed image, thus resulting in a poor printing.

Important!

- On completion of [MEDIA COMP.] during use of a roll media, the media returns to the printing origin. Then the roll media in the rear of this machine will slacken. Before printing, take up the slack in the roll media by hand; a loose roll media can result in an inferior image quality.
- When printing with a take-up device, set the media first and then perform media correction.

A pattern for media correction is printed and a media-feeding rate is corrected.



- Two bands are printed in the correction pattern.
- Make adjustment so that an even color density is obtained in the boundary between the two bands.

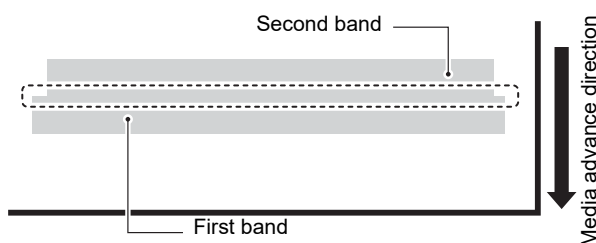

- 1** Set a media. (☞ P.2-16)

- 2** Press **FUNC1 (MENU)** → **ENTER** in LOCAL.

- 3** Press **▲▼** to select **SETUP 1 to 4**, and press the **ENTER** key.
- SETUP MENU will be displayed.

- 4** Press **▲▼** to select **"FEED COMP"**, and press the **ENTER** key.

- 5** Press the **ENTER** key twice to print a correction pattern.

- 6** Check the correction pattern and enter a correction value.

- A screen for entering the correction value will be displayed.
- **Enter a correction value in "+":**
The boundary between the two bands is widened.
- **Enter a correction value in "-":**
The boundary between the two bands is narrowed.
- When you change the correction value by "30", the width of the boundary changes by about 0.1 mm.

- 7** Press the **ENTER** key.

- Print a correction pattern again and check it.
- When media correction is needed, perform the operation in Step 7 to make correction.

- 8** Press the **END/POWER** key several times to end the setting.

Correcting Media-feeding during Printing

A media-feeding rate can be corrected even in the remote mode or when image data is printed.

- 1** Press **FUNC1** (ADJUST) → **ENTER** in the Remote.
- 2** Press **▲** **▼** to enter a corrected feeding rate.
 - Corrected feeding rate: -9999 to 9999
 - The value entered here is reflected in the corrected feeding rate soon.
- 3** Press the **ENTER** key twice .
 - key. The changed value is registered.
 - When you press the [ENTER] key instead of the [END] key, the value entered here will be valid temporarily. (When you perform media detection again or turn the power OFF, the correction value is cleared.)

If the Positions of Dots Shift...

When the condition for printing (media thickness/ink type/ etc.) has been changed, perform the following operation to correct the ink drop position for bidirectional (Bi) printing and obtain the proper printing result.

Example of a Printed Pattern

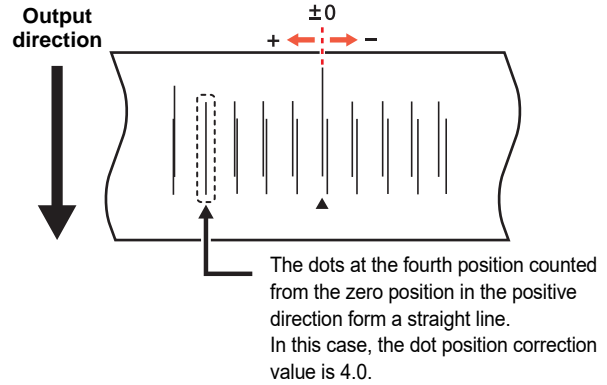

- 1** Set a media on the machine. (P.2-16)
 - In order to print a pattern, a media that is 500 mm wide at least is necessary.
- 2** Press **FUNC1** (MENU) → **ENTER** in LOCAL.
- 3** Press **▲** **▼** to select **SETUP 1 to 4**, and press the **ENTER** key.
 - SETUP MENU will be displayed.
- 4** Press **▲** **▼** to select “**DROP.POS correct**”, and press the **ENTER** key.
- 5** Press the **ENTER** key.
 - Start the pattern printing.
 - Multiple test patterns are printed. (The printed patterns are called Pattern 1, Pattern 2, Pattern 3... in the order of printing.)
- 6** Press **▲** **▼** to enter a correction value of **Pattern 1**, and press the **ENTER** key.
 - Corrected feeding rate: -40 to 40
 - Check the test patterns. The position where an outward feeding line and a return feeding line become one straight line is the correction value.
 - When the correction value is not between -40 and 40, adjust the height of the printing heads and then perform the operations in Step 2 and later.
- 7** In the same way as in Step 4, enter a correction value of **Pattern 2** and later, and press the **ENTER** key.
- 8** Press the **END/POWER** key several times to end the setting.

Setting of Logical Seek

The head's operation varies depending on the LOGICAL SEEK settings, as shown in the figure below.

Movement of heads when LOGICAL seek is OFF

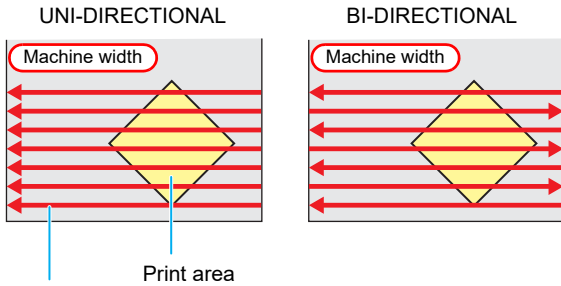

Red arrow :
Movement of head

Movement of heads when LOGICAL seek is ON

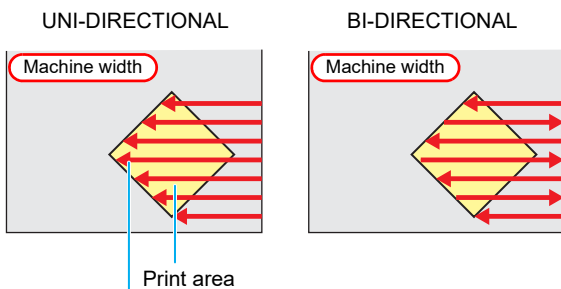

Red arrow :
Movement of head

1 Press **[FUNC1] (MENU)** → **[ENTER]** in LOCAL.

2 Press **[▲]** **[▼]** to select **SETUP 1 to 4**, and press the **[ENTER]** key.

• SETUP MENU will be displayed.

3 Press **[▲]** **[▼]** to select **“LOGICAL SEEK”**, and press the **[ENTER]** key.

4 Press **[▲]** **[▼]** to select a set value, and press the **[ENTER]** key.

• Set value : HOST / ON / OFF

5 Press the **[END/POWER]** key several times to end the setting.

Setting of Overprint

Sets the number of layers in which ink is to be applied.

1 Press **[FUNC1] (MENU)** → **[ENTER]** in LOCAL.

2 Press **[▲]** **[▼]** to select **SETUP 1 to 4**, and press the **[ENTER]** key.

• SETUP MENU will be displayed.

3 Press **[▲]** **[▼]** to select **“Overprint”**, and press the **[ENTER]** key.

4 Press **[▲]** **[▼]** to set number of Overprint, and press the **[ENTER]** key.

• Setting value : Host/ 1 to 9 times

5 Press the **[END/POWER]** key several times to end the setting.

Setting of Drying Time

In the drying time setting, the following items for ink drying time are set.

- **SCAN** : Ink drying time for each scanning is set. (During bidirectional printing, the machine stops for a certain period of time specified for each of the outward and return scanning.)
- **PRINT END** : Ink drying time after printing has been complete is set.

Important!

- When you give priority to the setting at the RasterLink side, make the setting value “Host”.
- “SCAN” set in this machine is displayed as “Pause Time per Scan” in the RasterLink.
- You cannot specify the print end at the RasterLink side. When you set this machine to “Host”, printing will be performed in “PRINT END= 0 min.” status.

1 Press **[FUNC1] (MENU)** → **[ENTER]** in LOCAL.

2 Press **[▲]** **[▼]** to select **SETUP 1 to 4**, and press the **[ENTER]** key.

• SETUP MENU will be displayed.

3 Press **[▲]** **[▼]** to select **“DRYING TIME”**, and press the **[ENTER]** key.

4 Press the **[ENTER]** key.

5 Press **[▲]** **[▼]** **[◀]** **[▶]** to set drying time, and press the **[ENTER]** key.

- Set the drying time for canning and after printing is completed. To enable the drying time specified in your RIP, select “Host”.
- **Scanning setting value** : Host or 0.0 sec. to 9.9 sec.
- **Print end setting value** : Host or 0 sec. to 120 minutes.
- **Item selecting** : by the **[▲]** **[▼]** keys
- **Time setting** : by the **[◀]** **[▶]** keys

6 Press the **[END/POWER]** key several times to end the setting.

Setting of Left and Right Margins

Set a non-printing area along the left and right edges of the media.

The offset value against the standard margin 20 mm is set hereupon.



- When you give priority to the setting at the RIP software side, make the setting value "Host".
- You cannot specify the margins at the attached RIP software (RasterLink). When you use the RasterLink, if you set this machine to "Host", printing will be performed in "Margins for right and left off set value= 0 mm" status.
- The margin setting is reflected when the media width is detected.

- 1 Press **FUNC1 (MENU)** → **ENTER** in LOCAL.
- 2 Press **▲▼** to select **SETUP 1 to 4**, and press the **ENTER** key.
 - SETUP MENU will be displayed.
- 3 Press **FUNC3 (>>)**.
- 4 Press **▲▼** to select "Margin/L" or "Margin/R", and press the **ENTER** key.
- 5 Press **▲▼** to select a set value, and press the **ENTER** key.
 - Set value : HOST / -10 to 85 mm
- 6 Press the **END/POWER** key several times to end the setting.



- Pay attention to that printing may start on the media press if a right and left margin is set to 5 mm or less when the media press is used in printing.

Setting of Vacuum Fan

Sets the absorbability of the media.

By setting the absorption power to match the media, you can prevent print errors due to media rise-up

- 1 Press **FUNC1 (MENU)** → **ENTER** in LOCAL.
- 2 Press **▲▼** to select **SETUP 1 to 4**, and press the **ENTER** key.
 - SETUP MENU will be displayed.
- 3 Press **FUNC1 (<<)**.
- 4 Press **▲▼** to select "VACUUM FAN", and press the **ENTER** key.
- 5 Press **▲▼** to select a set value, and press the **ENTER** key.
 - Set value : HOST/ WEAK / STANDARD / STRONG
- 6 Press the **END/POWER** key several times to end the setting.

Setting of Feed Speed

Changes the media feeding speed in printing.

- 1 Press **FUNC1 (MENU)** → **ENTER** in LOCAL.
- 2 Press **▲▼** to select **SETUP 1 to 4**, and press the **ENTER** key.
 - SETUP MENU will be displayed.
- 3 Press **FUNC1 (<<)**.
- 4 Press **▲▼** to select "FEED SPEED", and press the **ENTER** key.
- 5 Press the **ENTER** key.
- 6 Press **▲▼** to select a set value, and press the **ENTER** key.
 - Set value : HOST / 10 to 200%
- 7 Press the **END/POWER** key several times to end the setting.

Setting of MAPS4

The MAPS (Mimaki Advanced PassSystem) function to disperse the pass boundary to make the feeding stripes less visible.



- MAPS4 provides two setting options: "AUTO" and "MANUAL". Select "AUTO" or "MANUAL" according to your usage.



- Changing the MAPS4 settings may change the color tone. Check the effects before use.
- MAPS may not be effective depending on image to be printed. Use it after checking effect in advance.

● Conditions disabling MAPS function

The MAPS function may be disabled under the following conditions. In addition, the MAPS may not be effective, depending on the image to be printed.

Sb420 ink 4-colors ink set / Sb421 ink 4-colors ink set

Resolution	Pass	Scan speed
540 x 360	2 pass	High speed
720 x 720	4 pass	
720 x 1080	6 pass	
720 x 1440	8 pass	

Rc400 ink 8-colors ink set

Resolution	Pass	Scan speed
720 x 1080	12 pass	High speed
720 x 1440	16 pass	

Ac400 ink 8-colors ink set

Resolution	Pass	Scan speed
720 x 1440	16 pass	High speed

Sb420 ink 6-colors ink set / Sb421 ink 6-colors ink set / Dd400 ink 8-colors ink set

Resolution	Pass	Scan speed
540 x 360	4 pass	High speed
720 x 720	8 pass	
720 x 1080	12 pass	
720 x 1440	16 pass	

Rc500 ink 8-colors ink set

Resolution	Pass	Scan speed
720 x 1080	12 pass	High speed

Sb420 at the ink set of Sb420+TP400 4 + 4colors / Sb421 at the ink set of Sb421+TP400 4 + 4colors / Sb411 at the ink set of Sb411+TP400 4 + 4colors / Sb411 & Sb420 at the ink set of Sb411+Sb420 4 + 4colors

Resolution	Pass	Scan speed
540 x 360	4 pass	High speed
720 x 720	8 pass	
720 x 1080	12 pass	
720 x 1440	16 pass	

Setting MAPS4 Function (AUTO)

- 1 Press **FUNC1** (MENU) → **ENTER** in LOCAL.
- 2 Press **▲** **▼** to select SETUP 1 to 4, and press the **ENTER** key.
 - SETUP MENU will be displayed.
- 3 Press **FUNC1** (<<).
- 4 Press **▲** **▼** to select "MAPS4", and press the **ENTER** key.
- 5 Press **▲** **▼** to select "AUTO", and press the **ENTER** key.
 - To select "MANUAL" for the setting, refer to P.3-9 "Setting MAPS4 Function (MANUAL)".
- 6 Press the **END/POWER** key several times to end the setting.

Setting MAPS4 Function (MANUAL)

- 1 Press **FUNC1** (MENU) → **ENTER** in LOCAL.
- 2 Press **▲** **▼** to select SETUP 1 to 4, and press the **ENTER** key.
 - SETUP MENU will be displayed.
- 3 Press **FUNC1** (<<).
- 4 Press **▲** **▼** to select "MAPS4", and press the **ENTER** key.
- 5 Press **▲** **▼** to select "MANUAL", and press the **ENTER** key.
 - To select "AUTO" for the setting, refer to P.3-9 "Setting MAPS4 Function (AUTO)".
- 6 Press **▲** **▼** to select the "SPEED" (50 to 100%), and press the **ENTER** key.
 - Select a speed for printing. By using standard quality printing as reference, set in the direction of minus (-) to decrease the print speed, and set in the direction of plus (+) to increase the print speed.
 - If the speed is changed, NOZZLE RECOVERY (☞ P.3-26) may not become effective. Check in advance before use.
- 7 Press **▲** **▼** to select the "Smoothing Lv.", and press the **ENTER** key.
- 8 Press **▲** **▼** to change the smoothing level, and press the **ENTER** key.
 - Set Value : 0 to 100% (set in units of 5%)
 - The MAPS4 effect become strong as the set value increase, and become weak as the set value decrease.
- 9 Press the **END/POWER** key several times to end the setting.
 - There is a set value that does not change the speed depending on the printing conditions.

Setting Auto Cleaning

You can set the machine so that it counts the number of printed files or the length or time after printing has been completed, and performs cleaning automatically if required. You can select the auto cleaning setting from four types below:

- **DEFAULT** : The cleaning operation units and intervals differ depending on the type of ink to be used or the operating environment. Refer to the table below for more information.
- **PAGE** : Set the cleaning intervals by the number of printed files.
- **LENGTH** : Set the cleaning intervals by the printed length.
- **TIME** : Set the cleaning intervals by the printed time.

● Conditions for Cleaning in "DEFAULT" Mode

The conditions for cleaning differ depending on the type of ink to be used and the operating environment as indicated in the table below.

Ink type	Operation Units	Operating Environment			Operation Timing	Cleaning Type
		Up to 30°C	30 to 35°C	35°C or higher		
Sb420	LENGTH	—	30 m	10 m	PRINTING	Normal
Sb421	LENGTH	—	30 m	10 m	PRINTING	Normal
Dd400	LENGTH	—	—	30 m	PRINTING	Normal
TP400	TIME	480 min	120 min	60 min	END OF FILE	Normal
Rc400	LENGTH	—	50 m	30 m	PRINTING	Soft
Ac400	LENGTH	—	50 m	30 m	PRINTING	Normal
Rc500	LENGTH	—	50 m	30 m	PRINTING	Soft
Sb420+TP400	TIME	480 min	120 min	60 min	END OF FILE	Normal
Sb421+TP400	TIME	480 min	120 min	60 min	END OF FILE	Normal
Sb411+TP400	TIME	480 min	120 min	60 min	END OF FILE	Normal
Sb411+Sb420	LENGTH	—	30 m	10 m	PRINTING	Normal

Important!

- The "-" mark in the table indicates that the auto-cleaning operation is not carried out.
- Even if you select a configuration other than "DEFAULT", the cleaning operation is carried out automatically once the interval set with the conditions specified in the table above is exceeded.
- With hybrid printing, ink is consumed for periodic cleaning even for heads that are not in use.

The functions listed below are also available.

- **Cleaning Check function**
Automatic nozzle check after auto cleaning can be set.
 - **Select Cleaning Operation Timing function**
The cleaning operation timing can be set when "LENGTH" or "TIME" is selected as the unit for cleaning.
- The machine can perform a stable printing operation with its heads always kept clean.

1 Press **FUNC1 (MENU)** **ENTER** in LOCAL.

2 Press **▲▼** to select **SETUP 1 to 4**, and press the **ENTER** key.

- SETUP MENU will be displayed.

3 Press **FUNC3 (>>)**.

4 Press **▲▼** to select "**AUTO CLEANING**", and press the **ENTER** key.

5 Press the **ENTER** key, and press **▲▼** to select the type of auto cleaning.

- There are "DEFAULT", "PAGE", "LENGTH" and "TIME" for auto cleaning.

DEFAULT : When the set cleaning timing has been reached, the machine performs head cleaning automatically.

FILE : When the set number of prints has been completed, the machine performs head cleaning automatically.

LENGTH : When the set length has passed, the machine performs head cleaning automatically.

TIME : When the set time has passed, the machine performs head cleaning automatically.

- If you have selected "DEFAULT", proceed to Step 8.

6 Press **ENTER**, and press **▲▼** to select the cleaning interval.

- Depending on the auto cleaning type selected in the Step 3, the setting value differs.

For FILE : 1 to 1000 file

For LENGTH : 0.1 to 100.0 m (in 0.1 m increment)

For TIME : 10 to 480 min (in 10 min increment)

7 Press the **ENTER** key, and press **▲▼** to select the cleaning type.

- Set Value : NORMAL/ SOFT/HARD

8 Press the **ENTER** key, and press **▲▼** to select "Cleaning Check".

9 Press the **ENTER** key, and press **▲▼** to select set value.

- Set Value : ON/ OFF
- If you have selected "FILE" at step 5, proceed to Step 12.

10 Press the **ENTER** key, and press **▲▼** to select "EXEC.TIMING".

11 Press the **ENTER** key, and press **▲▼** to select set value.

- There are "END OF FILE" and "PRINTING" for set values.

END OF FILE : Carries out the cleaning operations between files after the cleaning interval configured under "LENGTH" or "TIME" in Step 6 has passed.

PRINTING : Stops printing and starts the cleaning operation immediately after the cleaning interval configured under "LENGTH" or "TIME" in Step 6 has passed.

12 Press the **ENTER** key .

13 Press the **END/POWER** key several times to end the setting.

Important!

- Depending on the state of the heads, etc., the image quality deterioration may not be improved even with this function performed. In this case, contact our service office or the distributor in your region.

Setting Interval wiping

When the set time has passed, nozzle face of the head is cleaned automatically to remove ink droplets on the nozzle face.

In case that deflection, nozzle missing, or symptom which ink droplets fall down occurred, set the interval between each operation shorter.

1 Press **FUNC1 (MENU)** → **ENTER** in LOCAL.

2 Press **▲▼** to select **SETUP 1 to 4**, and press the **ENTER** key.
• SETUP MENU will be displayed.

3 Press **FUNC1 (<<)** .

4 Press **▲▼** to select **“INTERVAL WIPING”**, and press the **ENTER** key.

5 Press **▲▼** to set intervals.
• Set Value : 3 to 255 Minutes, OFF
• When [OFF] is set, periodical wiping is not executed.

6 Press the **ENTER** key.

7 Press the **END/POWER** key several times to end the setting.

Setting External heater

Used to set external heater to ON/OFF.

1 Press **FUNC1 (MENU)** → **ENTER** in LOCAL.

2 Press **▲▼** to select **SETUP 1 to 4**, and press the **ENTER** key.
• SETUP MENU will be displayed.

3 Press **FUNC1 (<<)** .

4 Press **▲▼** to select **“EXTERNAL HEATER”**, and press the **ENTER** key.

5 Press **▲▼** to select set value.
• Set Value: ON/OFF

6 Press the **ENTER** key.

7 Press the **END/POWER** key several times to end the setting.

About MACHINE SETUP MENU

Common settings are functions for using this machine easily.
The following items can be set in machine setups.

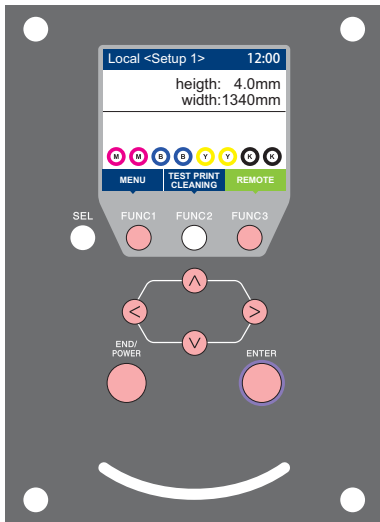

(FUNC1) : Press this to select MACHINE SETUP MENU, or to switch to the previous screen.

(FUNC3) : Press this to switch to the next screen.

(↑) (↓) : Use these to select a setting item.

(ENTER) : Press this to confirm a setting, etc..

◆ MACHINE SETUP MENUS at-a-glance

The following table summarizes the navigation steps shown in the 'at-a-glance' section:

Step	Screen / Item	Action / Label
1	Local <Setup 1>	Press FUNC1
2	MENU	Press ENTER
3	MACHINE SETUP	Press FUNC1
4	MACHINE SETUP 1/4	Press FUNC1
5	MACHINE SETUP 1/4	Press ↑
6	MACHINE SETUP 1/4	Press ↓
7	MACHINE SETUP 1/4	Press FUNC3
8	MACHINE SETUP 2/4	Press FUNC1
9	MACHINE SETUP 2/4	Press ↑
10	MACHINE SETUP 2/4	Press ↓
11	MACHINE SETUP 2/4	Press FUNC3
12	MACHINE SETUP 3/4	Press FUNC1
13	MACHINE SETUP 3/4	Press ↑
14	MACHINE SETUP 3/4	Press ↓
15	MACHINE SETUP 3/4	Press FUNC3
16	MACHINE SETUP 4/4	Press FUNC1
17	MACHINE SETUP 4/4	Press ↑
18	MACHINE SETUP 4/4	Press ↓
19	MACHINE SETUP 4/4	Press FUNC3

MACHINE SETUP MENU table

Function name		Set value	Default	Meaning
AUTO Power-off (☞ P.3-14)		NONE/ 10 ~ 600 min	30 min	When no operation has been performed for the set time, the power supply is automatically turned "OFF".
FEEDING/ TAKE-UP UNIT (☞ P.3-14)	FEEDING UNIT	ON/ OFF	ON	Set whether to use or not to use feeding unit.
	FEEDING TENSION BAR	ON/ OFF	OFF	Set whether to use or not to use feeding tension bar.
	TAKE-UP UNIT	ON/ OFF	ON	Set whether to use or not to use take-up unit.
	TAKE-UP TENSION BAR	ON/ OFF	OFF	Set whether to use or not to use take-up tension bar.
	FEEDING/ TAKE-UP SW	Continuance/ Temporary	Continuance	Set how to operate when the ON/OFF switch for feeding/take-up device is pressed.
Top blower (☞ P.3-15)	ON	AUTO/ STRONG/ WEAK	AUTO	Set the operation of the top blower in print.
	OFF			
MEDIA REMAIN (☞ P.3-16)		ON/ OFF	OFF	You can control the remaining amount of media.
HEAD HEIGHT (☞ P.2-8)		2.0 to 7.0 mm		Set the head height.
PG DROP ADJUST (☞ P.3-16)				Adjust the outward and return ink drop positions during bidirectional printing.
MEDIA DETECT (☞ P.3-17)	DETECTION TYPE	AUTO/MANUAL	AUTO	Set the media detection method.
	INPUT THICKNESS	ON/ OFF	ON	Set whether to enter the thickness of the media to be used during media detection.
	DIA.DETECT	AUTO/MANUAL	AUTO	Sets the detection method of the media outer diameter of the take-up unit and feeding unit.
DRYING FEED (☞ P.3-17)	DRYING FEED	OFF/ 100 to 1,000mm	OFF	Set the length of the media to feed after printing is complete.
LANGUAGE (☞ P.3-17)			English	Displayed language is changed.
TIME (☞ P.3-17)		+4 h ~ -20 h	Japan time	Time difference is corrected.
UNIT/ TEMP. (☞ P.3-18)		°C (Centigrade)/°F (Fahrenheit)	°C	A unit for displaying temperature is set.
UNIT/ LENGTH (☞ P.3-18)		mm / inch	mm	A unit for displaying length and area is set.
KEY BUZZER (☞ P.3-18)		OFF / ON	ON	A buzzer sound when keys are pressed is set.
VIEW FEED (☞ P.3-18)		ON / OFF	ON	Set whether media feeding is performed for checking the result of the test printing etc. or not.
Space Btwn PP. (☞ P.3-18)		None/ 10 to 500 mm	None	Sets the amount of blank space between printed lines.
SPACE FEED MODE (☞ P.3-18)		INTERMITTENT / CONTINUOUS	INTERMITTENT	Change the feed mode of the margin included in the image data.
NETWORK (☞ P.3-19)	Set the network.			
	Check IP Addr.	The IP address currently used by this machine is displayed.		
	Check MAC Addr.	The IP address currently used by this machine is displayed.		
	DHCP	ON / OFF		When it is ON, the IP address given by the DHCP server is used.
	AutoIP	ON / OFF		When it is ON, the IP address is determined by the AutoIP protocol. However, DHCP is ON, DHCP has priority.
	IP Address *1	Set the IP address used by this machine.		
	Default Gateway *1	Set the default gateway used by this machine.		
	DNS Address *1	Set the DNS server address used by this machine.		
	SubNet Mask *1	Set the digit number of the subnet mask used by this machine.		

Function name		Set value		Default	Meaning	
EVENT MAIL	Mail Delivery (☞ P.3-20)	ON / OFF		OFF	Set whether you send/ do not send the e-mail when the set event occurs.	
	Select Event (☞ P.3-20)	Print Start Event	ON / OFF	OFF	Set whether you send/ do not send the e-mail at the start of printing.	
		Print End Event	ON / OFF	OFF	Set whether you send/ do not send the e-mail at the end of printing.	
		Error Event	ON / OFF	OFF	Set whether you send/ do not send the e-mail when a error occurs.	
		Warning Event	ON / OFF	OFF	Set whether you send/ do not send the e-mail when a warning occurs.	
		Other Event	ON / OFF	OFF	Set whether you send/ do not send the e-mail when an event other than the above occurs.	
	Mail Address (☞ P.3-20)	Set the e-mail address to which you send the event mail.		Alphanumeric characters and symbols (within 96 characters)		
	Message Subject (☞ P.3-21)	Set the characters to write in the subject of the event mail.		Alphanumeric characters and symbols (within 8 characters)		
	Server Setup (☞ P.3-21)	SMTP Address		Set the SMTP server.		
		SMTP Port No.		Set the SMTP port number.		
		SENDER ADDRESS		Set the e-mail address to be used as the sender mail address.		
		Authentication	POP before SMTP	Set the SMTP server authentication method (SMTP authentication).		
			SMTP Authentication			
			OFF			
		User Name *2		Set the user name used for the authentication.		
Pass Word *2		Set the password used for the authentication.				
POP3 Address *3		Set the POP server.				
APOP *3		Set ON/ OFF of APOP.				
Transmit Test (☞ P.3-22)	Send the test e-mail.					
RESET(☞ P.3-23)				All setting values are returned to the status default.		

*1. Settable when both of DHCP and AutoIP are [OFF]

*2. Settable only when Auth. is not OFF

*3. Settable only when Auth. is POP before SMTP

Setting a AUTO Power-off

When no operation has been performed for the set time, the power supply is automatically turned "OFF".

- 1 Press **FUNC1 (MENU)** → **▼** (twice) → **ENTER** in LOCAL.
• MACHINE SETUP MENU will be displayed.
- 2 Press **▲▼** to select "AUTO POWER OFF", and press the **ENTER** key.
- 3 Press **▲▼** to select a set value, and press the **ENTER** key.
• Set Value : none, 10 to 600 min
- 4 Press the **END/POWER** key several times to end the setting.

Setting Feeding and Take-up unit

For the "Feeding and Take-up unit" settings, set the following items:

- Use feeding unit and take-up unit/ Do not use feeding unit or take-up unit.
- Use/Do not use tension bar.
- Operation when the ON/OFF switch for feeding/ take-up unit is pressed.

In this machine, by selecting how to use the tension bar in the feeding/take-up unit setting, you can print by any of the following four methods.

Tension bar	How to set the media
Use feeding and take-up tension bar	Set the media refer to P.2-16.
Use on the feeding side only	In P.2-16 "Using the tension bar", configure the settings by excluding all the operations for the tension bar on the unused side.
Use on the take-up side only	
Do not use tension bar	Set the media refer to P.2-21.

- 1 Press **FUNC1 (MENU)** → **▼** (twice) → **ENTER** in LOCAL.
• MACHINE SETUP MENU will be displayed.
- 2 Press **▲▼** to select “FEEDING/TAKE-UP UNIT”, and press the **ENTER** key.
- 3 Press the **ENTER** key.
• “FEEDING UNIT” will be selected.
- 4 Press **▲▼** to select a set value, and press the **ENTER** key.
• Set Value : ON/ OFF
- 5 Press **▼**, and press the **ENTER** key.
• “FEEDING TENSION BAR” will be selected.
- 6 Press **▲▼** to select a set value, and press the **ENTER** key.
• Set Value : ON/ OFF
- 7 Press **▼**, and press the **ENTER** key.
• “TAKE-UP UNIT” will be selected.
- 8 Press **▲▼** to select a set value, and press the **ENTER** key.
• Set Value : ON/ OFF
- 9 Press **▼**, and press the **ENTER** key.
• “TAKE-UP TENSION BAR” will be selected.
- 10 Press **▲▼** to select a set value, and press the **ENTER** key.
• Set Value : ON/ OFF
- 11 Press **▼**, and press the **ENTER** key.
• “Feeding/ Take-up SW” will be selected.
- 12 Press **▲▼** to select a set value, and press the **ENTER** key.
• Set Value : Continuance/ Temporary
Continuance :
Switching ON / OFF the winding operation when pressing the switch each time. (Take-up unit in operation does not stop until press again ON / OFF switch.)
Temporary :
Do the winding operation only while holding down the switch. (When release the switch, winding operation is stopped.)

Important!

- If you are using the direct-connection unit, the winding operation will be carried out with the “TEMPORARY” setting even if you select “CONTINUANCE”.

- 13 Press the **END/POWER** key several times to end the setting.

Important!

- Set feeding/take-up tension bar in “FEEDING/ TAKE-UP” before setting media. Even if you try after detecting the media width (P.2-26), you cannot set feeding/take-up tension bar.
- You can change the ON/OFF settings of Feeding/ Take-up unit after detecting the media width.
When turning OFF from ON
Feeding/take-up unit does not operate.
When turning ON from OFF
If torque limiter is attached, only take-up operation without using tension bar is performed.
If direct-connection unit is attached, take-up operation is not performed.
- If you want to change the feeding/ take-up method while setting media, remove the set media and carry out the operations from step 1 again.

Setting Top Blower

Set the operation of the top blower in print.
Turn the top blower setting “ON”, and you can set the strength for the blower.

- 1 Press **FUNC1 (MENU)** → **▼** (twice) → **ENTER** in LOCAL.
• MACHINE SETUP MENU will be displayed.
- 2 Press **▲▼** to select “Top blower”, and press the **ENTER** key.
- 3 Press **▲▼** to select “ON”, and press the **ENTER** key.
ON : You can choose the air volume of the blower.
OFF : The top blower does not work while printing process. Proceed to step 6.
- 4 Press **▲▼** to select “STRENGTH”, and press the **ENTER** key.
- 5 Press **▲▼** to select a set value (AUTO/ STRONG/ WEAK), and press the **ENTER** key.
• Set value : ON/ OFF
- 6 Press the **END/POWER** key several times to end the setting.

Setting the Display of Media Residual

Whether the screen displays the remaining amount of a media is set.

When the media remaining amount display is turned to "ON"	the remaining amount of a media is displayed in Remote. (However, when a leaf media is used, the length of the media to be printed is displayed.)
When the media remaining amount display is turned to "OFF"	the remaining amount of a media is not displayed in the Remote.



- The amount of a media that has been fed by the printing and jog keys is reflected in the remaining amount of a media.
- The length of a media (initial value of the remaining amount) is entered when a roll media is detected. (P.2-27)
- The setting configured here does not become effective unless media detection is performed after the setting has been complete.

1 Press **FUNC1 (MENU)** → **▼** (twice) → **ENTER** in LOCAL.

- MACHINE SETUP MENU will be displayed.

2 Press **▲▼** to select "MEDIA REMAIN", and press the **ENTER** key.

3 Press **▲▼** to select ON/OFF.

4 Press the **ENTER** key.

5 Press the **END/POWER** key several times to end the setting.



- When set "ON" the media remaining display, you can print the list of current media remaining amount and the date. (P.2-27)

Setting the PG Drop Adjust

Adjust the outward and return ink drop positions during bidirectional printing.

PG Drop Adjust adjusts the ink drop positions at two points where the head height is not the same, so that high quality printing can be realized by automatically adjusting the ink drop positions even if the head height changes.

1 Press **FUNC1 (MENU)** → **▼** (twice) → **ENTER** in LOCAL.

- MACHINE SETUP MENU will be displayed.

2 Press **FUNC3 (>>)**.

3 Press **▲▼** to select "PG DROP ADJUST", and press the **ENTER** key.

4 Loosen the carriage height adjustment screw and press the **ENTER** key.

- Loosen the screen by referring to P.2-8 "Adjusting the Head Height" .

5 With the head height set as 3 mm, tighten the height adjustment screw.

6 Press the **ENTER** key twice.

- Ink drop position adjustment patterns 1 to 5 will be printed.

7 Correct the dot positions in patterns 1 to 5 by referring to P.3-6 "If the Positions of Dots Shift...".

8 By referring to steps 4 to 7, change the head height to 4 mm and then correct the dot positions in patterns 1 to 5.

9 Press the **END/POWER** key several times to end the setting.

Setting the Media Detection

Set the following two items in media detection settings.

Setting of Media Detection	When setting the media, set whether to detect the media width automatically (AUTO) or decide the print range manually (MANUAL).
Setting of Media Thickness	Set whether to enter the thickness of the media during media detection.
Winding diameter detection	Select auto detection (AUTO) or manual setting (MANUAL) for the media outer diameter of both take-up unit and feeding unit.



- To perform over printing, turn the media detection settings to "MANUAL".

1 Press **FUNC1 (MENU)** → **▼** (twice) → **ENTER** in LOCAL.

- MACHINE SETUP MENU will be displayed.

- 2 Press **FUNC3** (>>).
- 3 Press **▲▼** to select "MEDIA DETECT", and press the **ENTER** key.
- 4 Press the **ENTER** key.
 - "DETECTION TYPE" will be selected.
- 5 Press **▲▼** to select "AUTO/MANUAL", and press the **ENTER** key.
- 6 Press **▲▼** to select "INPUT THICKNESS", and press **ENTER**.
- 7 Press **▲▼** to select ON/OFF, and press the **ENTER** key.
- 8 Press **▲▼** to select "DIA.DETECT" and press the **ENTER** key
- 9 Press **▲▼** to select AUTO / MANUAL and press the **ENTER** key
- 10 Press the **END/POWER** key several times to end the setting.

Important! • To improve image quality for printing, we recommend selecting "ON" in step 7.

Setting the Drying Feed

After printing, set the media feed length for drying uniformly to the end of the media.



• According to the position of your external heater, please configure that the rear end of printing can pass through the heater.

- 1 Press **FUNC1** (MENU) → **▼** (twice) → **ENTER** in LOCAL.
 - MACHINE SETUP MENU will be displayed.
- 2 Press **FUNC3** (>>).
- 3 Press **▲▼** to select "DRYING FEED", and press the **ENTER** key.
- 4 Press the **ENTER** key.
 - "DRYING FEED" will be selected.
- 5 Press **▲▼** to input the feed length of media, and press the **ENTER** key.
- 6 Press the **END/POWER** key several times to end the setting.

Setting a LANGUAGE

You can change the displayed language.

- 1 Press **FUNC1** (MENU) → **▼** (twice) → **ENTER** in LOCAL.
 - MACHINE SETUP MENU will be displayed.
- 2 Press **FUNC3** (>>).
- 3 Press **▲▼** to select "LANGUAGE", and press the **ENTER** key .
- 4 Press **▲▼** to select language, and press the **ENTER** key .
- 5 Press the **END/POWER** key several times to end the setting.

Setting Time

You can set time of your country (time difference).

- 1 Press **FUNC1** (MENU) → **▼** (twice) → **ENTER** in LOCAL.
 - MACHINE SETUP MENU will be displayed.
- 2 Press **FUNC3** (>>).
- 3 Press **▲▼** to select "TIME", and press the **ENTER** key.
- 4 Press **▲▼◀▶** to enter time, and press the **ENTER** key.
 - Year/Month/Day/Time selecting: by the [**◀**][**▶**]
 - Year/Month/Day/Time inputting: by the [**▲**][**▼**]
- 5 Press the **END/POWER** key several times to end the setting.



• -20 hours to +4 hours can be set.

Setting Unit (Temperature/ Length)

Units used by this machine are set.

- 1 Press **FUNC1** (MENU) → **▼** (twice) → **ENTER** in LOCAL.
• MACHINE SETUP MENU will be displayed.
- 2 Press **FUNC3** (>>) twice.
- 3 Press **▲▼** to select “UNIT/TEMP.” or “UNIT/LENGTH”, and press the **ENTER** key.
- 4 Press **▲▼** to select a set value, and press the **ENTER** key.
• Set value of temperature: °C / °F
• Set value of length : mm / inch
- 5 Press the **END/POWER** key several times to end the setting.

Setting a KEY BUZZER

You can turn off the buzzer sound when pressing the key.

- 1 Press **FUNC1** (MENU) → **▼** (twice) → **ENTER** in LOCAL.
• MACHINE SETUP MENU will be displayed.
- 2 Press **FUNC3** (>>) twice.
- 3 Press **▲▼** to select “KEY BUZZER”, and press the **ENTER** key.
- 4 Press **▲▼** to select a set value, and press the **ENTER** key.
• Set value : ON/ OFF
- 5 Press the **END/POWER** key several times to end the setting.



- When the key buzzer is set to "OFF", the buzzer sound for errors, warnings, operation completion, etc. cannot be shut off.

Setting the VIEW FEED

Set whether media feeding is performed for checking the result of the test printing etc. or not.

- 1 Press **FUNC1** (MENU) → **▼** (twice) → **ENTER** in LOCAL.
• MACHINE SETUP MENU will be displayed.
- 2 Press **FUNC3** (>>) twice.
- 3 Press **▲▼** to select “VIEW FEED”, and press the **ENTER** key .
- 4 Press **▲▼** to select a set value, and press the **ENTER** key .
• Set value : ON/ OFF
- 5 Press the **END/POWER** key several times to end the setting.

Setting the amount of blank space between printed lines

Sets the amount of blank space between printed lines.

- 1 Press **FUNC1** (MENU) in Local.
- 2 Press **▲▼** to select “Machine Setup”, and press the **ENTER** key .
- 3 Press **FUNC1** (>>) twice.
- 4 Press **▲▼** to select “Space Btwn PP.”, and press the **ENTER** key .
- 5 Press **▲▼** to set the amount of blank space, and press the **ENTER** key .
• Set value : None / 10 to 500 mm
- 6 Press the **END/POWER** key several times to end the setting.



- If the printed data already has a blank space, using this function will result in “Blank space of the data + Amount of blank space set by using this function” being output as a blank space.

Setting the SPACE FEED MODE

Change the feed mode of the margin included in the image data (the space of no data to be printed). If print data with much margin, set to "continuous", then the print time can be shorten.

- 1 Press the **FUNC1** (MENU) \rightarrow **▼** (twice) \rightarrow **ENTER** key in LOCAL.
 - MACHINE SETUP MENU will be displayed.
- 2 Press **FUNC3** (>>) twice.
- 3 Press **▲** **▼** to select "SPACE FEED MODE", and press the **ENTER** key.
- 4 Press **▲** **▼** to select a set value, and press the **ENTER** key.
 - INTERMITTENT : Perform intermittent feed operation of the path division unit
 - CONTINUOUS : Feed the no data part at a time
- 5 Press the **END/POWER** key several times to end the setting.

Set the network

You can also perform network setting with "Network Configurator", the tool to perform network setting of Mimaki's product. To download the Network Configurator, check "Driver / Utility" on the download page at Mimaki Engineering (<https://mimaki.com/download/>).

- 1 Press **FUNC1** (MENU) \rightarrow **▼** (twice) \rightarrow **ENTER** in LOCAL.
 - MACHINE SETUP MENU will be displayed.
 - 2 Press **FUNC3** (>>) twice.
 - 3 Press **▲** **▼** to select "NETWORK", and press the **ENTER** key.
 - 4 Press the **ENTER** key.
 - "CHECK IP ADDRESS" will be selected.
 - The IP address currently used by this machine is displayed.
 - When you have finished the check, press the [ENTER] key.
-  • After connecting with the network, it takes time until the IP address is determined. If the IP address has not been determined, "0.0.0.0" is displayed.
- 5 Press **▼**, and press the **ENTER** key.
 - "CHECK MAC ADDRESS" will be selected.
 - The MAC address currently used by this machine is displayed.
 - When you have finished the check, press the [ENTER] key.
 - 6 Press **▼**, and press the **ENTER** key.
 - "DHCP" will be selected.

- 7 Press **▲** **▼** to select a set value, and press the **ENTER** key.
 - Set value : ON/ OFF
 - When it is ON, the IP address given by the DHCP server is used.
- 8 Press **▼**, and press the **ENTER** key.
 - "AutoIP" will be selected.
- 9 Press **▲** **▼** to select a set value, and press the **ENTER** key.
 - Set value : ON/ OFF
 - When it is ON, the IP address is determined by the AutoIP protocol. However, DHCP is ON, DHCP has priority.
- 10 Press **▼**, and press **ENTER** .
 - "IP ADDRESS" will be selected.
- 11 Press **▲** **▼** to select a set value, and press the **ENTER** key.
 - Set value : ON/ OFF
 - Both of DHCP and AutoIP is OFF, you can set IP Address. For other than above, proceed to the Step 14.
- 12 Press **FUNC3** .
 - The setting items DEFAULT GATEWAY, DNS ADDRESS and SUBNET MASK will be displayed.
 - Both of DHCP and AutoIP is OFF, you can set DEFAULT GATEWAY/ DNS ADDRESS/ SUBNET MASK. For other than above, proceed to the Step 14.
- 13 Press **▼** several times to select setting item, and press the **ENTER** key.
- 14 Press **▲** **▼** to select a set value, and press the **ENTER** key.
- 15 Press the **END/POWER** key several times to end the setting.



- To reflect network setting, once turn off the power supply and turn it on again.

Setting event mail function

Set the function to send e-mails to the set e-mail address when events such as cutting start/ end and stop due to an error.

You can also perform network setting with "Network Configurator", the tool to perform network setting of Mimaki's product. To download the Network Configurator, check "Driver / Utility" on the download page at Mimaki Engineering (<https://mimaki.com/download/>).

- Disclaimer
- The customer is responsible for the communication fee for Internet communication such as e-mail notification.
- The notification by the event mail function may not be delivered due to Internet environment, failure of the device/ the power supply, etc. Mimaki has absolutely no responsibility for any damages or loss resulting from non-delivery or delays.

Important!

- You can use event mail function by connecting LAN to this machine. Please prepare for LAN cable connection beforehand.
- Not compatible with SSL communication.

Enable the event mail function

- 1 Press **FUNC1** (MENU) → **▼** (twice) → **ENTER** in LOCAL.
• MACHINE SETUP MENU will be displayed.
- 2 Press **FUNC1** (<<).
- 3 Press **▲▼** to select "EVENT MAIL", and press the **ENTER** key.
- 4 Press the **ENTER** key.
• "MAIL DELIVERY" will be selected.
- 5 Press **▲▼** to select "ON", and press the **ENTER** key.
- 6 Press the **END/POWER** key several times to end the setting.

Set the event to send an event mail

- 1 Press **FUNC1** (MENU) → **▼** (twice) → **ENTER** in LOCAL.
• MACHINE SETUP MENU will be displayed.
- 2 Press **FUNC1** (<<).
- 3 Press **▲▼** to select "EVENT MAIL", and press the **ENTER** key.
- 4 Press **▼**, and press the **ENTER** key.
• "SELECT EVENT" will be selected.
- 5 Press **▲▼** to select the "ON" or "OFF" of the event, then press the **ENTER** key.

- Select the ON / OFF of the event in the order shown in the table below. After the ON / OFF setting, please proceed to the next event settings by pressing the [ENTER] key.
- Press the [END / POWER] key when you return to the previous setting.

Event name	Outline
PRINT START	Sets sending/not sending of an email when printing starts.
PRINT END	Sets sending/not sending of an email when printing ends.
ERROR	Sets sending/not sending of an email when printing is stopped due to occurrence of an error.
WARNING	Sets sending/not sending of an email when a warning occurs during printing.
etc.	Sets sending/not sending of an email when an event other than the above occurs.

- 6 Press the **END/POWER** key several times to end the setting.

Set the e-mail address

- 1 Press **FUNC1** (MENU) → **▼** (twice) → **ENTER** in LOCAL.
• MACHINE SETUP MENU will be displayed.
- 2 Press **FUNC1** (<<).
- 3 Press **▲▼** to select "EVENT MAIL", and press the **ENTER** key.
- 4 Press **▼** twice, and press the **ENTER** key.
• "MAIL ADDRESS" will be selected.
- 5 Press **▲▼◀▶** to set mail address, and press the **ENTER** key.
• Set the e-mail address to which you send the event mail.
• Set it with alphanumeric characters and symbols within 96 characters.
- 6 Press the **END/POWER** key several times to end the setting.

Set the subject

- 1** Press **FUNC1** (MENU) \rightarrow **▼** (twice) \rightarrow **ENTER** in LOCAL.
 - MACHINE SETUP MENU will be displayed.
- 2** Press **FUNC1** (<<).
- 3** Press **▲▼** to select "EVENT MAIL", and press the **ENTER** key.
- 4** Press **▼** 3 times, and press the **ENTER** key.
 - "MESSAGE SUBJECT" will be selected.
- 5** Press **▲▼◀▶** to set subject, and press the **ENTER** key.
 - Set the characters to write in the subject of the event mail.
 - Set it with alphanumeric characters and symbols within 8 characters.
- 6** Press the **END/POWER** key several times to end the setting.

Set the server

- 1** Press **FUNC1** (MENU) \rightarrow **▼** (twice) \rightarrow **ENTER** in LOCAL.
 - MACHINE SETUP MENU will be displayed.
- 2** Press **FUNC1** (<<).
- 3** Press **▲▼** to select "EVENT MAIL", and press the **ENTER** key.
- 4** Press **▼** 4 times, and press the **ENTER** key.
 - "SERVER SETUP" will be selected.
- 5** Press the **ENTER** key.
 - "SMTP ADDRESS" will be selected.
- 6** Press **▲▼◀▶** to set SMTP Address, and press the **ENTER** key.
 - Press jog key **▲▼◀▶** to set SMTP address.
 - Input the SMTP address name.
- 7** Press **▼**, and press the **ENTER** key.
 - "SMTP PORT No." will be selected.
- 8** Press **▲▼** to set SMTP Port No., and press the **ENTER** key.
 - Set the SMTP port number.
- 9** Press **▼**, and press the **ENTER** key.
 - "SENDER ADDRESS" will be selected.
- 10** Press **▲▼◀▶** to set SENDER ADDRESS, and press the **ENTER** key.

- Press **▲▼◀▶** and set the e-mail address to be used as the sender mail address.
- Set it with alphanumeric characters and symbols within 64 characters.



- Depending on your server, if you do not set the e-mail address not supporting the account, sending/ receiving e-mails may be unavailable.

- 11** Press **▼**, and press the **ENTER** key.
 - "AUTHENTICATION" will be selected.
 - 12** Press **▲▼** to set authentication method, and press the **ENTER** key.
 - Set the authentication method of the SMTP server.
 - When you select [OFF], proceed to the Step 20.
 - 13** Press **▼**, and press the **ENTER** key.
 - "USER NAME" will be selected.
 - 14** Press **▲▼◀▶** to set User Name, and press the **ENTER** key.
 - Press **▲▼◀▶** to set the user name to use for the authentication.
 - Set it with alphanumeric characters and symbols within 30 characters.
 - 15** Press **▼**, and press the **ENTER** key.
 - "PASSWORD" will be selected.
 - 16** Press **▲▼◀▶** to set Password, and press the **ENTER** key.
 - Press **▲▼◀▶** to set the password to use for the authentication.
 - Set it with alphanumeric characters and symbols within 15 characters.
- On the password setting screen, you can only check the value that you are currently inputting.
- 17** Press **▼**, and press the **ENTER** key.
 - "POP3 ADDRESS" will be selected.
 - 18** Press **▲▼◀▶** to set POP3 Address, and press the **ENTER** key.
 - Press **▲▼◀▶** to set POP server.
 - Input the POP server name.
 - 19** Press **▼**, and press the **ENTER** key.
 - "APOP" will be selected.
 - 20** Press **▲▼** to set ON/ OFF, and press the **ENTER** key.
 - 21** Press the **END/POWER** key several times to end the setting.

Send a test e-mail

- 1** Press **FUNC1** (MENU) \rightarrow **ENTER** (twice) \rightarrow **ENTER** in LOCAL.
 - MACHINE SETUP MENU will be displayed.
- 2** Press **FUNC1** (<<).
- 3** Press **UP** **DOWN** to select "EVENT MAIL", and press the **ENTER** key.
- 4** Press **FUNC3** (>>) \rightarrow **ENTER** .
 - "TRANSMIT TEST" will be selected.

- 5** Press the **ENTER** key.
 - The sent result is displayed.
 - If sending test e-mail has failed, an error code is displayed.
Refer to the next page to solve the problem.

```

Transmit Test
Failed: 12345      :ent
    
```

Error code

- 6** Press the **END/POWER** key several times to end the setting.

Important!

- The sent result of the test e-mail is the result of e-mail sending process performed by this machine to the e-mail server. It does not indicate that the e-mail was received at the address.
- If the spam e-mail filter etc. has been set in the terminal in which e-mails are received, even if "Sending has been completed" is displayed, the e-mail cannot be received in some cases.
- If sending test e-mail has failed, the error code below is displayed.
- If the error cannot be solved, try again after a while.
- For the server setting etc., contact with the network administrator or the provider.

Error Code	The expected causes	Remedy
10	Network connection error	<ul style="list-style-type: none"> • Check that the machine is connected with the network. • Check that the machine IP address is correct. • Check that the machine is in the environment where DNS is available.
20	No valid e-mail address.	<ul style="list-style-type: none"> • Enter the correct e-mail address.
11003 11004	The POP server cannot be found. Or cannot access DNS server.	<ul style="list-style-type: none"> • Check the POP server address. • Check that the machine is in the environment where DNS is available.
11021	Cannot connect with the POP server.	<ul style="list-style-type: none"> • Check the POP server setting. • Check the firewall setting.
12010	An error returns from the POP server.	<ul style="list-style-type: none"> • Check the POP server setting.
13000	The POP authentication has failed.	<ul style="list-style-type: none"> • Check the user name and the password. • Check the APOP setting. • Confirm the authentication method.
10013 10014	The SMTP server cannot be found. Or cannot access DNS server.	<ul style="list-style-type: none"> • Check the SMTP server address. • Check that the machine is in the environment where DNS is available.
10021	Cannot connect with the SMTP server.	<ul style="list-style-type: none"> • Check the SMTP server setting. • Check the SMTP port number. • Check the firewall setting.
10*** 11*** 20*** 21***	An error returns from the SMTP server. Or, there was no response.	<ul style="list-style-type: none"> • Check the SMTP server setting. • Cannot communicate with a server that requires mandatory SSL communication. • Check protocol filter settings.
12***	It is invalid sender address.	<ul style="list-style-type: none"> • Check that the e-mail address supporting the account entered in the user name/ the password is set in SENDER ADDRESS.
13***	The e-mail address cannot be found. Or, it is invalid sender address.	<ul style="list-style-type: none"> • Check the e-mail address. • Even if there is a mistake in the e-mail address, this error cannot be detected in some cases. • Check that the e-mail address supporting the account entered in the user name/ the password is set in SENDER ADDRESS.
22000 22008	SMTP authentication error	<ul style="list-style-type: none"> • Confirm the authentication method.
23*** 24*** 25***	The SMTP authentication has failed.	<ul style="list-style-type: none"> • Check the user name and the password.

“***” is the error code returned from the e-mail server.

Initializing the Settings

You can return the setting of “SETUP”, “MAINTENANCE” and “MACHINE SETUP” to the status before shipment.

- 1** Press **FUNC1** (MENU) → **▼** (twice) → **ENTER** in LOCAL.
 - MACHINE SETUP MENU will be displayed.
- 2** Press **FUNC1** (<<).
- 3** Press **▲** **▼** to select “RESET”, and press the **ENTER** key.
- 4** Press the **ENTER** key.
 - The already configured settings are initialized.
- 5** Press the **END/POWER** key several times to end the setting.

About NOZZLE CHECK MENU

Set operations concerning the nozzle missing detection function.

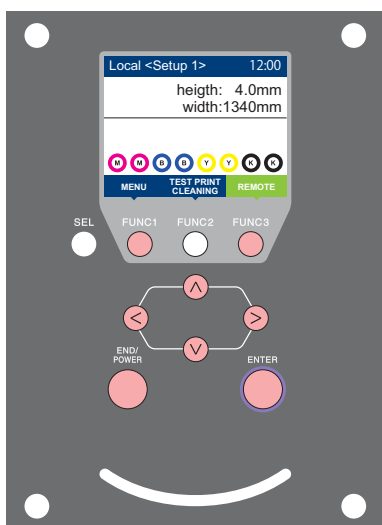

- FUNC1** : Press this to select INFORMATION MENU, or to switch to the previous screen.
- FUNC3** : Press this to switch to the next screen.
- ▲ ▼** : Use these to select a setting item.
- ENTER** : Press this to confirm a setting, etc..

◆ NOZZLE CHECK MENU at-a-glance

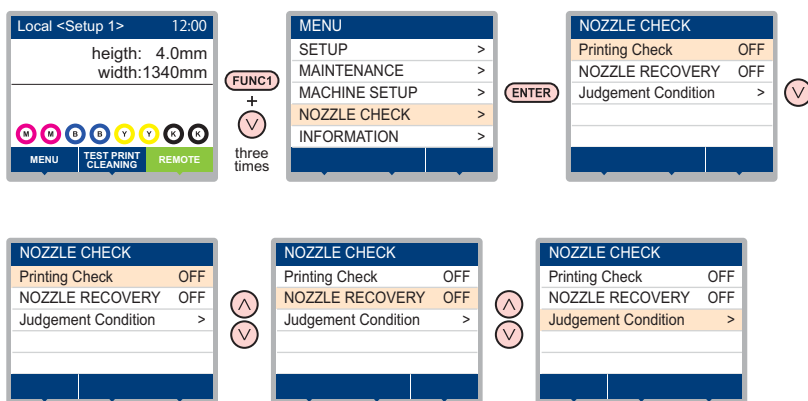

INFORMATION MENU table

Function name		Set value	Default	Meaning	
(ON)	Printing Check (P.3-25)	ON/OFF	OFF	Set this when you want to conduct nozzle check at the beginning of online printing.	
		Check Interval	LENGTH	0.1 to 50.0 m	30.0 m
	FILE		1 to 100	30 file	Conducts nozzle check at each set number of files. *1
	Action	CLEANING	OFF/ SOFT/ NORMAL/ HARD	SOFT	Sets the type of cleaning performed during recovery work.
RETRY COUNT		0 to 3	0	Repeats the retry operation for the set number of times.	
NOZZLE RECOVERY (P.3-26)		ON/OFF	OFF	Set this when you want to conduct automatic nozzle recovery.	
Judgement Condition (P.3-26)		1 to 200	1	Sets how many missing nozzles are detected for "Nozzle Missing" judgment to be made according to each color. (Maximum 16 per 1 nozzle line)*2	

*1. When the set length is reached during printing, nozzle check is conducted at the start of the next printing.

*2. Depending on the print conditions, nozzle recovery is not applied in some cases.

Printing Check Flow

Nozzle check is conducted according to the following flow at the start of printing.



- Turn the “Printing Check” setting ON to be enabled.
- Only perform RETRY COUNT and Printing Check settings when the settings are enabled.

1 nozzle check → Judgment

Detects missing nozzles.

2 Recovery operation → nozzle check → Judgment

If more missing nozzles than “Judgement Condition ” are detected after the nozzle check, cleaning is performed and nozzle check is conducted again.

3 Retry → Judgment

If more missing nozzles than “Judgement Condition ” are detected after the recovery operation, the recovery operation is conducted again.

4 Printing Check → Judgment

Nozzle recovery is automatically conducted following nozzle check and recovery operation.

- Turn the “Printing Check” setting ON to be enabled.

5 Nozzle Missing judgment

If more missing nozzles than A are eventually detected, continued printing will be deemed impossible and printing will stop.

3

Printing Operations at “Nozzle Missing” Judgment and Error Occurrence

- When judged to be “Nozzle Missing” → Printing is stopped.
- When error occurs during nozzle check → Printing is stopped and “Printing Check” is automatically turned OFF. After recovering from the error, set “Printing Check” once again.

Setting the Printing Check

Select ON when you want to conduct nozzle check at the start of online printing.

- 1 Press **FUNC1** (MENU) → **▼** (3 times) → **ENTER** in LOCAL.
 - NOZZLE CHECK MENU will be displayed.
- 2 Press the **ENTER** key.
 - “Printing Check” will be selected.
- 3 Press **▲▼** to select ON, and press the **ENTER** key.
 - The “Check Interval” setting screen will be displayed.
 - “Select OFF to not set nozzle check. Proceed to Step 11.
- 4 Press the **ENTER** key.
- 5 Press **▲▼** to select setting item, and press the **ENTER** key.
 - select the nozzle check interval from “LENGTH” or “FILE”.
 - LENGTH** : nozzle check is conducted when the printed length reaches the set length.
 - FILE** : nozzle check is conducted when the number of printed files reaches the set number.
- 6 Press **▲▼** to select setting value, and press the **ENTER** key.
 - The set value will differ according to the setting selected in Step 5.
 - LENGTH** : 0.1 to 50.0 m
 - FILE** : 1 to 100 files
- 7 Press the **ENTER** key twice.
 - The “Action” setting screen will be displayed.
- 8 Press the **ENTER** key.
 - “CLEANING TYPE” will be selected.
- 9 Press **▲▼** to select cleaning type, and press the **ENTER** key.
 - Setting value : OFF/SOFT/ NORMAL/ HARD
- 10 Press **▲▼** to select retry count, and press **ENTER** .
 - Setting value : 0 to 3
- 11 Press the **END/POWER** key several times to end the setting.

Setting the NOZZLE RECOVERY

set this if you want to conduct automatic nozzle recovery when nozzle missing is detected.

- 1 Press **FUNC1** (MENU) → **▼** (3 times) → **ENTER** in LOCAL.
 - NOZZLE CHECK MENU will be displayed.
- 2 Press **▼**, and press the **ENTER** key.
 - “NOZZLE RECOVERY” will be selected.
- 3 Press **▲▼** to select ON/OFF, and press **ENTER** .
- 4 Press the **END/POWER** key several times to end the setting.

Setting the Judgement Condition

Set the conditions for judging nozzle missing.

- 1 Press **FUNC1** (MENU) → **▼** (3 times) → **ENTER** in LOCAL.
 - NOZZLE CHECK MENU will be displayed.
- 2 Press **▼** twice, and press the **ENTER** key.
 - “Judgement Condition” will be selected.
- 3 Press **▲▼** to select color, and press the **ENTER** key.
 - 
 - The type of color changes depending on the ink set.
- 4 Press **▲▼** to set the number of nozzles for judgment, and press the **ENTER** key.
- 5 Press the **END/POWER** key several times to end the setting.

About INFORMATION MENU

The information of this machine can be confirmed.
The following items can be confirmed as machine information.

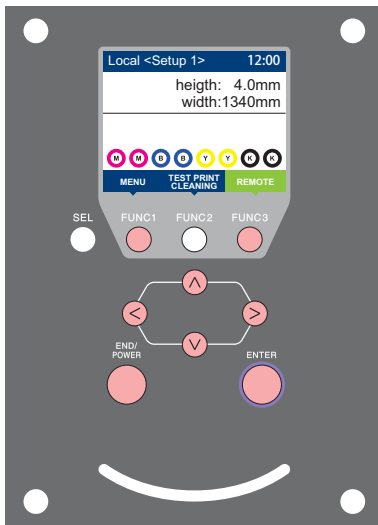

FUNC1 : Press this to select INFORMATION MENU, or to switch to the previous screen.

FUNC3 : Press this to switch to the next screen.

▲ ▼ : Use these to select a setting item.

ENTER : Press this to confirm a setting, etc..

◆ INFORMATION MENUs at-a-glance

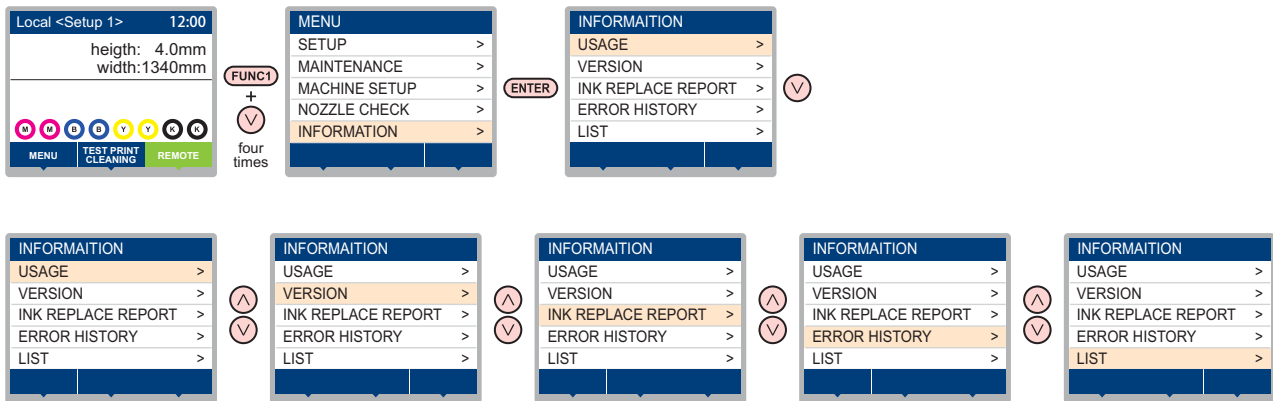

INFORMATION MENU table

Item	Description	
USAGE	WIPING	This displays how many wiping have been done.
	WASTE TANK	This displays how much waste ink has built up in the waste ink tank, as a rough percentage of the tank capacity.
	PRINT LENGTH	This displays the total length of the printing done to date.
	PRINT AREA	This displays the total area of the printing done to date.
	USE TIME	This displays the total time for which the printer has been used to date.
	Spout Rubber	This displays the total time for which Spout Rubber has been used.
VERSION	This displays the version information of this machine.	
Ink REPL. Report	This prints ink history of this machine.	
ERROR HISTORY	This displays the history of errors and warnings to date. When you press [▲][▼], the date of occurrence (year/month/day/hour/minute) and the error/warning information are displayed alternately in the order of occurrence.	
LIST	This allows you to print the settings of this machine.	

Displaying the Information

- 1 Press **FUNC1** (MENU) → **▼** (4 times) → **ENTER** in LOCAL.
 - INFORMATION MENU will be displayed.
- 2 Press **▲** **▼** to select a information.
 - Refer to the “INFORMATION MENU”, and select the information to be displayed.
- 3 Press the **ENTER** key.
 - If you selected [LIST] in step 2, the machine’s settings will be printed.
- 4 Press the **END/POWER** key several times to end the setting.



- When you reset the used count of the wiper, press [FUNC2] key while [RESET?] is displayed. When you press the [ENTER] key, the number of wiping is reset.
- By pressing the function key during display of “WIPING information,” “WASTE TANK information” and “Spout Rubber” in USAGE, the used counts can be reset.

When resetting WIPING information	: Press [FUNC2]
When resetting WASTE TANK information	: Press [FUNC1]
When resetting Spout Rubber	: Press [FUNC3]

Chapter 4

Maintenance



This chapter

describes the items required to use this machine more comfortably, which are the methods for the daily care, the maintenance of the ink cartridges etc.

Maintenance	4-2	Nozzle Recovery Function	4-18
When to care	4-2	Reset the set value	4-19
Precautions for Maintenance	4-3	Check the condition for which nozzle recovery cannot be performed	4-19
About Cleaning Solution	4-3	Enabling or disabling nozzle recovery during a test print	4-20
Cleaning the Exterior Surfaces	4-3	Automatic Maintenance Function	4-21
Cleaning the Media Sensor	4-3	Setting the Refreshing Intervals	4-21
Cleaning folding bar (take-up side)	4-4	Setting the Tube Wash Intervals	4-21
Cleaning the tension roller	4-4	Setting the Cleaning Intervals and Type	4-22
Cleaning the Ink receiving spacer	4-4	Suspend the nozzle cleaning	4-22
Cleaning the Platen	4-4	Fill up Ink	4-22
Cleaning the Fabric Retainer / Media press	4-6	Replacing consumables	4-23
Cleaning of grit roller	4-6	Replacing the wiper	4-23
About MAINTENANCE MENU	4-8	If a Waste Ink Tank Confirmation Message Appears	4-24
MAINTENANCE MENU at-a-glance	4-9	Replace the waste ink tank with another ...	4-24
Maintaining the Capping Station	4-10	Replacing the Cap Absorber	4-25
Cleaning the Wiper and Cap	4-10	Replacing the Blow down fan filter	4-26
Cleaning the Cap Absorber	4-12	Replacing the Pinch roller	4-27
Washing the Head Nozzle	4-12	Replacing the Spout Rubber	4-28
Washing the Ink Discharge Passage	4-13	Male Connector Absorbent for MBIS	4-29
When the Machine Is Not Used for a Long Time	4-14		
Cleaning the Ink Head and the Area around It	4-16		
Cleaning around the Ink Head	4-16		
Clean the edge of the head nozzle surface	4-17		

Maintenance

Maintain the machine regularly or as necessary so that its accuracy will be maintained and it can continue to be used for a long time.

When to care

This machine is a precision machine equipped with extremely fine mechanisms. Especially, the nozzle surface of the heads from which the ink is discharged is affected even by a slightest attachment of dust or paper powder and the proper printing results could not be obtained. With a view to using this machine in a better condition, we would like to recommend performing the following care and maintenance on daily basis.

When to care	What to care	Reference Page
When replace the media	Cleaning the Ink receiving spacer	P.4-4 "Cleaning the Ink receiving spacer"
Once a day (at the end of the daily work)	Surroundings of the heads	P.4-16 "Cleaning the Ink Head and the Area around It"
	Capping station	P.4-10 "Cleaning the Wiper and Cap"
	Wiper	P.4-10 "Cleaning the Wiper and Cap"
	Media press	P.4-6 "Cleaning the Fabric Retainer / Media press"
	Media sensor	P.4-3 "Cleaning the Media Sensor"
Once a week (at the end of the work on weekend)	Platen	P.4-4 "Cleaning the Platen"
	Cleaning lupal bar (take-up side)	P.4-4 "Cleaning folding bar (take-up side)"
	Cleaning the tension roller	P.4-4 "Cleaning the tension roller"
	Exterior	P.4-3 "Cleaning the Exterior Surfaces"
	Waste ink tank	P.4-24 "If a Waste Ink Tank Confirmation Message Appears"
	Ink Discharge Passage	P.4-13 "Washing the Ink Discharge Passage"
	Clean the edge of the head nozzle surface	P.4-17 「Clean the edge of the head nozzle surface」
Once a month	Fill up Ink (Only for Sb411+TP400 ink set)	P.4-22 "Fill up Ink"
When the platen is replaced (Tx300P-1800 MkII only)	Cleaning the Platen	P.4-4 "Cleaning the Platen"
	Cleaning the Ink receiving spacer	P.4-4 "Cleaning the Ink receiving spacer"
	Media press	P.4-6 "Cleaning the Fabric Retainer / Media press"
In the event of damage, deformation, excessive dirt, or when periodic replacement is required	Replacement of supply parts	P.4-23 "Replacing consumables"
Once a year When the Machine Is Not Used for a Long Time	Perform "CUSTODY WASH".	P.4-14 "When the Machine Is Not Used for a Long Time"



• Tools required for maintenance





- Cleaning stick (SPC-0527)
- Cleaning Liquid
- Cotton swab
- Safety glasses
- Gloves
- Soft fabric



- The maintenance cleaning liquid is different by use ink type. Use the cleaning liquid dedicated for the ink being used. (☞ P.4-3)

Precautions for Maintenance

Pay attention to the following items when maintaining this machine.

	<ul style="list-style-type: none"> When using cleaning solution for maintenance, be sure to wear the supplied protective glasses. When cleaning the ink-station or the heads, be sure to wear the included safety glasses and gloves.
	<ul style="list-style-type: none"> Never disassemble the machine. Disassembling it can result in electric shock hazards or damage to the machine. Before maintenance, be sure to turn off the power switch and unplug the power cable; otherwise, an unexpected accident may occur.
	<ul style="list-style-type: none"> Prevent moisture from entering the machine. Moisture inside the machine can cause electric shock hazards or damage to the machine.
	<ul style="list-style-type: none"> To ensure stable ink jetting, it is necessary for the machine to eject a small amount of ink (flushing) regularly when a printing (outputting) operation has not been performed for a long time. When the machine is not to be used for a long time, turn off only the power switch on the front side, leave the main power switch at the right side turned ON (in the position of), and leave the power cable connected.
	<ul style="list-style-type: none"> Do not wipe the nozzle face of the heads, wiper, caps, etc. with water or alcohol. Doing so can cause nozzle clogging or machine failure. Do not use benzene, thinner, or any chemical agent containing an abrasive. Such materials can deteriorate or deform the surface of the cover. Do not apply a lubricant, etc. to any parts inside the machine. Doing so can cause printing failure. Be careful that the cleaning solution, ink, etc. not to stick to the cover because this may cause the surface of the cover to deteriorate or deform.

About Cleaning Solution

Use the cleaning liquid dedicated for the ink being used.

Type of Ink	Applicable maintenance washings
Dye Sublimation ink:Sb420 Dye Sublimation ink:Sb421 Disperse dye ink :Dd400 Acid-dye ink :Ac400 Reactive-dye ink :Rc400 Reactive-dye ink :Rc500	Cleaning Liquid 03 MAINTENANCE KIT (ML003-2-K1) [Sold separately]
Hybrid ink : Sb411+Sb420	
Textile pigment ink :TP400	Cleaning Liquid 12 MAINTENANCE KIT (C-ML012-Z-K1-1-KW) [Sold separately]
Hybrid ink : Sb420+TP400	
Hybrid ink : Sb421+TP400	
Hybrid ink : Sb411+TP400	

Cleaning the Exterior Surfaces

When the exterior surfaces of the machine are stained, dampen a soft cloth with water or a neutral detergent diluted with water, squeeze it, and wipe the surfaces with the cloth.

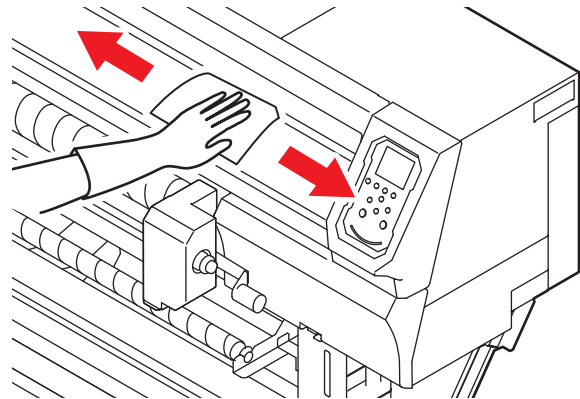

Cleaning the Media Sensor

The media sensors are located on the platen in the backside and the bottom surface of the head. When the sensor is covered with dust, etc., it may cause false detection of media.

Using a cotton swab, remove the dust, etc. accumulated on the surface of the sensor.

When cleaning the sensor on the lower surface of the head is cleaned, move the carriage to the left end by the operations of step 1 of P.4-16 "Cleaning the Ink Head and the Area around It", and clean it.

The backside of the machine

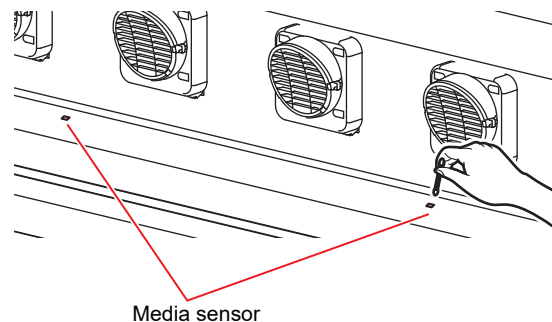

The lower surface of the head

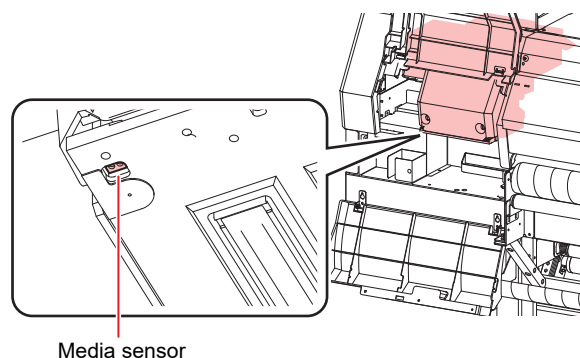

Cleaning folding bar (take-up side)

Remove ink blot etc. adhering to the folding bar located on the front surface of the machine and used at taking up the media.

Moisten soft cloth with water or waterish mild detergent, squeeze tightly and then wipe off.

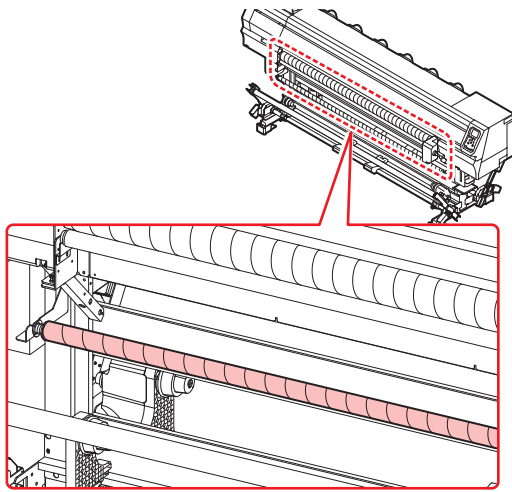

Cleaning the tension roller

Remove ink stain etc. adhering to the tension roller at the front side of the machine.

Moisten soft cloth with water or waterish mild detergent, squeeze tightly and then wipe off.

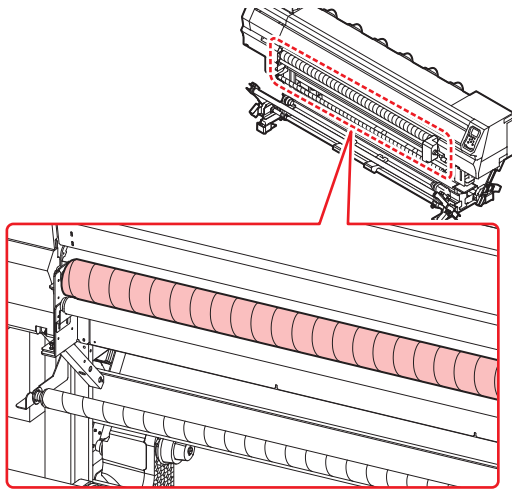

Cleaning the Ink receiving spacer

If you wish to remove the ink on the ink receiving spacer when replacing the media or during a similar operation, remove the spacer and clean it.

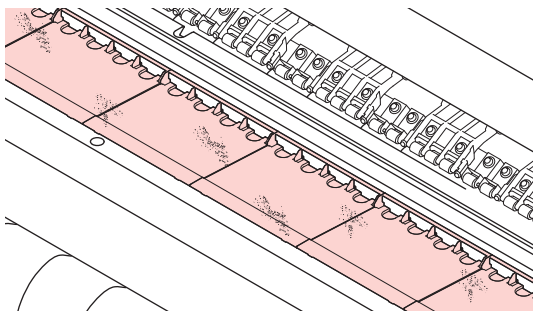

Cleaning the Platen



- Turn off the main power and unplug the power cable before maintenance.

Continuing to use the media while it is dirty may cause media to be fed incorrectly, or rubbing dirt or solid ink onto the head nozzle surface, resulting in discharge failure (nozzle clogging, deflection, etc.).

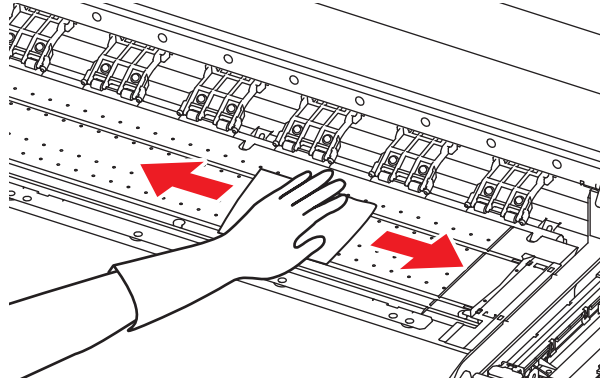

- Do not allow liquids to enter the machine. There is a risk of equipment failure, electric shock, or fire.



- If the dirt is noticeable, use a soft cloth soaked in a neutral detergent diluted with water, wrung out, and then wiped off.

- Before cleaning the platen, make sure that the platen has cooled adequately.



- The groove that slides the media press and the groove that cuts the media are particularly easy to collect dust. Please carefully remove the dust.

Tx300P-1800

When you print on an open weave fabric, some parts of ink pass through the fabric and adhere to the platen.

If you are worried about ink stain, clean ink adhering with water as below. (about once a week)

1 Remove the fabric retainer.

- Slide the fabric retainer to the edge of the platen, and remove it.

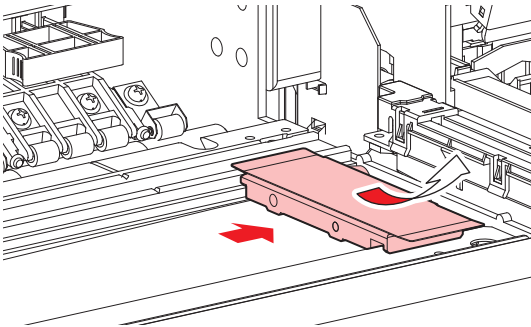

2 Clean the platen with water.

Important!

- Water on the platen flows into the waste ink tank on the left. Be careful not to let dirty water overflow out of the waste ink tank.
- Be careful not to flash a large amount of water. It may cause the overflow of water from inside the platen.

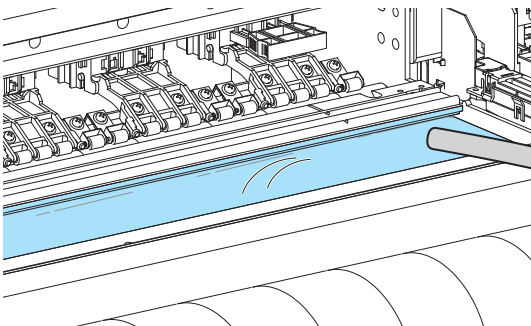

3 Wipe off dirty water remaining on the platen with a waste cloth etc.

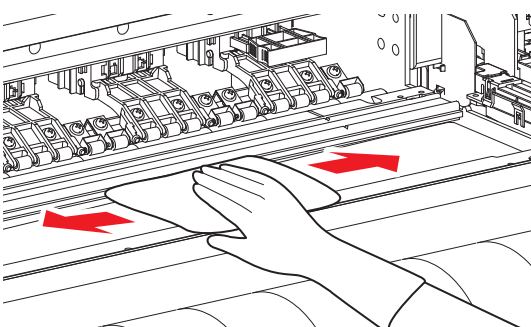

4 Remove the waste ink tank.



- Waste ink is equivalent to waste oil of industrial waste. Request an industrial waste disposal company for disposal of waste ink.

5 Attach the fabric retainer.

Tx300P-1800 MkII

● Cloth media platen

When you print on an open weave fabric, some parts of ink pass through the fabric and adhere to the platen.

If you are worried about ink stain, clean ink adhering with water as below. (about once a week)

1 Remove the fabric retainer.

- Slide the fabric retainer to the edge of the platen, and remove it.

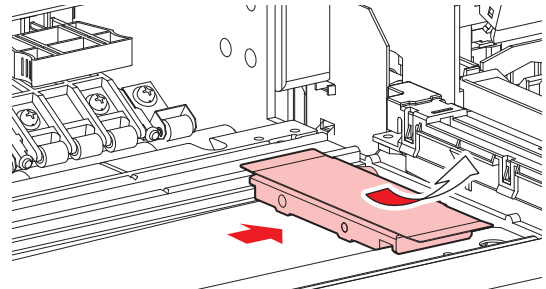

2 Wipe the platen using a cloth or towel soaked in water and tightly wrung out.



- Do not apply large amounts of water directly to the platen. If large amounts of water drip from the platen, this may cause the printer to fail.

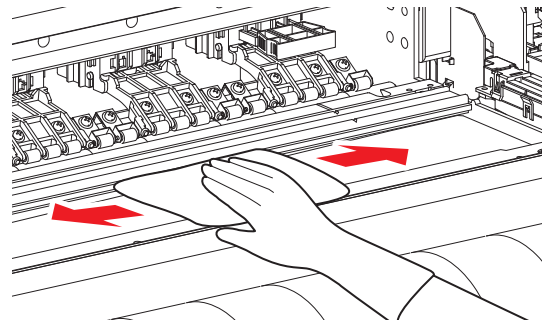

3 Attach the fabric retainer.

● Paper media platen

Wipe off conspicuous stains with a soft-hair brush, a dry cloth, a paper towel, etc.

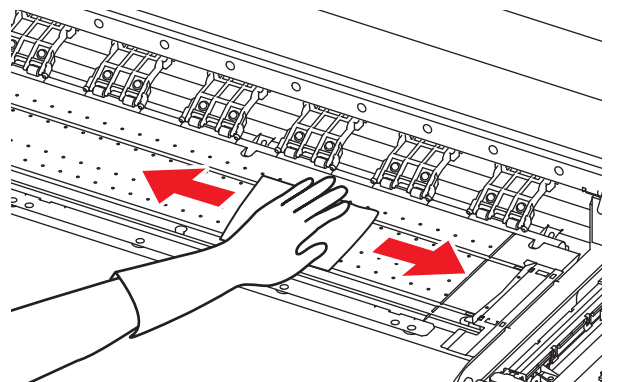

- When the platen is stained with ink, wipe it off with a paper towel containing a small amount of cleaning solution for maintenance.

Important!

- Because dust and dirt are easily accumulated in the slots for holding a media, be sure to clean these parts carefully.

Cleaning the Fabric Retainer / Media press

When you wish to clean dirt such as ink etc. adhered on the fabric retainer, you can remove the fabric retainer to clean it.

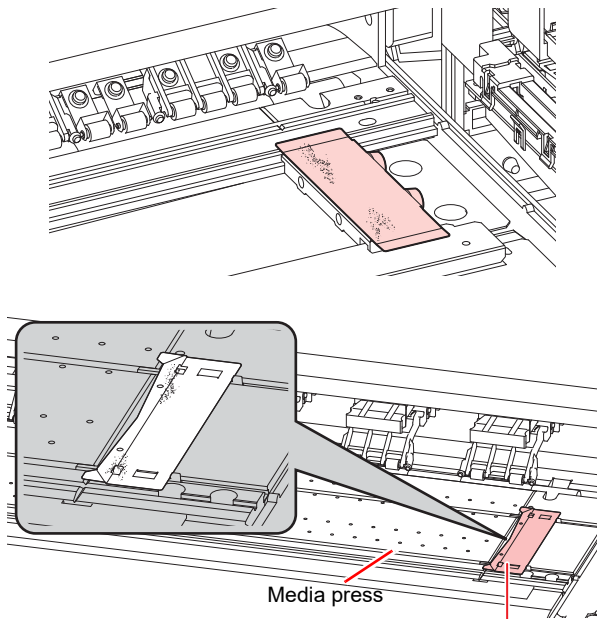

- Replace the fabric retainers and media presses with new ones if they are deformed or damaged.

Cleaning of grit roller

Remove pre-treatment agent or lint adhering to the grit roller with the resin brush periodically.

Important!

- Clean the grit roller periodically.
- In some cases and depending on media pre-treatment agent, if it is left on the grit roller, it may cause rust.
- If rust is generated on the grit roller, there is the fear that it cannot feed the media normally.

1

Turn the power switch OFF.

- Tilt the power switch to the "O" side.

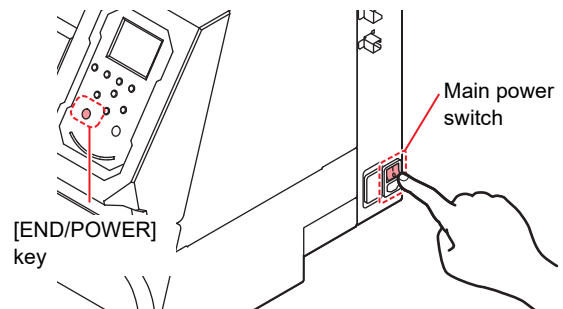

2

Open the front cover and raise the clamp lever.

3

Wipe the surface of the grit roller with the brush to remove blot.

- Wipe the surface of the grit roller for several times lightly.
- Brush the circumference of the grit roller while rotating the right side of it with your fingers.
- Wipe off dirty edge of the brush with a dry cloth.
- If the dirt is hard to remove, try putting some water on the brush.

Important!

- Be sure to clean the grit roller with resin brush. If you wipe off with a fabric or a paper, lint may adhere to concavity and convexity parts. In addition, if you use a hard metallic brush etc., it may scratch the grit roller.
- After brushing using water, feed some unnecessary media to remove any moisture.

The right side of the grit roller

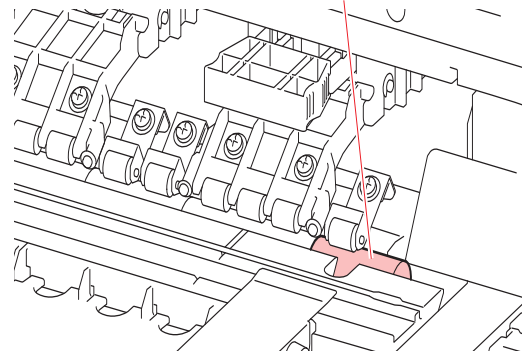

4**Remove blot on the pinch roller surface.**

- Wipe the pinch roller surface with a cloth etc. to remove ink blot.

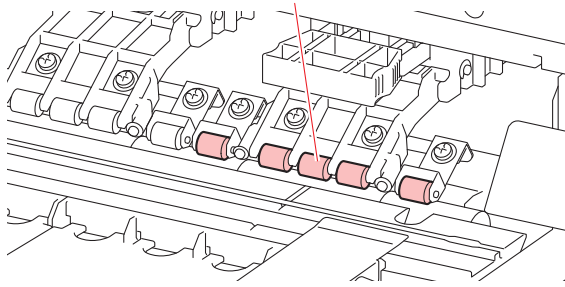
Remove ink stain.

- The pinch rollers are consumable items. Replace if they are excessively dirty or damaged.

About MAINTENANCE MENU

This provides various settings for doing maintenance on the machine.
The following items can be set in Maintenance settings.

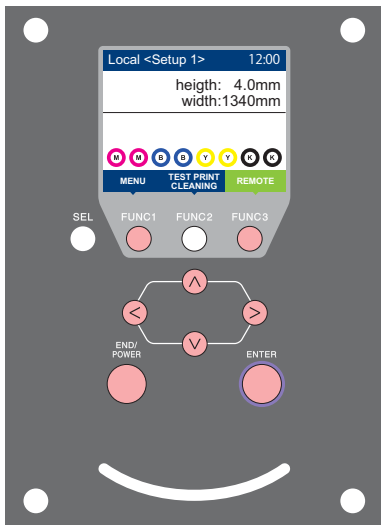

- FUNC1** : Press this to select MAINTENANCE MENU, or to switch to the previous screen.
- FUNC2** : Press this to use the maintenance function.
- FUNC3** : Press this to switch to the next screen.
- ▲ ▼** : Use these to select a setting item.
- ENTER** : Press this to confirm a setting, etc..

◆ MAINTENANCE MENUs at-a-glance

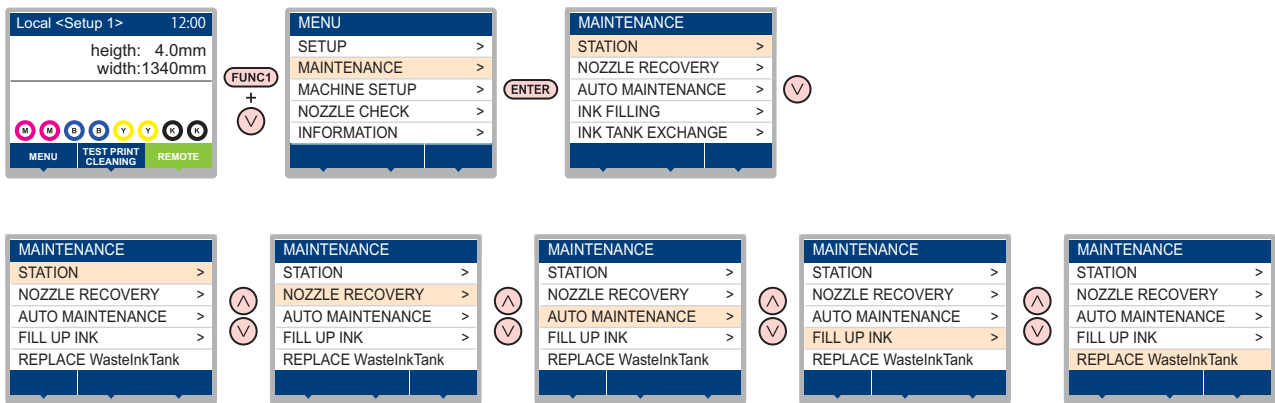

◆ Screen transition when **FUNC2** is pressed

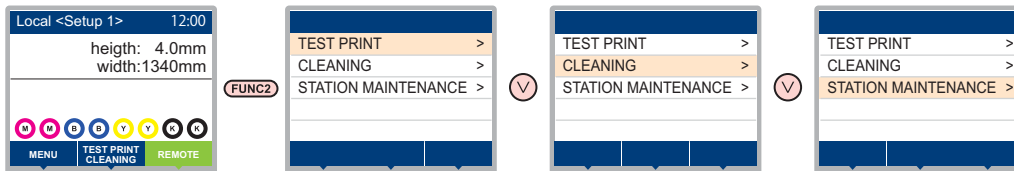

MAINTENANCE MENU at-a-glance

Item	Set value	Meaning	
STATION MAINTENANCE	For carrying out maintenance on the carriage and station periphery.		
	CARRIAGE OUT (☞ P.4-10)	_____	Moves the carriage out, for carrying out cleaning of the cap periphery, head, wipers, etc.
	NOZZLE WASH (☞ P.4-12)	1 to 99 min	Soaks the nozzle surfaces in maintenance cleaning fluid, for carrying out recovery from nozzle clogging or bent.
	DISWAY WASH (☞ P.4-13)	_____	Executes washing of the suction pump tubes.
	CUSTODY WASH (☞ P.4-14)	1 to 99 min	Carried out when the machine is going to be out of use for an extended period. Washes the nozzles and tubes beforehand, to keep the machine in fine condition.
	WIPER EXCHANGE (☞ P.4-23)		Used when replacing the wiper. If the wiper is replaced, the number of times the wiper was used that is managed in this device is reset.
NOZZLE RECOVERY (☞ P.4-18)	For printing using another nozzle, if nozzle wash and so forth fail to effect recovery from nozzle missing, etc.		
	PRINT		Used to print a pattern and to check and/or register clogged nozzles.
	ENTRY		Registers the faulty nozzle identified by "PRINT".
	RESET		Resets a registered faulty nozzle.
	CHECK		Checks recoverable printable conditions.
	TEST PRINT	ON/OFF	Enables or disables the configuration of the nozzle recovery function during a test print.
AUTO MAINT. (☞ P.4-21)	For having the various maintenance functions executed automatically. Set the execution interval for each maintenance function.		
	REFRESH		For setting the activation interval for refresh.
	PUMP TUBE CLEANING	The setting is different depending on your ink type.	For setting the activation interval for the ink discharge passage cleaning.
	CLEANING		INTERVAL
	TYPE	NORMAL/ HARD* ¹	Select the cleaning type for head cleaning.
FILL UP INK (☞ P.4-22)	Supplies ink to correct nozzle clogging.		
REPLACE WasteInkTank (☞ P.4-24)	Resets or corrects the used count for the waste ink tank.		

*1. "Soft" can also be set when reactive dye ink Rc 400 or Rc 500 is used.

Maintaining the Capping Station

Maintain the ink cap, wiper, etc. located in the capping station. (SATION MAINT.)

- Important!** • To keep the nozzle status normal, perform wiper cleaning frequently.

The ink cap and wiper function as follows.

- **Wiper** : It wipes off ink sticking to the head nozzles.
- **Ink cap** : It prevents the head nozzles from clogging due to dryness.

As the machine is used repeatedly, the wiper and ink cap gradually become dirty with ink, dust, etc. If nozzle missing cannot be corrected even after head cleaning (P.2-29) has been performed, use a Cleaning Liquid 03 MAINTENANCE KIT and clean stick.

Tools required for Maintenance	
<ul style="list-style-type: none"> • Cleaning Liquid 03 MAINTENANCE KIT (ML003-Z-K1) • Cleaning Liquid 12 MAINTENANCE KIT (C-ML012-Z-K1-1-KW : Hybrid type including TP400 pigment ink.) 	
<ul style="list-style-type: none"> • Clean stick (SPC-0527) 	
<ul style="list-style-type: none"> • Gloves 	<ul style="list-style-type: none"> • Safety glasses



- Be sure to wear the included safety glasses and gloves when maintaining the capping station. Otherwise, you may get ink in your eyes.
- Do not move the carriage out of the capping station by hand. When it is desirable to move the carriage, press [FUNC1] key to execute the carriage-out. (P.4-10 Steps 1 to 2)

Cleaning the Wiper and Cap

It is recommended that the wiper and cap be cleaned frequently in order to maintain the high image quality of the machine and keep the machine itself in good working order. When cleaning the twin wiper, follow the procedure below.

- Important!** • Replace the wiper with a new one when it is extremely dirty or bent. (P.4-23)
- When cleaning the wiper, be careful that lint from the clean stick does not get left on the wiper. Remaining lint may cause image quality to deteriorate.

- 1** Press **FUNC1 (MENU)** → **ENTER** in LOCAL.
 - MAINTENANCE MENU will be displayed.

- 2** Press the **ENTER** key twice.
 - The carriage moves onto the platen.

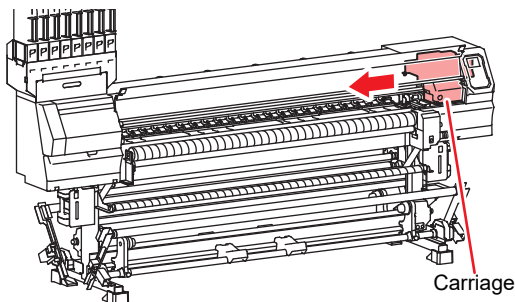

- 3** Open the front cover.

- 4** Remove the wiper.
 - Pull out the wiper by holding the protrusions at its both ends.

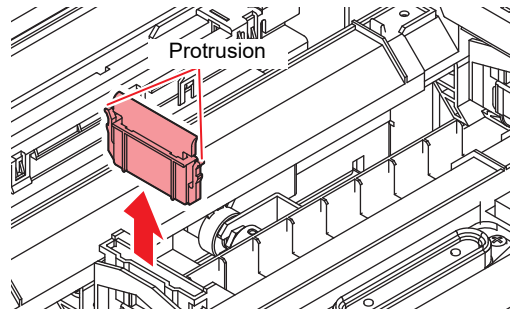

- For the twin wiper

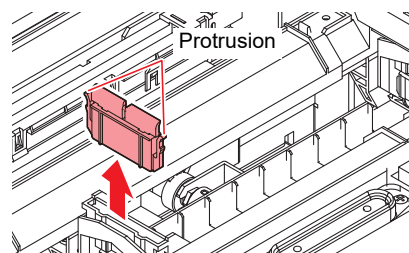

- 5** Clean the wiper and bracket.
 - Wipe off the ink sticking to the wiper and bracket with a clean stick dipped in cleaning solution for maintenance. Wipe off so that cleaning solution for maintenance will not remain.

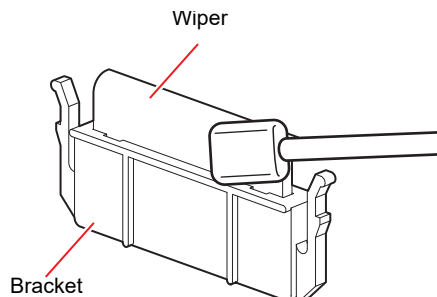

- For the twin wiper

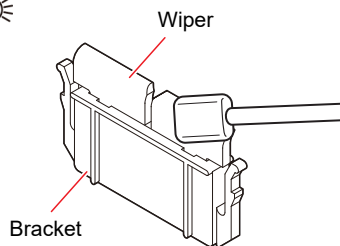

6 Clean the wiper cleaner.

- Wipe off the ink sticking to the wiper cleaner with a clean stick dipped in cleaning solution for maintenance. Wipe off so that cleaning solution for maintenance will not remain.

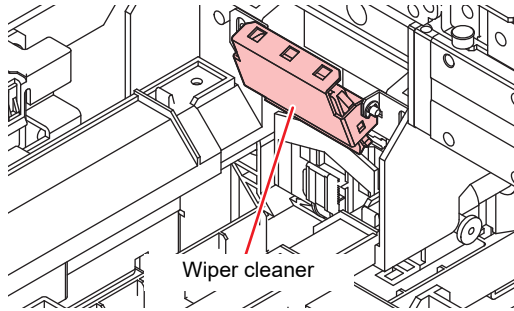

- If there is a large amount of ink in the absorbent case, wipe it away using water-absorbent paper or the like.

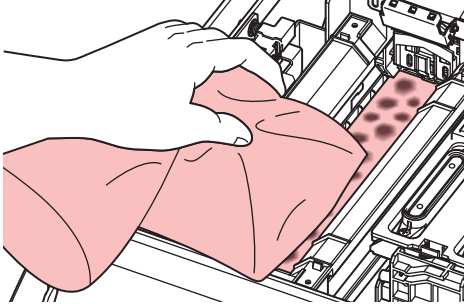

- Do not remove the wiper cleaner from the bracket.
- Only clean the front surface on the wiper cleaner's wiper. (You do not need to clean the rear surface.)
- Do not remove the absorbent material in the absorbent case.
- After the wiper cleaner cleaning, make sure that the cleaner is not facing up.

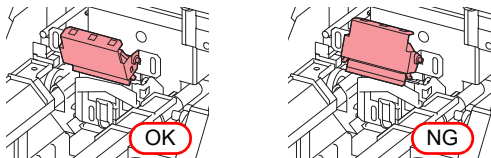

7 Set the wiper at the original position.

- Insert the wiper by holding the protrusions at its both ends.

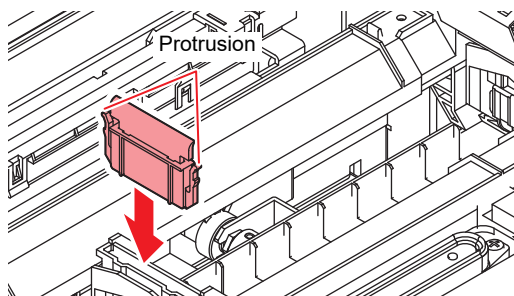

8 Clean the cap rubber.

- Wipe off the ink sticking to the cap rubber with a clean stick dipped in maintenance solution for maintenance. Wipe off so that maintenance solution for maintenance will not remain.

Cap rubber

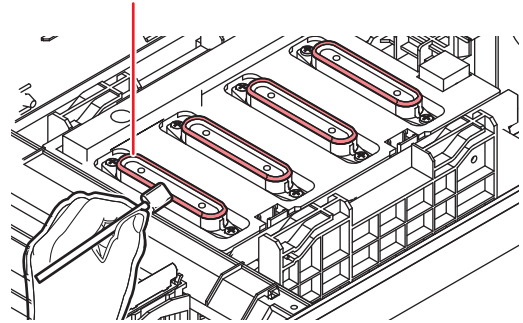

Important!

- After cleaning the cap rubber, check to make sure the cap slider is not tilted. If it is tilted, move the slider block left and right to fix its tilt.

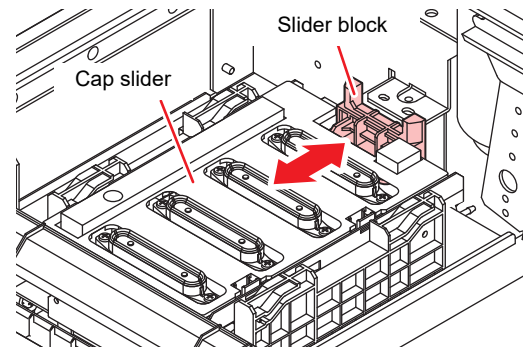

9 Press the **ENTER** key after the cleaning.

10 Close the front cover then press the **ENTER** key.

- After its initial operation, the machine returns to step 1.

Cleaning the Cap Absorber

It is recommended that the wiper and cap be cleaned frequently in order to maintain the high image quality of the machine and keep the machine itself in good working order.

- 1 Press **FUNC1 (MENU)** → **ENTER** in LOCAL.
 - MAINTENANCE MENU will be displayed.

- 2 Press the **ENTER** key twice.
 - The carriage moves onto the platen.

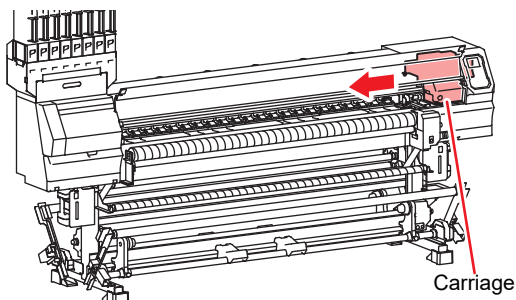

- 3 Open the front cover.

- 4 Cleaning Cap absorber.
 - Wipe off the ink adhering to the cap absorber with a clean stick or nonwoven towel dipped in the maintenance cleaning solution.
 - Wipe off so that maintenance solution for maintenance will not remain.

Cap absorber.

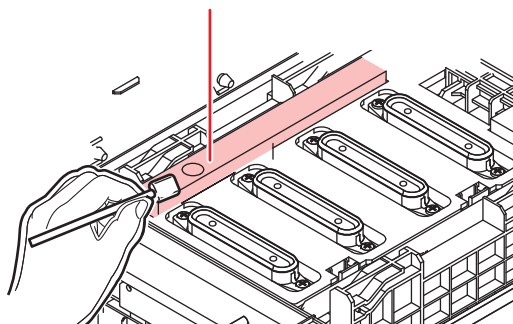

- 5 Press the **ENTER** key after the cleaning.

- 6 Close the front cover then press the **ENTER** key.
 - After its initial operation, the machine returns to step 1.

Washing the Head Nozzle

- 1 Press **FUNC1 (MENU)** → **ENTER** in LOCAL.
 - MAINTENANCE MENU will be displayed.

- 2 Press **ENTER** .
 - "STATION" will be selected.

- 3 Press **▲▼** to select "NOZZLE WASH", and press the **ENTER** key.

- 4 Press **▲▼** to select the washing head, and press the **ENTER** key.

- 5 When "WIPER CLEANING" appears on the display, open the front cover.

- 6 Clean the wiper and the bracket, and press the **ENTER** key.

- (1) Open the right maintenance cover then pull out it by holding protrusions at both ends of the wiper.
- (2) Clean the wiper and bracket with a clean stick dipped in maintenance washing liquid for maintenance.
 - Wipe off so that maintenance washing liquid for maintenance will not remain.
- (3) Insert it in the original position by holding the protrusions at both ends of the wiper.

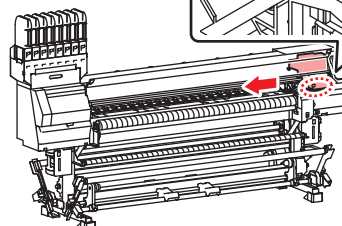
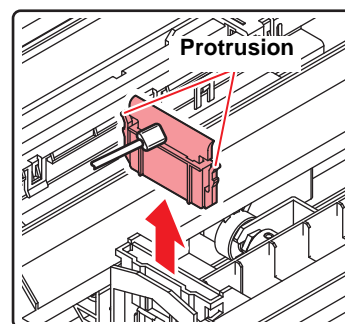

Important!

- After cleaning the wiper, check to make sure the cap slider is not tilted. If it is tilted, move the slider block left and right to fix its tilt.

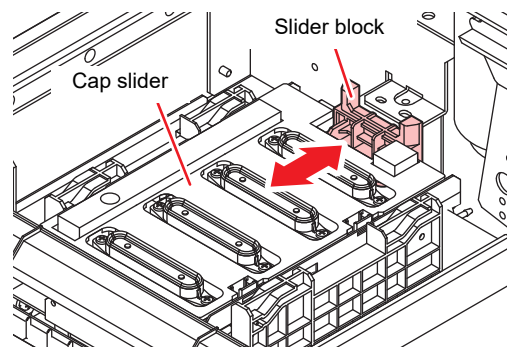

- 7 When cleaning of the cap rubber is complete, close the front cover and press the **ENTER** key.

- Wipe off the ink sticking to the cap rubber with a clean stick dipped in maintenance washing liquid for maintenance.
- Wipe off so that maintenance washing liquid for maintenance will not remain.
- At this time, the discharge passage is cleaned automatically.

8 Fill up the cap with cleaning solution for maintenance.

- If the cleaning solution cartridge is usable, maintenance solution is automatically filled.
- When the cap is filled with cleaning solution, the display will prompt you to check the cleaning solution.

Important!

- If the front cover is not closed, the cleaning solution will not be automatically filled. If the front cover is open, be sure to close it.



- If the cleaning cartridge is not valid, the cleaning solution will not be automatically filled to the cap. Open the front cover and use a dropper to fill the maintenance cleaning solution in the cap to just before it overflows. Once the cleaning solution is full, begin from Step 9.

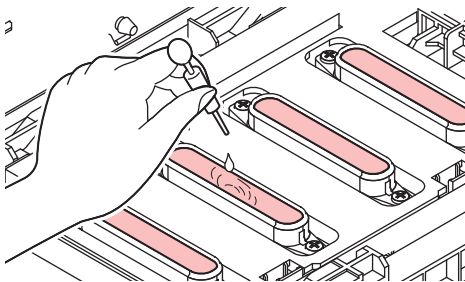

9 If a message is displayed, open the front cover and check the amount of cleaning solution in the cap.

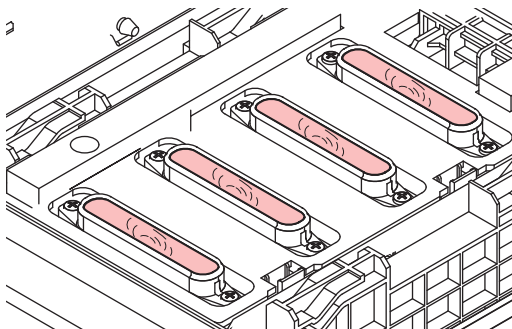

Important!

- If the solution does not fill up the cap, use a dropper to fill the maintenance cleaning solution in the cap to just before it overflows.

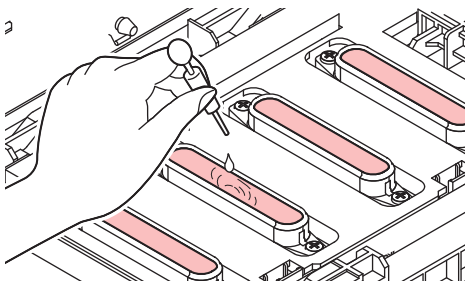

10 Close the front cover, and press the **ENTER** key.

11 Press **▲▼** to set the time for the maintenance washing liquid to be left as it is, and press the **ENTER** key.

- **Set value** : 1 to 99 minutes (Unit: minute)
- The maintenance washing liquid filled in the cap is absorbed.
- "Please Wait" will be displayed in the display until the time you set has elapsed.

Important!

- When nozzle missing is not cleared even after nozzle recovery (P.4-18) or this washing is carried out several times, contact the distributor in your region or our service office.

Washing the Ink Discharge Passage

Wash the ink discharge passage regularly (about once a week) to prevent the head nozzles from clogging due to ink coagulation inside the passage.

Important!

- Before washing the ink discharge passage, make sure that the maintenance washing liquid is set. If the maintenance washing liquid is not set, washing operation will not be conducted and the passage could be clogged.

1 Press **FUNC1 (MENU) ▼▶▶** in LOCAL.

- MAINTENANCE MENU will be displayed.

2 Press the **ENTER** key.

- "STATION" will be selected.

3 Press **▲▼** to select "DISWAY WASH", and press the **ENTER** key.

4 Press **▲▼** to select the washing head, and press the **ENTER** key.

5 Fill up the cap with cleaning solution for maintenance.

- If the cleaning solution cartridge is usable, maintenance solution is automatically filled.

Important!

- If the front cover is not closed, the cleaning solution will not be automatically filled. If the front cover is open, be sure to close it.



- If the cleaning cartridge is not valid, the cleaning solution will not be automatically filled to the cap. Open the front cover and use a dropper to fill the maintenance cleaning solution in the cap to just before it overflows. Once the cleaning solution is full, begin from Step 7.

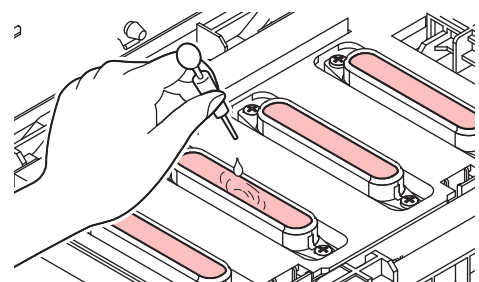

- 6** If a **END** message is displayed, open the front cover and check the amount of cleaning solution in the cap.

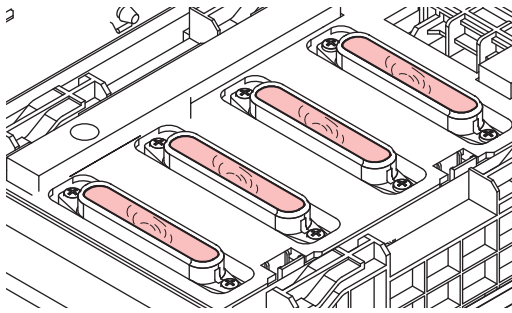

Important! • If the solution does not fill up the cap, use a dropper to fill the maintenance cleaning solution in the cap to just before it overflows.

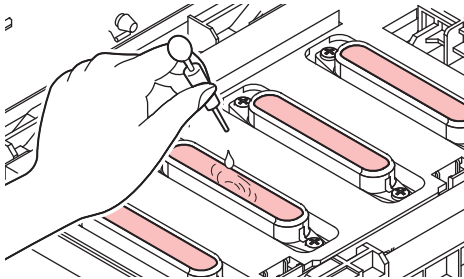

- 7** Close the front cover, and press the **ENTER** key.

When the Machine Is Not Used for a Long Time

When the machine is not going to be used for a week or more, use the cleaning function for custody to clean the head nozzles and ink discharge passage. After this, keep the machine in custody.

Important! • Use the machine with always turning "ON" the main power. The function preventing nozzle clogging operates automatically to protect the head of the nozzle.
• The head nozzle may result in nozzle clogging if the main power switch is left OFF for a long time.

Check the items on the right beforehand.

Is **[NEAR END]** or **[INK END]** displayed?

- The cleaning solution or ink is absorbed when the nozzles are washed.
At this time, if the state of "no ink" or "almost no ink" is detected, the nozzle washing operation cannot start.
- Replace the ink IC chip with another from which the state of "almost no ink" or "no ink" is not detected.



• When the warning messages "Check waste ink" are indicated, check the waste ink tank, and operate it, referring to P.4-24 "If a Waste Ink Tank Confirmation Message Appears" according to the situation.

- 1** Press **FUNC1 (MENU)** → **ENTER** in **LOCAL**.

• MAINTENANCE MENU will be displayed.

- 2** Press the **ENTER** key.

• "STATION" will be selected.

- 3** Press **▲** **▼** to select "**CUSTODY WASH**", and press the **ENTER** key.

• Carriage will move onto the platen.

- 4** When "**WIPER CLEANING**" appears on the display, open the front cover.

- 5** Clean the wiper and the bracket.

- (1) Open the front cover then pull out it by holding projections at both ends of the wiper.
- (2) Clean the wiper and bracket with a clean stick dipped in cleaning solution for maintenance. Wipe off so that cleaning solution for maintenance will not remain.
- (3) Insert it in the original position by holding the projections at both ends of the wiper.

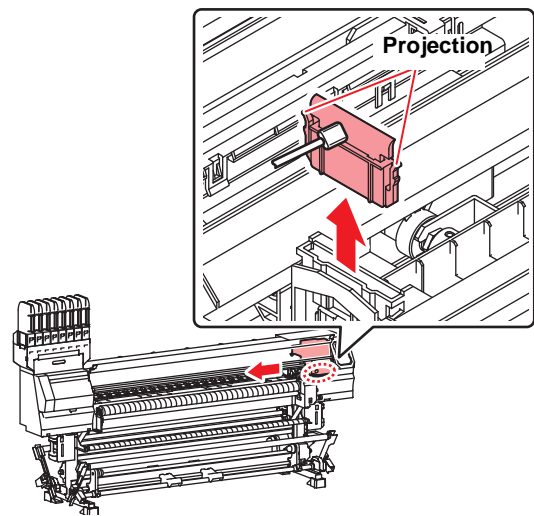

- 6** Press the **ENTER** key.

Important! • Until wiper cleaning is completed, **[COMPLETED (NEXT): ENT]** is displayed on the screen. After the work up to the step 5 is completed, press the **[ENTER]** key. If you press the **[ENTER]** key before cleaning is completed, the machine moves to the next washing procedure.

7 Clean the cap rubber.

- Wipe off the ink sticking to the cap rubber with a clean stick dipped in maintenance solution for maintenance.
- Wipe off so that maintenance solution for maintenance will not remain.
- At this time, the discharge passage is cleaned automatically.

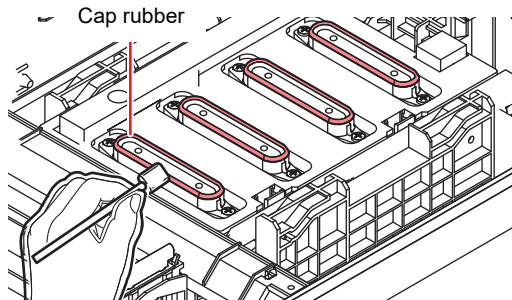

- Important!**
- After cleaning the cap rubber, check to make sure the cap slider is not tilted. If it is tilted, move the slider block left and right to fix its tilt.

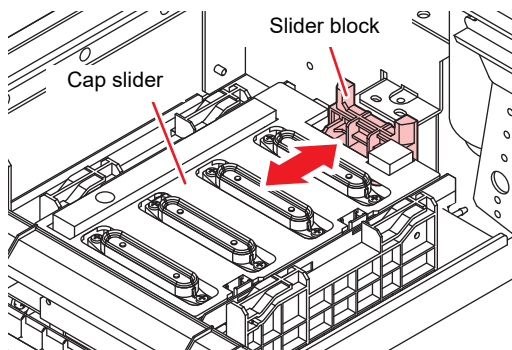
**8 Close the front cover and press the **ENTER** key.****9 Fill up the cap with cleaning solution for maintenance.**

- If the cleaning solution cartridge is usable, maintenance solution is automatically filled.
- When the cap is filled with cleaning solution, the display will prompt you to check the cleaning solution.

- Important!**
- If the front cover is not closed, the cleaning solution will not be automatically filled. If the front cover is open, be sure to close it.

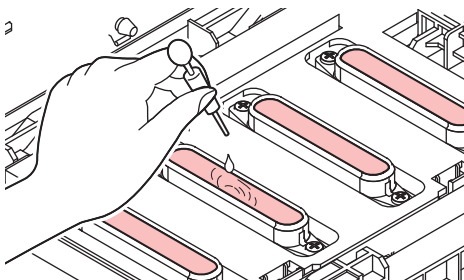
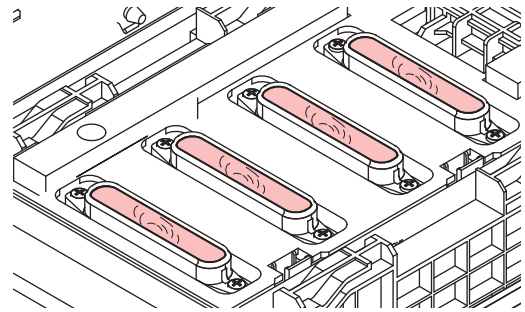

- If the cleaning cartridge is not valid, the cleaning solution will not be automatically filled to the cap. Open the front cover and use a dropper to fill the maintenance cleaning solution in the cap to just before it overflows. Once the cleaning solution is full, begin from Step 11.

**10 If a message is displayed, open the front cover and check the amount of cleaning solution in the cap.**

- Important!**
- If the solution does not fill up the cap, use a dropper to fill the maintenance cleaning solution in the cap to just before it overflows.

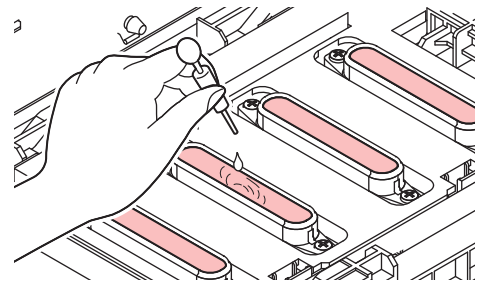
**11 Close the front cover, and press the **ENTER** key.****12 Press **▲** **▼** to set the time for the cleaning solution to be left as it is.**

- Set Value: 1 to 99 min (by the unit of 1 min)

13 Press the **ENTER key.**

- The nozzles are washed.
- When the nozzles have been completely washed, the head moves to the maintenance position.

14 Fill up the cap with cleaning solution for maintenance.

- If the cleaning solution cartridge is usable, maintenance solution is automatically filled.

- Important!**
- If the front cover is not closed, the cleaning solution will not be automatically filled. If the front cover is open, be sure to close it.



- If the cleaning cartridge is not valid, the cleaning solution will not be automatically filled to the cap. Open the front cover and use a dropper to fill the maintenance cleaning solution in the cap to just before it overflows. Once the cleaning solution is full, begin from Step 16.

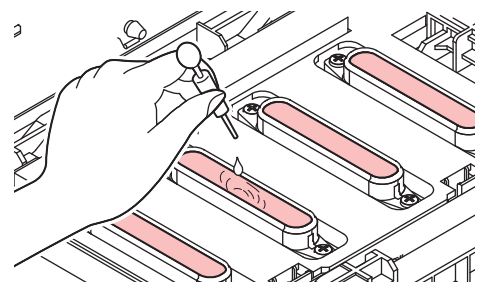

15 If a END message is displayed, open the front cover and check the amount of cleaning solution in the cap.

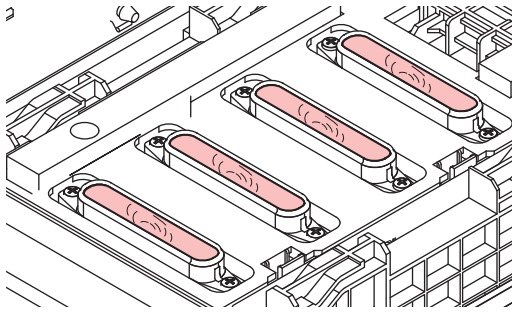

Important! • If the solution does not fill up the cap, use a dropper to fill the maintenance cleaning solution in the cap to just before it overflows.

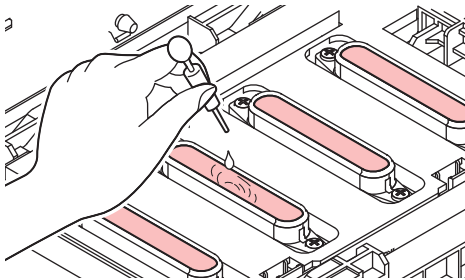

16 Close the front cover and press the **ENTER** key.

• After its initial operation, the machine returns to step 2.

Cleaning the Ink Head and the Area around It

Because the ink head employs a very precise mechanism, due care needs to be taken when it is cleaned.

Using a clean stick, etc., rub off gelatinous ink or dust that may stick to the lower part of the slider and the area around the ink head. In doing so, never rub the nozzles of the head.

Tools required for cleaning

- | | |
|--------------------------|----------|
| • Clean stick (SPC-0527) | • Gloves |
| • Safety glasses | |



- Be sure to wear the included safety glasses and gloves when cleaning the area around the ink head. Otherwise, you may get ink in your eyes.
- The ink contains organic solvent. If you get the ink on your skin or in your eyes, wash it away with plenty of water immediately.

Cleaning around the Ink Head

1 Press **FUNC1** (MENU) → **ENTER** in LOCAL.

- MAINTENANCE MENU will be displayed.

2 Press the **ENTER** key twice.

- "CARRIAGE OUT" will be selected.

3 Press **▲** **▼** to select "HEAD MAINTENANCE", and press the **ENTER** key.

- Carriage will move to the left end of this machine.

4 Open the maintenance cover.

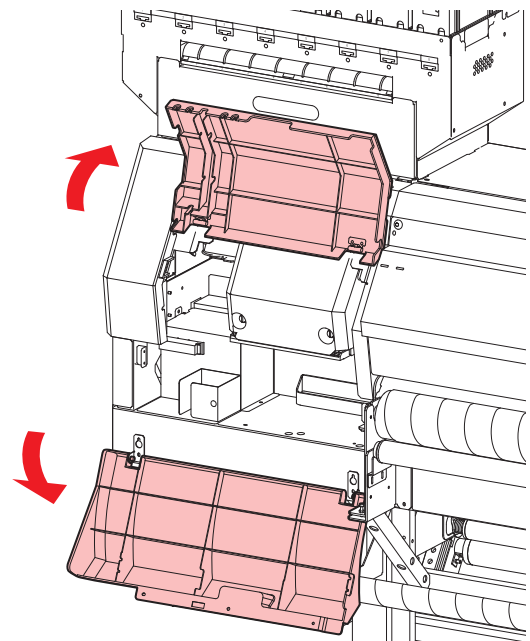

5 Clean the side of the head, slider bottom, and carriage bottom.

- Wipe the ink accumulated on the side of the head, the bottom of the slider, and the bottom of the carriage with a clean stick or nonwoven towel dipped in the maintenance cleaning solution.
- Never rub the nozzles.

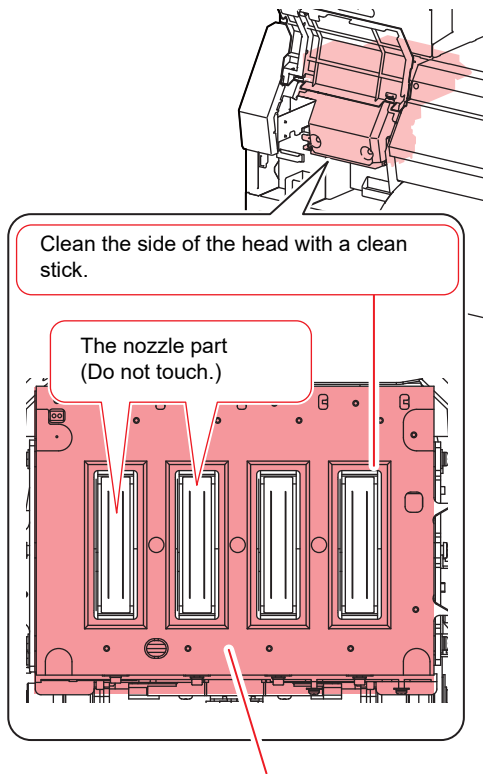

Clean with a clean stick or nonwoven towel.

6 Press the **ENTER** key after the cleaning.

7 Close the maintenance cover, and press the **ENTER** key.

- After its initial operation, the machine returns to LOCAL.

Clean the edge of the head nozzle surface

Clean when using a hybrid ink (Sb411 + Sb420, Sb411 + TP400).

Using a clean stick, etc., rub off gelatinous ink or dust that may stick to the edge of the head nozzle surface.

1 Press **FUNC1** (MENU) \rightarrow \downarrow \rightarrow **ENTER** in LOCAL.

- MAINTENANCE MENU will be displayed.

2 Press the **ENTER** key twice.

- "CARRIAGE OUT" will be selected.

3 Press \uparrow \downarrow to select "HEAD MAINTENANCE", and press the **ENTER** key.

- Carriage will move to the left end of this machine.

4 Open the maintenance cover.

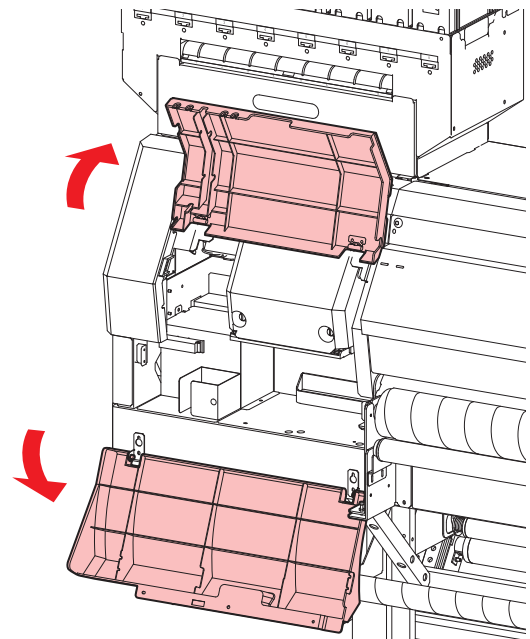

5 Clean the edge of the head nozzle surface with a clean stick.

- Wipe off the ink accumulated on the edge of the head nozzle surface of the heads 3 and 4 (the shaded area in the figure below) with a clean stick soaked in maintenance cleaning solution.
- Heads 1 and 2 are not subject to cleaning.
- Never touch or rub the nozzles.

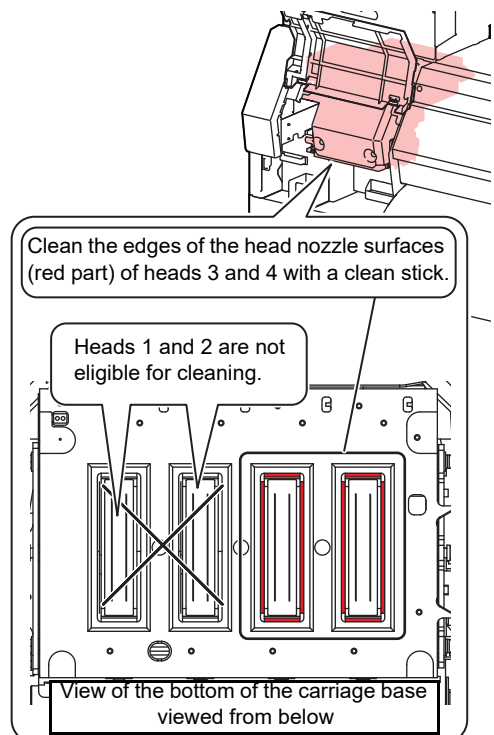

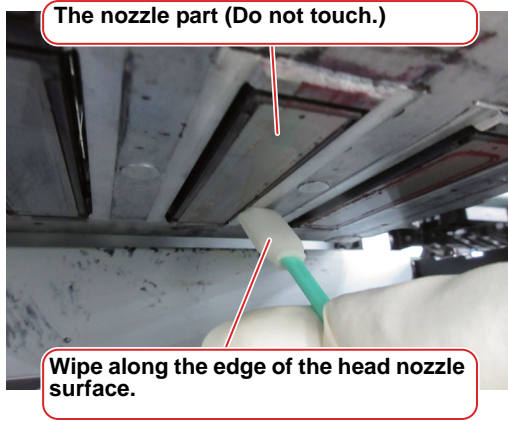

Important!

- Use the cleaning liquid dedicated for the ink being used. (☞ P.4-3)
- Do not use the dirty part of the clean stick for other edges.
- Move the clean stick round trip two or three times in order from the right side, left side, front side, and back side of the head nozzle to clean.
- It is effective to use each part of the clean stick as shown below.

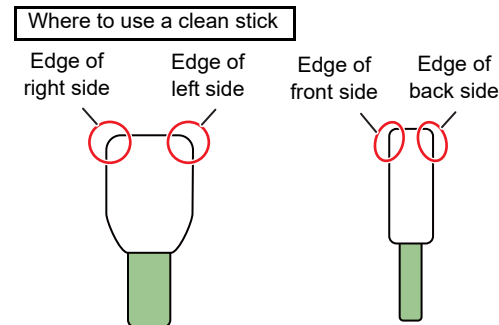
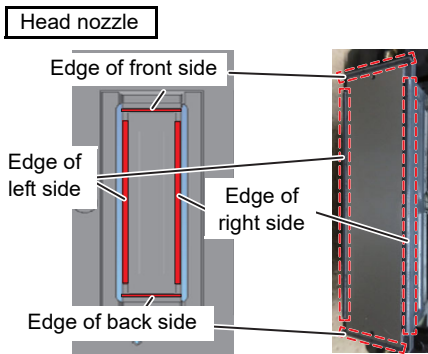

6 Press the **ENTER** key after the cleaning.

7 Close the maintenance cover, and press the **ENTER** key.

- After its initial operation, the machine returns to LOCAL.

Nozzle Recovery Function

NOZZLE RECOVERY: When nozzles missing can not be improved at specific points, other good nozzles can be used as alternatives for printing.

- 1** Press **FUNC1 (MENU)** → **▼** → **ENTER** in LOCAL.
 - MAINTENANCE MENU will be displayed.
- 2** Press **▲▼** to select “**NOZZLE RECOVERY**”, and press the **ENTER** key.
- 3** Press the **ENTER** key twice.
 - Printing of the nozzle pattern will start.
 - Select “ENTRY” then “Move to select of the Nozzle line (Step 4) without drawing a pattern”

Overhead view

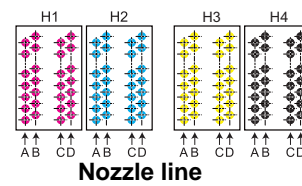

Nozzle pattern of Head 1

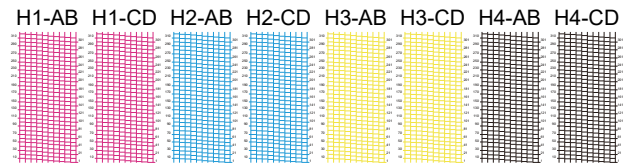

Important!

- When using leaf media, set a media of more than A3 size put horizontally. If a media with narrow width is set, printing will only be conducted to midway.

4 Select the Nozzle line that needs **NOZZLE RECOVERY** by pressing **▲▼**, and press the **ENTER** key.

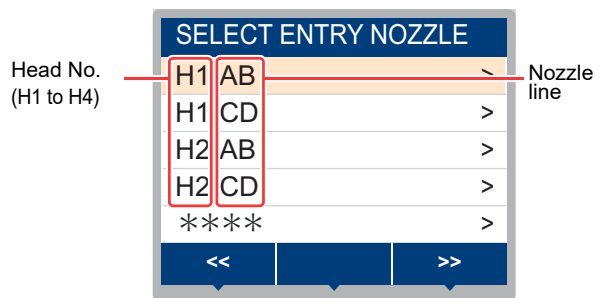

5 Register the Nozzle number that needs NOZZLE RECOVERY and press the

ENTER key.

- (1) Select the registration number from 1 to 10 by pressing [**▲**][**▼**] and press the [**ENTER**] key.
- (2) Register the nozzle number that needs recovery by pressing [**▲**][**▼**] and press the [**ENTER**] key.

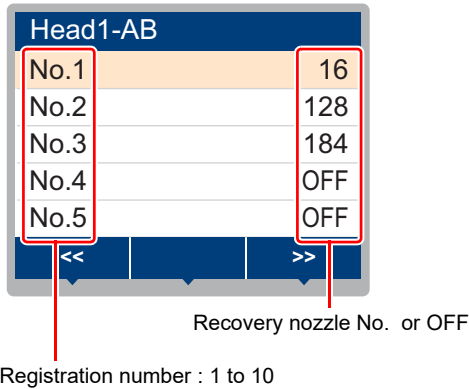

Example of nozzle to be recovered

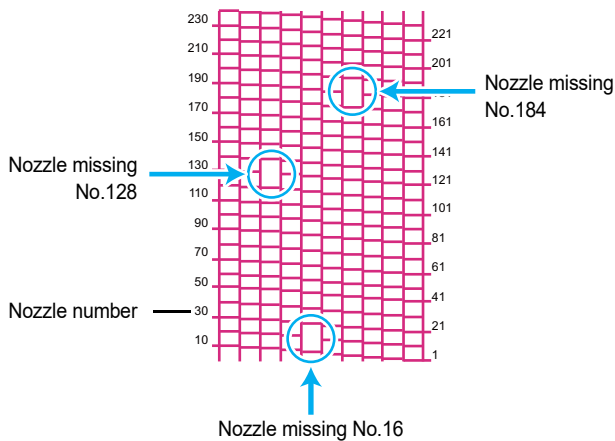

Registration number	Recovery Nozzle No.	State
1	16	Target for nozzle recovery
2	128	Target for nozzle recovery
3	184	Target for nozzle recovery
4	OFF	No registration
5	OFF	No registration

6 Press the **END/POWER** key several times to end the setting.

Important!

- Up to 10 nozzles can be registered per 1 nozzle line.
- Even if you use this function, time required for drawing does not change.
- When printing has been done with the lowest path, nozzle recovery is not reflected.

Reset the set value

- 1 Press **FUNC1** (MENU) → [**▼**] → [**ENTER**] in LOCAL.
 - MAINTENANCE MENU will be displayed.
- 2 Press [**▲**][**▼**] to select “NOZZLE RECOVERY”, and press the [**ENTER**] key.
- 3 Press [**▲**][**▼**] to select “RESET”, and press the [**ENTER**] key.
- 4 Press [**▲**][**▼**] and **FUNC1** (<<) **FUNC3** (>>) to select the Nozzle line that need reset, and press the [**ENTER**] key.
 - A reset confirmation message will be displayed.
- 5 Press the [**ENTER**] key.
- 6 Press the **END/POWER** key several times to end the setting.

Check the condition for which nozzle recovery cannot be performed

- 1 Press **FUNC1** (MENU) → [**▼**] → [**ENTER**] in LOCAL.
 - MAINTENANCE MENU will be displayed.
- 2 Press [**▲**][**▼**] to select “NOZZLE RECOVERY”, and press the [**ENTER**] key.
- 3 Press [**▲**][**▼**] to select “CHECK”, and press the [**ENTER**] key.
 - Judgement Condition input screen will be displayed.

Judgement Condition	
Resolution	720 x 720
PASS	8
Scan Speed	NORMAL
MAPS 4	>
OVER PRINT	1



- When using two types of ink with the hybrid function, please select the type of ink to check.

Judgement Condition	
Select ink type	
: Sb420	

4 Adapt each item of the judgment conditions to your current state.

- (1) Press [▲][▼] to select the setting item, and press the [ENTER] key.
- (2) Press [▲][▼] to select the setting value, and press the [ENTER] key.
- (3) Repeat steps (1) and (2), and set all of the items.

5 Press **FUNC2**.

- Begin to check if nozzle recovery at the set printing conditions can be done.
- When the check is completed, the judgment result is displayed on the screen.

If the nozzle recovery possible



If the nozzle recovery is not possible

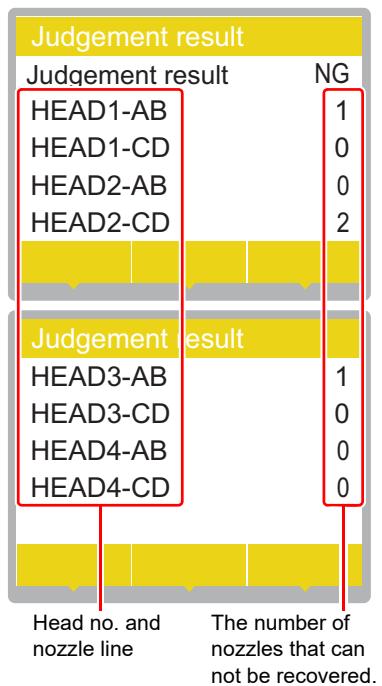

6 Press **END/POWER** several times to end the setting.

Enabling or disabling nozzle recovery during a test print

To enable the nozzle recovery function during a test print (☞ P.2-28), turn the following settings “ON”, and register the numbers of the nozzles for recovery in “Nozzle Recovery Function” on P.4-18.

- 1** Press **FUNC1 (MENU)** → **▼** → **ENTER** in LOCAL.
 - MAINTENANCE MENU will be displayed.
- 2** Press **▲▼** to select “NOZZLE RECOVERY”, and press the **ENTER** key.
- 3** Press **▲▼** to select “TEST PRINT”, and press the **ENTER** key.
- 4** Press **▲▼** to select ON/OFF, and press the **ENTER** key.
- 5** Press the **END/POWER** key several times to end.

Automatic Maintenance Function

To use this machine comfortably, you can set various maintenances to be performed automatically.

Here, set performing intervals of various automatic maintenances.

You can prevent troubles such as ink clogging by performing automatic maintenance periodically (automatic maintenance function).

For the auto maintenance functions, the following items can be set:

- Important!**
- When you perform maintenance manually, after manual maintenance is completed and when time set with the automatic maintenance function has passed, maintenance starts automatically.
 - If using the Automatic Maintenance Function, make sure that the maintenance washing liquid is set. If the maintenance washing liquid is not set, tube washing operation will not be regularly conducted and the passage could be clogged.

Function name	Descriptions
REFRESH	The interval between each refreshing operation is set.
PUMP TUBE CLEANING	The activation interval for tube washing is set.
CLEANING (Interval)	The interval between each cleaning operation is set.
CLEANING (Type)	The cleaning type is set.
NOZZLE WASH	Setting for the action can not be changed.

- Important!**
- If the "Check waste ink" warning message is displayed, the operation set in the auto maintenance function is not carried out. Perform the operations of P.4-24 "Replace the waste ink tank with another" if required.
 - When the power switch on the front of the machine is turned off, check the waste ink tank.
 - With hybrid printing, ink is consumed for periodic cleaning even for heads that are not in use.

Setting the Refreshing Intervals

The interval between each operation of ejecting a small amount of ink from the nozzles to prevent nozzle clogging is set.

- 1 Press **FUNC1** (**MENU**) → **▼** → **ENTER** in LOCAL.
 - MAINTENANCE MENU will be displayed.
- 2 Press **▲** **▼** to select "AUTO MAINTENANCE", and press the **ENTER** key.
- 3 Press the **ENTER** key.
 - "REFRESH" will be selected.
- 4 Press **▲** **▼** to set the refreshing interval, and press the **ENTER** key.
 - Set value : The set value will differ according to the ink type being used.
- 5 Press the **END/POWER** key several times to end the setting.

Setting the Tube Wash Intervals

For setting the interval at which washing of the ink tubes will be carried out, in order to prevent ink clogging due to coagulation of ink inside the ink tubes.

- Important!**
- In order to perform tube washing with the Automatic Maintenance Function, the maintenance washing liquid needs to be set. If the maintenance washing liquid is not set, tube washing operation will not be regularly conducted and the passage could be clogged.

- 1 Press **FUNC1** (**MENU**) → **▼** → **ENTER** in LOCAL.
 - MAINTENANCE MENU will be displayed.
- 2 Press **▲** **▼** to select "AUTO MAINTENANCE", and press the **ENTER** key.
- 3 Press **▼**, and press **ENTER** .
 - "PUMP TUBE CLEANING" will be selected.
- 4 Press **▲** **▼** to set the tube washing interval, and press **ENTER** .
 - Set value : The set value will differ according to the ink type being used.
- 5 Press the **END/POWER** key several times to end the setting.

Setting the Cleaning Intervals and Type

The cleaning type and the interval between each cleaning operation are set.

- 1 Press **FUNC1 (MENU)** → **ENTER** in LOCAL.
 - MAINTENANCE MENU will be displayed.
 - 2 Press **▲▼** to select “**AUTO MAINTENANCE**”, and press the **ENTER** key.
 - 3 Press **▼** several times to select “**Interval**” or “**Type**”, and press the **ENTER** key.
 - 4 Press **▲▼** to select a set value, and press the **ENTER** key.
 - **Set value** : The set value will differ according to the ink type being used.
 - **Set value of type** : NORMAL/ HARD
-  When reactive dye ink Rc 400 or Rc 500 is used and the nozzle cleaning is stopped, the soft cleaning will be started.
- 5 Press the **END/POWER** key several times to end the setting.

Suspend the nozzle cleaning

When you want to work as such a printing during the nozzle cleaning, you can interrupt the nozzle cleaning.



- If the nozzle cleaning is interrupted, run the head cleaning without waiting for the configured cleaning time.

- 1 Press the **END/POWER** key during the nozzle cleaning implement.
 - Display the selection screen of the nozzle cleaning stop.

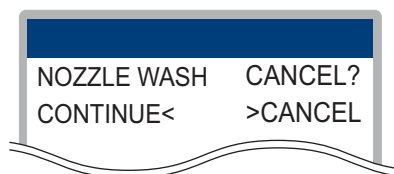

- 2 Press **▶** to select “**CANCEL**”.
 - If you want to continue the nozzle cleaning, please select [**◀**](CONTINUE).
 - "Soft" can also be set when reactive dye ink Rc 400 or Rc 500 is used.



Fill up Ink

Supplies ink to correct nozzle clogging.

- 1 Press **FUNC1 (MENU)** → **ENTER** in LOCAL.
 - MAINTENANCE MENU will be displayed.
- 2 Press **▲▼** to select “**FILL UP INK**”, and press the **ENTER** key.
- 3 Press **▲▼** to select the filling head, and press the **ENTER** key.
- 4 Press the **ENTER** key.
 - Ink is supplied automatically.
- 5 Press the **END/POWER** key several times to end the setting.

Replacing consumables

Use the supply items to replace parts if they are excessively dirty, damaged, or deformed.

To order replacement consumable items, contact your local dealer or our service office.

For more information on other consumable items, refer to our website. <https://mimaki.com/supply/inkjet.html>

Replacing the wiper

The wiper is consumable. When the display indicates the warning message "Replace a WIPER" it is necessary to check and replace the wiper, immediately replace the wiper with a new one. When cleaning the twin wiper, follow the procedure below.

Also, wipe ink sticking to the lower surface of the slider off. The wiper will differ depending on the particular machine model and ink sets. Replace the wiper as indicated in the following table.

Model	Ink set	Wiper	
		Product No.	Product Name
Tx300P-1800	----	SPA-0271	Wiper kit 300TS
Tx300P-1800 MkII	Other than the following	SPA-0271	Wiper kit 300TS
	Sb411+TP400/ Sb411+Sb420	SPA-0313	Wiper kit 300Tx-II



- Be sure to use the correct wiper corresponding to the usage conditions. Using the incorrect wiper may cause nozzle falling off.



- When the warning message for replacing wiper is shown, confirm whether there is no damage and fuzz at the top edge of the wiper film. If there is no damage on the top edge of the wiper film, it is possible to use the wiper continuously without replacing it.
- A cleaning wiper is an option. Buy one through the dealer in your region or at our service office.

1 Press **FUNC1 (MENU)** → **▼** → **ENTER** in **LOCAL**.

- MAINTENANCE MENU will be displayed.

2 Press the **ENTER** key.

- "STATION" will be selected.

3 Press **▲** **▼** to select "WIPER EXCHANGE", and press the **ENTER** key.

4 Press the **ENTER** key.

- The carriage will move onto the platen.

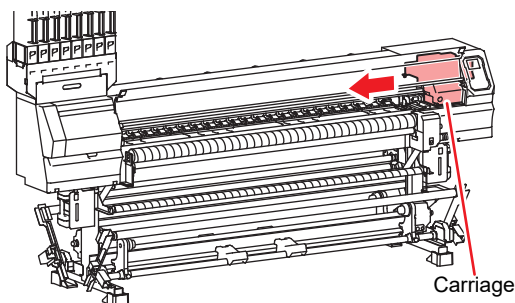

5 Open the front cover.

6 Remove the wiper.

- Pull out the wiper by holding the protrusions at its both ends.

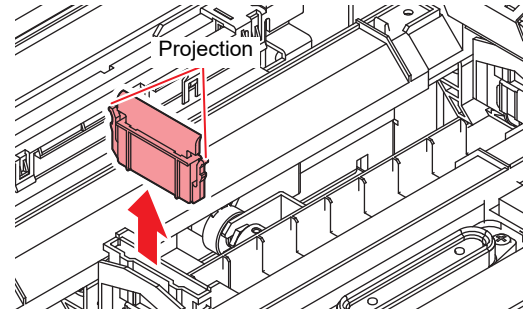

- For the twin wiper

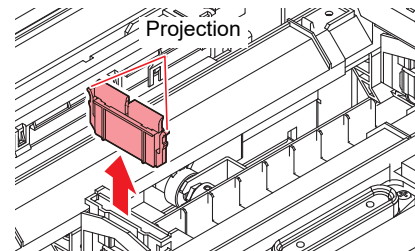

7 Insert a new wiper.

- Insert the wiper by holding the protrusions at its both ends.

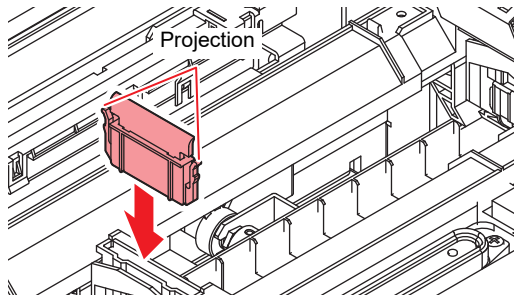

- For the twin wiper

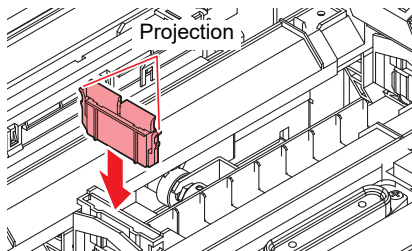

8 Close the front cover, and press the **ENTER** key.

- After its initial operation, the machine returns to LOCAL.

If a Waste Ink Tank Confirmation Message Appears

Ink used in head cleaning, etc. is stored in the waste ink tank on the lower right side of the machine. This machine counts the accumulated amount of discharged ink. When that reaches a specified amount, the machine displays a confirmation message. (When this message is displayed, consider the replacement of the waste ink tank.)



- The message is displayed when it reaches 80% (1.6L) of the 2L tank on the lower right side of the machine.



- The waste ink tank on the left does not cumulatively count the amount of discharge of such a substance as ink. Even if the level of dirty water in the tank becomes 80% or over, no message appears. Check the level of dirty water in the tank on the left often and dispose of dirty water if pooled.

Confirmation Message in LOCAL

1 The warning message "Check waste ink" is displayed.

2 Check the state of the waste ink tank

- For any difference between the displayed level and the actual level of discharge amount, carry out the operations described in and after step 3.
- If there is no difference between the displayed level and the actual level, and if you replace (dispose of) the waste ink tank, carry out the procedure described in "Replace the waste ink tank with another" (P.4-24)

3 Press **FUNC1** (MENU) → **ENTER** in LOCAL.

- MAINTENANCE MENU will be displayed.

4 Press **ENTER** to select "REPLACE WasteInkTank", and press the **ENTER** key.

5 If the amount of waste ink needs to be adjusted, press the **ENTER** key.

6 Press **ENTER** to adjust the level, and press the **ENTER** key.

7 Press the **ENTER** key.

Replace the waste ink tank with another

When the waste ink tank becomes full, carry out the procedure below to replace the waste ink tank, and in the Maintenance menu, set 0% for waste ink tank information. If you replace the waste ink tank before the waste ink tank confirmation message is displayed (before the 2L tank is 80% (1.6L) full), carry out the same procedure to replace the waste ink tank.

1 Press **FUNC1** (MENU) → **ENTER** in LOCAL.

- MAINTENANCE MENU will be displayed.

2 Press **ENTER** to select "REPLACE WasteInkTank", and press the **ENTER** key.

- Waste ink tank information is displayed.

3 Press **ENTER** to adjust the level, and press the **ENTER** key.

4 Press the **ENTER** key.

- The waste ink tank amount that is managed in this machine will be reset.

5 Pull the waste ink tank stopper to open to the front.

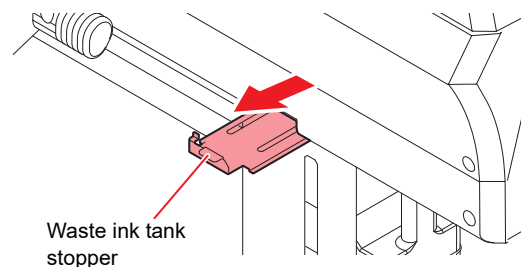

- 6** Pull it forward to remove by holding the waste ink tank handle.

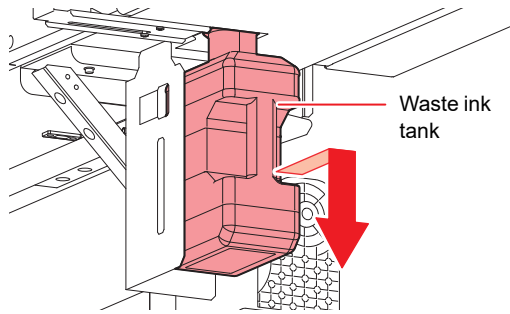

- Put a cap on the waste ink tank removed.

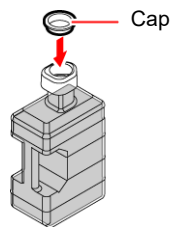

- 7** Replace the waste ink tank.

- (1) Prepare a new waste ink tank (SPA-0246).
- (2) Insert the waste ink tank by holding a handle of the tank.

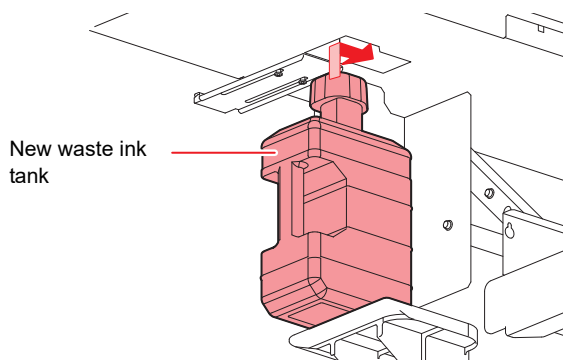

- Waste ink is equivalent to waste oil of industrial waste. Request an industrial waste disposal company for disposal of waste ink.

- 8** Close the waste ink tank stopper.

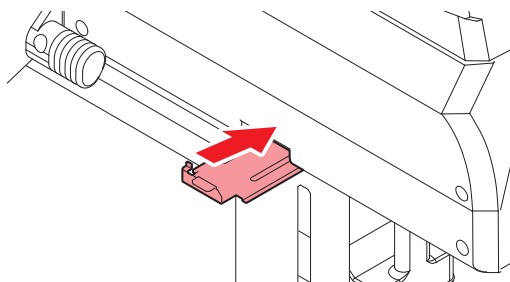

- 9** Press the **ENTER** key.

- The ink discharging amount that is controlled by the machine is reset and the message is canceled.

Replacing the Cap Absorber

Replacing the CAP ABSORBER KIT (PN:SPA-0314).

Replace the CAP ABSORBER KIT (PN: SPA-0314) when the warning message "Replace Cap Pad" is displayed on the local or guidance screen.

- 1** Press **FUNC1 (MENU)** → **ENTER** in LOCAL.

- MAINTENANCE MENU will be displayed.

- 2** Press **ENTER** → **FUNC3 (>>)** → **ENTER** key.

- "Replace Cap Pad" is selected.
- The carriage moves onto the platen.

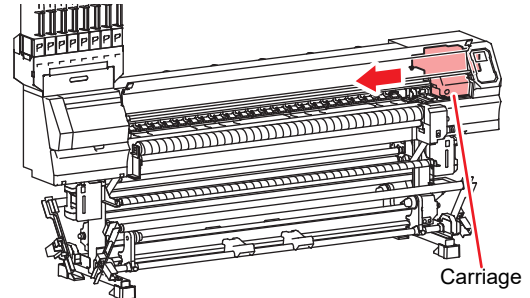

- 3** Open the front cover.

- 4** Remove the CAP ABSORBER KIT.

- Remove the processing hole of the cap absorber from the projection of the cap cover T and remove it.

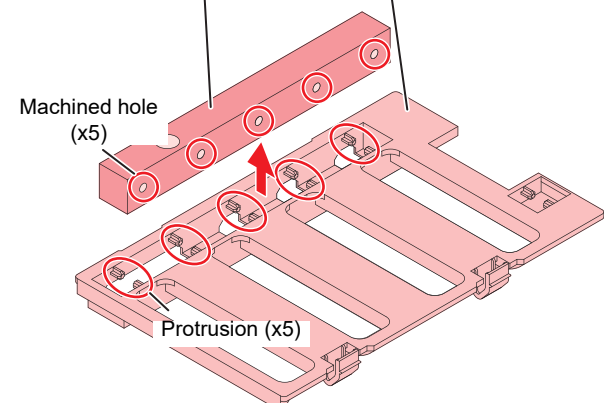
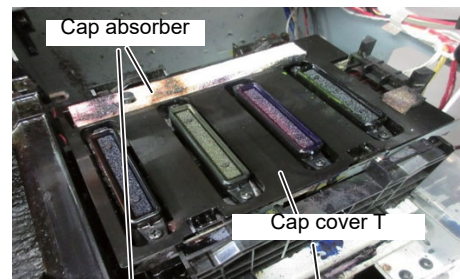

- 5** Insert a new CAP ABSORBER KIT.

- Align the processing hole of the cap absorber with the projection of the cap cover T, and attach it.
- Make sure the cap absorber is flat.
- Pull the cap absorber up to make sure it does not lift or come off.

6 When replacement is complete, press the **ENTER** key.

7 Close the front cover, and press the **ENTER** key.

- After its initial operation, the machine returns to step 1.

Replacing the CP PAD SET(PN:SPA-0314).

CP PAD SET(PN:SPA-0269) is a consumable item. If the dirt is severe or the ink falls off from the carriage, replace it.

1 Press **FUNC1** (MENU) → **ENTER** in LOCAL.

- MAINTENANCE MENU will be displayed.

2 Press the **ENTER** key twice.

- The carriage moves onto the platen.

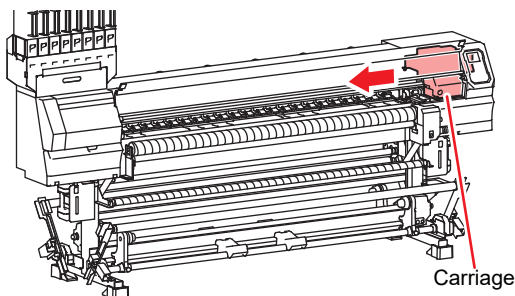

3 Open the front cover.

4 Remove the CP PAD SET.

- Remove the clasps at the front (2 points) and pull it out.

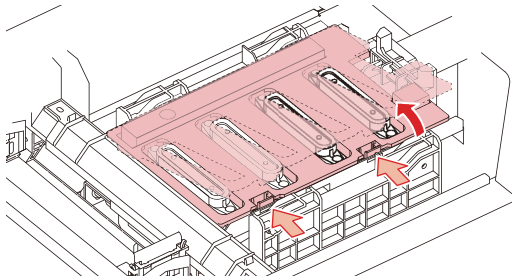

5 Insert a new CP PAD SET.

- Align the notches with the protrusions at the back and install it.

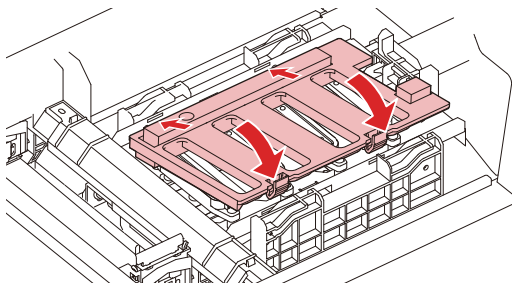

6 When replacement is complete, press the **ENTER** key.

7 Close the front cover, and press the **ENTER** key.

- After its initial operation, the machine returns to step 1.

Replacing the Blow down fan filter

Replace the Blow down fan filter (PN: SPC-0774) when it is dirty.

1 Remove the fan filter cover.

- Push the fan filter cover's tab outward, and pull the cover out toward you.

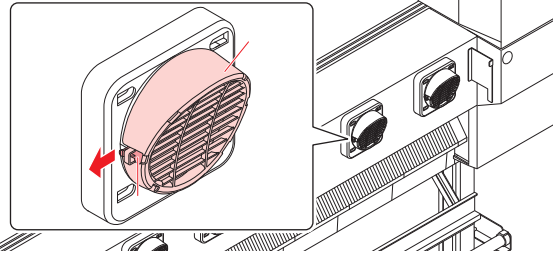

2 Remove the Blow down fan filter.

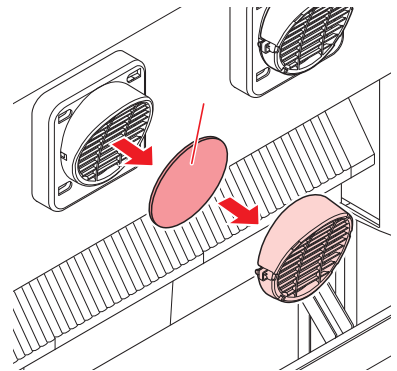

3 Attach a new Blow down fan filter and return the fan filter cover.

- Fit the fan filter cover on firmly, so that it clicks into place.

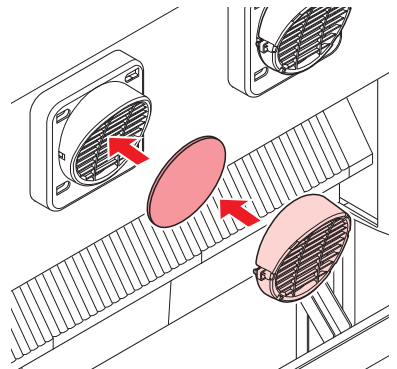

Replacing the Pinch roller

Replace the pinch roller (PN: SPA-0275) when it is worn or dirty.



- The pinch roller is an optional item. You can buy one through your local dealer or from our service office.
- Since the parts are small, you need to take extra care not to drop them into the gaps in the machine.



- When turning the main power switch off for moving the machine or for solving the error or the like, press the [END/POWER] key a long time on the front of the machine, check the display is turned off on the operation panel, and then turn the main power switch off.

1 Turn the power off, by giving the [END/POWER] a long press.

- If connected to a PC, disconnect first.

2 Turn off main power switch.

3 Open the front cover.

4 Raise the clamp lever to keep the pinch roller lifted.

5 Remove the O-ring retaining the pinch roller.

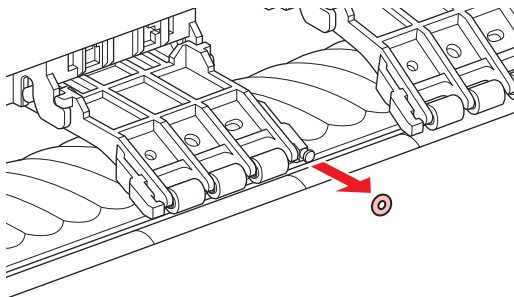

6 Remove the pinch roller.

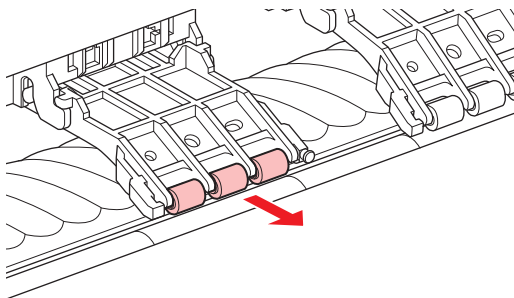

7 Insert a new pinch roller.

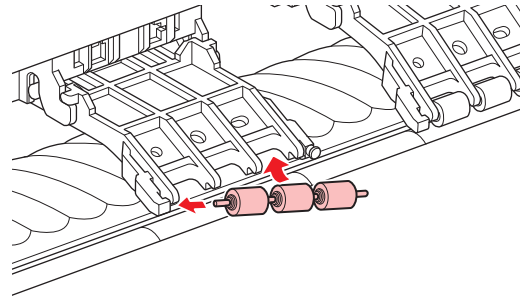

8 Insert a new O-ring.

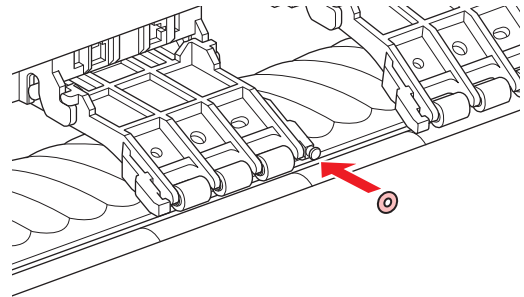

9 Close the front cover.

10 Turn the main power switch ON.

- (1) Set the main power switch located on the side of this machine to the "I" side.
 - When the power is turned on, the firmware version is displayed and the initial operation is executed.
- (2) [Press the [END / POWER] key to turn on the power.

Replacing the Spout Rubber

Install the spout rubber in an eco case in order to reduce ink leakage from the 2L ink pack.

The spout rubber is a supplied part. (SPA-0317: Set of 8 Rubber stopper 2L for case)

The replacing timing sign of the spout rubber will be shown about once every half-year. Please replace the spout rubber when you see the sign on the display.



- When exchanging 2L ink pack, be sure to wear the included safety glasses and gloves. Ink may spatter and get in your eyes accidentally.



Important!

- Replace all eight spout rubber. as a set at the same time.
- Depending on the usage environment and usage conditions, the spout rubber may deteriorate within half a year. If the gap in the center expands as shown in the picture, please replace it regardless of if there is a warning message.



The beginning of spout rubber



It is available to use



It is necessary to replace



- Reset the counter according to the following procedures if replacing any time other than when the warning is displayed.

- (1) Press the **FUNCTION** key in LOCAL to select "INFORMATION" and press the **ENTER** key.
- (2) Select "USAGE" and press the **ENTER** key.
- (3) Press the **FUNCTION** key.
- (4) If the following appears, press the **ENTER** key to reset the counter.

```
EcoCase/SpoutRubber
RESET? [ENT]
```

1

Open the 2L eco case.

2

Remove the 2L ink pack.

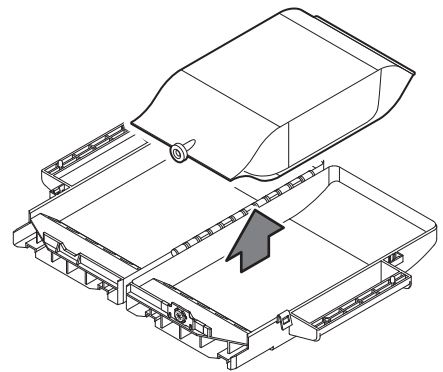

3

Remove the spout rubber assy.

- Press against the top of the spout rubber assy and pull it out vertically.

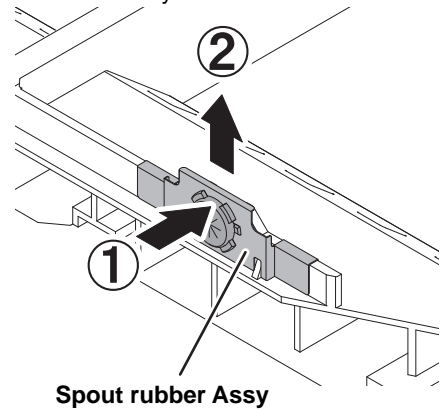

4

Attach the new spout rubber from outside of the eco-case.

- Insert it aligning the positioning protrusion of the spout rubber to the concave position of the eco-case.
- Be careful of the direction of the rubber when installing.
- Push the entire rubber into groove until the spout rubber fits evenly.



- Bending the entire spout rubber makes it easier to insert from the outside of the case.

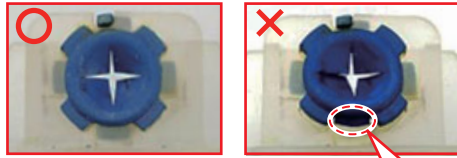
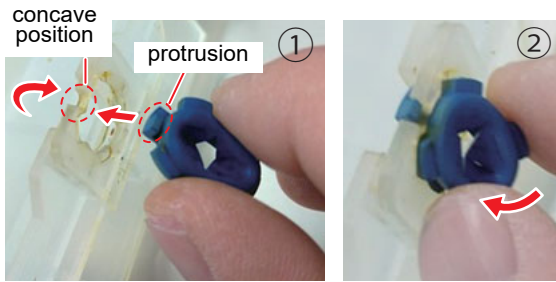

The ribs don't fit. If it is not seated in the groove correctly, the spout rubber will be damaged.

5 Moisten the surface of the spout rubber with maintenance solution sufficiently before inserting.

- Inserting the rubber into the eco-case without moistening may damage the rubber.
- In that case, use a maintenance solution that is suitable for the ink type.

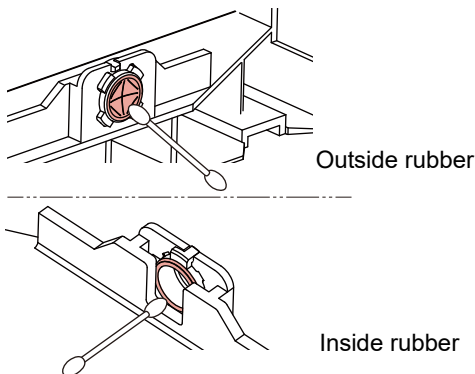

Male Connector Absorbent for MBIS

When replacing the 2L ink pack, you can prevent dirt from entering the cradle by periodically (5 to 10 times) replacing the male connector absorbent (accessory).



- Be sure to wear the supplied safety glasses and gloves when replacing the male connector absorbent.



- When the accessories are finished, please purchase from your local dealer or our sales office. (PN:SPA-0625)

1 Push down the lever attached to the cradle, and remove the 2L eco-case.

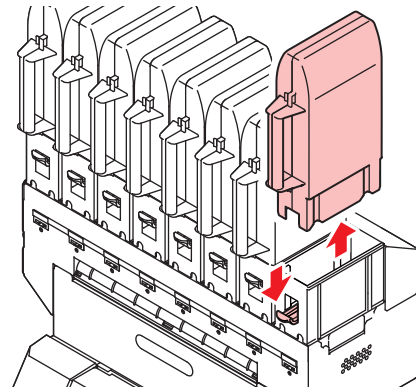

2 Remove the male connector absorbent.

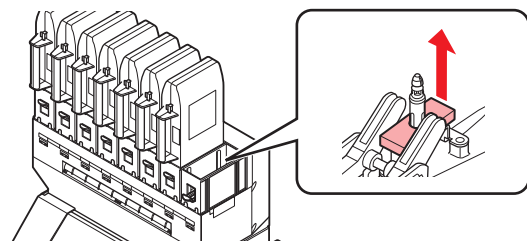

3 Insert the new male connector absorbent.

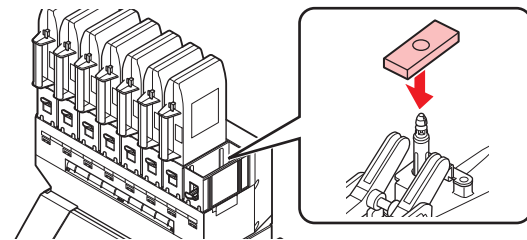

4 Install the 2L eco-case.

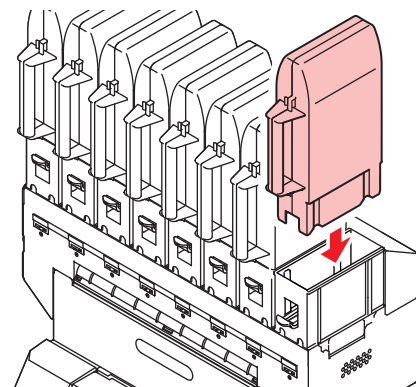

Chapter 5

Troubleshooting



This chapter

describes the corrective measures to be taken for a phenomenon suspected to be trouble and the procedures to clear the error number displayed on the LCD.

Troubleshooting	5-2
Power does not turn on	5-2
The machine does not start printing	5-2
Media get jammed / media is soiled	5-2
Image quality is poor	5-3
Nozzle is clogged	5-3
Ink IC warning appears.....	5-3
When the Ink Leakage Occurs	5-3
Warning / Error Messages	5-4
Warning messages.....	5-4
Error messages	5-7

Troubleshooting

Take appropriate actions as described below before taking the trouble as a failure.

If still the problem is not solved after troubleshooting, contact your dealer or an office of MIMAKI.

Power does not turn on

In most cases, this is due to improper connection of the power cable for the machine or computer. Check that the power cable is connected properly.

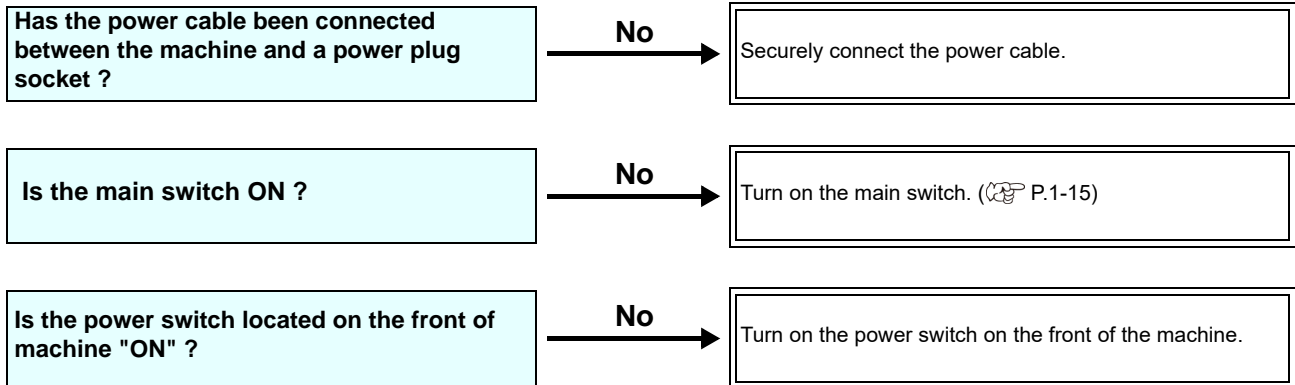

The machine does not start printing

This occurs when the data is not being transmitted to the machine properly.

It can also occur when the printing function does not work properly or the media is not set correctly.

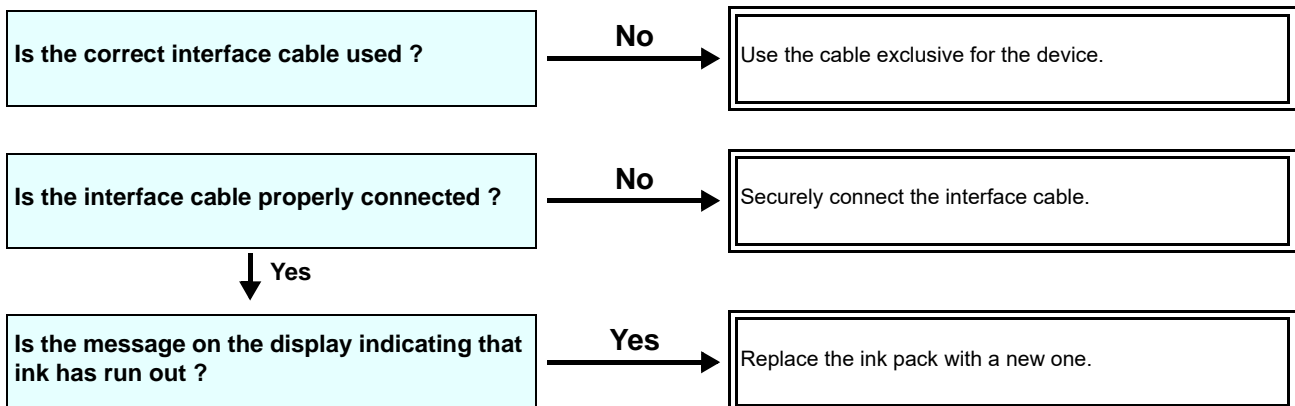

Media get jammed / media is soiled

Media jamming or stained media is considered to be due to the use of an unsuitable media or improper setting of media.

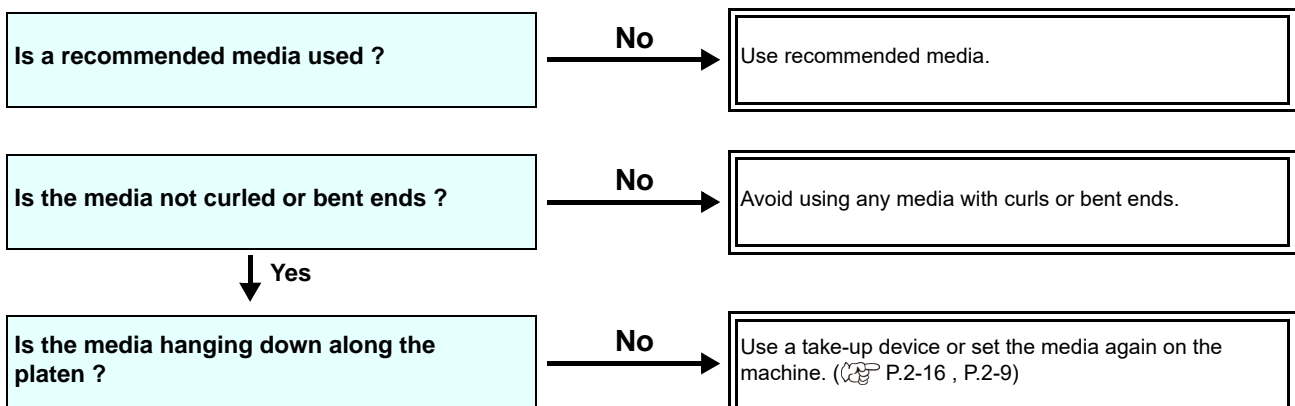

Image quality is poor

This section describes the corrective actions to be taken in case the image quality is not satisfactory.

Take remedy for particular problems with image quality. If the remedy does not work, contact your dealer or an office of MIMAKI.

Phenomenon	Measures
White lines / blur / dark stripes (in the direction of travel of the heads)	<ol style="list-style-type: none"> (1) Execute the head cleaning. (☞ P.2-29) (2) Perform maintenance of the inside of the station. (☞ P.4-10) (3) Execute the [FEED COMP.] function. (☞ P.3-5) (4) If any pieces of paper or dust is attached on the path of the heads such as media press, remove it.
Characters are double- or triple-printed in the media feed direction	<ol style="list-style-type: none"> (1) Execute the [FEED COMP.] function. (☞ P.3-5)
Disagreement in print positions between outward trip and homeward trip	<ol style="list-style-type: none"> (1) Execute the [DROP POSITION] function. (☞ P.3-6)
Ink drops falling on media during printing	<ol style="list-style-type: none"> (1) Execute the wiper cleaning. (☞ P.4-10) (2) Execute the ink cap cleaning. (☞ P.4-10) (3) Clean around the head. (☞ P.4-16) (4) Execute the head cleaning [NORMAL]. (☞ P.2-29) (5) Set the INTERVAL WIPING operation. (☞ P.3-11)

Nozzle is clogged

When nozzle clogging is not dissolved even after the head cleaning referring to P.2-29, make sure the following operations.

- Wash the head nozzle by the operations of P.4-12.
- Wash the head nozzle surface by the operations of P.4-16.
- Recovery the nozzle by the operations of P.4-18.

Ink IC warning appears

If an ink IC trouble is detected, the cartridge LED "red" is lit, and a warning message appears.

None of printing, cleaning and all the other operations that use ink is available.

In this case, replace the ink pack in question immediately.



- Once cartridge trouble is displayed, do not leave the ink pack without replacing it for a long time; otherwise, the machine will lose the nozzle clogging prevention function.

If nozzles are clogged, the machine must be repaired by MIMAKI's service engineer.

Displaying the description of ink IC trouble

The contents of IC error are confirmable by the following operations.

1

Press the **ENTER** key in LOCAL.

2

Press the **ENTER** key.

When the Ink Leakage Occurs

In case of ink leakage, please turn off the main power, unplug the power cable and contact your local distributor, our sales office, or service center.

Warning / Error Messages

If some trouble occurs, the buzzer sounds and the display shows a corresponding error message.

Take an appropriate remedy for the displayed error.

Warning messages

Errors when performing operations

Message	Cause	Solution
INVALID OPERATION :MEDIA UNDETECT	Operation cannot be performed because no media is detected.	<ul style="list-style-type: none"> Execute after media is detected.
INVALID OPERATION :MOTOR POWER OFF	The motor is OFF after the cover was opened etc.	<ul style="list-style-type: none"> Return to LOCAL and execute the operation after completion of initialization.
INVALID OPERATION INK ERROR	An ink error occurred.	<ul style="list-style-type: none"> Execute the operation after replacing with a new ink pack.
INVALID OPERATION COVER OPEN	The front cover or the maintenance cover is opened.	<ul style="list-style-type: none"> Execute the operation after closing the cover.
INVALID OPERATION DATA REMAIN	Data was received.	<ul style="list-style-type: none"> Execute the operation after executing data clear. (☞ P.2-33)
Please check Motor direct-connect unit	How direct-connection unit and torque limiter are attached does not match the settings for feeding/take-up tension bar.	<ul style="list-style-type: none"> To use tension bar, attach direct-connection unit. Otherwise, attach torque limiter (☞ P.2-9).

Message displayed in LOCAL

Message	Cause	Solution
Can't print/cartridge	Multiple ink errors (unusable ink) have occurred, making it impossible to feed ink (printing and cleaning, etc.).	Replace with a new ink pack.
Check waste ink	The waste ink tank count has exceeded the prescribed amount.	Check the amount of waste ink in the waste ink tank. Conduct maintenance and waste ink tank replacement, and reset the amount of waste ink.
Replace WIPER	The used count of wiper has exceeded the prescribed number.	Execute maintenance, station maintenance and wiper exchange and replace the wiper.
NO MEDIA	No media is set. Or, the sensor is faulty.	Set the media. If the same error message still appears after setting the media, contact your local distributor, our sales office, or service center.
DATA REMAIN	Print data is received in LOCAL.	Shift to REMOTE and execute printing. Or, execute data clear and cancel printing.
MACHINE TEMP./H ***°C	Stable printing cannot be done because temperature in the installed environment (printer) is too high.	Adjust the ambient temperature to within the specified scope (20°C to 35°C).
MACHINE TEMP./L ***°C	Stable printing cannot be done because temperature in the installed environment (printer) is too low.	

Message	Cause	Solution
Wash liquid cartridge none	The maintenance washing liquid cartridge is not set. Wiper washing and pump tube washing cannot be executed. (Auto maintenance operation)	Set the maintenance washing liquid cartridge.
Wash liquid end	There is no remaining maintenance washing liquid. Wiper washing and pump tube washing cannot be executed. (Auto maintenance operation)	Replace with a new washing liquid cartridge.
NCU SENSOR LEVEL LOW	The NCU sensor sensitivity is falling.	Replacement of the NCU is recommended. Contact your local distributor, our sales office, or service center.
NCU Sens Adj Err H	The sensitivity level of the sensor cannot be adjusted.	
NCU Sens Adj Err L		
Nozzle Missing Print Stopped	Because the nozzle check found nozzles missing, printing was stopped.	Perform head cleaning (☞ P.2-29) and deal with the nozzles clogging (☞ P.5-3).
NCU FLUSH POS Nozzle check OFF	Because an NCU-related error occurred during nozzle check, printing was stopped and the nozzle check function was turned OFF.	• Take steps according to the explanation for "ERROR 655 / NCU FLUSH POS".
NCU CENTER POS Nozzle check OFF		• Take steps according to the explanation for "ERROR 654 / NCU CENTER POS".
NCU SN ADJUST Nozzle check OFF		• Take steps according to the explanation for "ERROR 656 / NCU SN ADJUST".
NCU NZK CHK (HW) Nozzle check OFF		• Take steps according to the explanation for "ERROR 652 / NCU NZK CHK (HW)".
NCU NZK CHK (MARK) Nozzle check OFF		• Take steps according to the explanation for "ERROR 653 / NCU NZK CHK (MARK)".
NCU CONNECT	The NCU unit is not connected. The nozzle check function cannot be used.	• Turn off the power on the machine and turn it on after a while. If the same error message appears, contact your local distributor, our sales office, or service center.
REPLACE NCU	The NCU sensor sensitivity is too low to correctly judge nozzle missing. The nozzle check function cannot be used.	• NCU replacement is necessary. • Contact your local distributor, our sales office, or service center.
REPLACE NCU INK PAD	The NCU ink pad is full.	• It is necessary to replace the NCU ink pad. • Contact your local distributor, our sales office, or service center.
NCU ERROR Nozzle check OFF	Because an NCU-related error occurred during nozzle check, printing was stopped and the nozzle check function was turned OFF.	• Contact your local distributor, our sales office, or service center.
ADJUST HEAD HEIGHT	The head height setting saved in the machine and the current head height do not match.	• Set the head height. (☞ P.2-8)
Refill Ink	(Only for Sb411 + TP400 ink set) TP400 heads (HEAD 3, and 4) need to be cleaned to prevent ink clogging.	• Fill up with ink for HEAD 3, and 4. (☞ P.4-22)

Ink Error

Ink error is displayed also in the local guidance. (☞ P.3-28)

Message	Cause	Solution
WRONG INK IC	The IC chip of the ink pack cannot be read normally.	<ul style="list-style-type: none"> Remove the ink IC chip generating the warning once and install it again. If the same warning message still appears, contact your local distributor to call for service.
INK TYPE	The ink of the ink pack is different in type from the ink currently supplied.	<ul style="list-style-type: none"> Check the ink type of the cartridge generating the warning.
INK COLOR	The ink of the ink pack is different in color from the ink currently supplied.	<ul style="list-style-type: none"> Check the ink color of the cartridge generating the warning.
WRONG CARTRIDGE	An error occurred in the IC chip information of the ink pack.	<ul style="list-style-type: none"> Check the cartridge generating the warning. Make sure there is no nozzle clogging (Especially, white ink).
NO CARTRIDGE	An IC chip has not been installed in the slot.	<ul style="list-style-type: none"> Install an appropriate ink IC chip in the slot generating the warning.
INK END	The ink of the ink pack has been completely used up.	<ul style="list-style-type: none"> Replace the ink pack generating the warning with a new one.
INK NEAR END	There is only a little bit of ink left in the ink pack.	<ul style="list-style-type: none"> The ink will soon be used up. Be careful.
Expiration	The ink has expired.	<ul style="list-style-type: none"> Replace with new ink or use up as soon as possible. It is possible to print.
Expiration:1MONTH	One month has passed since the ink expired.	<ul style="list-style-type: none"> Replace with new ink or use up as soon as possible. It is possible to print.
Expiration:2MONTH	Two months have passed since the ink expired.	<ul style="list-style-type: none"> Replace with new ink. Cannot print.
ERROR 63c INK REMAIN ZERO	The expiration date of an ink pack has passed (two months have passed after the specified expiration date).	<ul style="list-style-type: none"> Replace the ink pack with a new one.
Vacuum Fan Err	The Vacuum Fan does not run (Only for Tx300P-1800 MkII)	<ul style="list-style-type: none"> Contact your local distributor, our sales office, or service center.
Replace Cap Pad	The amount of absorber used has exceeded the specified amount (use for one year). (Only for Tx300P-1800 MkII)	<ul style="list-style-type: none"> Replace the cap absorber. (☞ Replacing the CAP ABSORBER KIT(PN:SPA-0314). (P.4-25))

Error messages

When an error message is displayed, eliminate the error according to the chart below.
When displaying again, contact your dealer or an office of MIMAKI to call for service.

Message	Cause	Solution
ERROR 108 HD THERMIS[1234]	Head temperature control is defective.	<ul style="list-style-type: none"> Turn off the power on the machine and turn it on after a while. When displaying again, contact your local distributor, our sales office, or service center.
ERROR 108 HD CONNECT[1234]	An abnormality occurred in the head connection.	
ERROR 122 CHECK:SDRAM	SDRAM is defective.	
ERROR 128 HDC FIFO OVER	Head control circuit board is defective.	<ul style="list-style-type: none"> Turn off the power on the machine and turn it on after a while. When displaying again, contact your local distributor, our sales office, or service center.
ERROR 128 HDC FIFO UNDER		
ERROR 129 BATTERY EXCHANGE	The battery life end of the internal clock is detected.	
ERROR 12a HDC SPEED	An error was detected in the waveform being printed.	<ul style="list-style-type: none"> Turn off the power on the machine and turn it on after a while. When displaying again, contact your local distributor, our sales office, or service center.
ERROR 130 HD DATA SEQ		
ERROR 146 E-LOG SEQ	Sequential number abnormality of the event log occurred.	
ERROR 151 Main PCB V1R2	Error occurs in the power supply system of the main board.	
ERROR 152 Main PCB V2R5		
ERROR 153 Main PCB V3R3		
ERROR 154 Main PCB V05		
ERROR 157 Main PCB VTT		
ERROR 16e Main PCB V3R3B		
ERROR 15f HEAD DRIVE HOT		
ERROR 171 NEW HEAD CONNECT	An error occurred in the main PCB .	
ERROR 18a Main PCB V_CORE		
ERROR 18c Main PCB V12	An error occurred in the main PCB .	

Message	Cause	Solution
ERROR 18e FLS NOT COMP	An error was detected in the waveform being printed.	<ul style="list-style-type: none"> • Turn off the power on the machine and turn it on after a while. When displaying again, contact your local distributor, our sales office, or service center.
ERROR 18f OFFSET START		
ERROR 18f OFFSET END	An error was detected in the waveform being printed.	
ERROR 1d9 Main PCB V48-1	An error occurred in the main PCB .	
ERROR 1ce SLIDER PCB V24	An error occurred in the power supply of the slider PCB.	
ERROR 1cf SLIDER PCB V1R8		
ERROR 1de SLIDER PCB V1R2		
ERROR 1df SLIDER PCB V2R5		
ERROR 1e0 SLIDER PCB V3R3		
ERROR 1e1 SLIDER PCB V5		
ERROR 1e2 SLIDER PCB V48	An error occurred in the power supply of the first Station IV PCB.	
ERROR 1db Station4 PCB V48		
ERROR 1dc Station4 PCB V24		
ERROR 1dd Station4 PCB V24-A	An error occurred in the power supply of the second Station IV PCB.	
ERROR 1db Station4-2 PCB V48		
ERROR 1dc Station4-2 PCB V24		
ERROR 1dd Station4-2 PCB V24-A	The memory size is insufficient.	
ERROR 1e6 PRAM SIZE SHORTAGE		
ERROR 201 COMMAND ERROR	The machine received some data other than print data. Or, an error occurred in the transmitted print data.	<ul style="list-style-type: none"> • Securely connect the interface cable in position. • Use an interface cable conforming to the specifications.
ERROR 202 PARAMETER ERROR	An error occurred in the transmitted print data.	

Message	Cause	Solution	
ERROR 206 PRINTING MODE	Unable to print with the printing conditions of the print data received.	<ul style="list-style-type: none"> • Check the output conditions of the print data in the RIP software. • Check the profile. • When displaying again,, contact your local distributor to call for service. 	
ERROR 304 USB INIT ERR	An error occurred in the communication of USB.		
ERROR 305 USB TIME OUT			
ERROR 307 MCFD File IF Error	An error occurred during the access to the printing condition data.	<ul style="list-style-type: none"> • Turn off the power on the machine and turn it on after a while. When displaying again, contact your local distributor to call for service. 	
ERROR 401 MOTOR X	An excessive load was applied to the X motor.		
ERROR 402 MOTOR Y	An excessive load was applied to the Y motor.		
ERROR 403 X CURRENT	An error due to an excessive current of the X motor was detected.		
ERROR 404 Y CURRENT	An error due to an excessive current of the Y motor was detected.		
ERROR 423 TAKE-UP TENSION-BAR	Error in the take-up tension bar. <ul style="list-style-type: none"> • The tension bar origin could not be found. • No change could be seen in the tension bar angle. 		<ul style="list-style-type: none"> • Check the set state of the media. • Make sure that the media can be wound using the manual SW. Also, make sure that the tension bar rises. If it does not rise, adjust the counterweight. (P.2-11, P.2-9)
ERROR 425 Take-UP WRONG	A problem has occurred in the take-up tension bar. <ul style="list-style-type: none"> • The tension bar control position has deviated from the lowest point for a certain period. 		
ERROR 429 Take-UP LimitDETECT	Limit position of the take-up tension bar has been detected. <ul style="list-style-type: none"> • The tension bar control position has deviated from the highest point for a certain period. 		
ERROR 44f Take-UP Roll Sns Err	Roller sensor abnormality <ul style="list-style-type: none"> • The roller sensor cannot be correctly read. 	<ul style="list-style-type: none"> • Confirm that the take-up unit of machine setup and take-up tension bar setting are ON. (P.2-11) • Check the set state of the media. • Confirm that the winding unit operates using the manual SW. 	
ERROR 424 FEEDING TENSION-BAR	Error in the feeding tension bar. <ul style="list-style-type: none"> • The tension bar origin could not be found. • No change could be seen in the tension bar angle. 	<ul style="list-style-type: none"> • Check the set state of the media. • Make sure that the media can be wound using the manual SW. Also, make sure that the tension bar rises. If it does not rise, adjust the counterweight . 	
ERROR 426 FEEDING WRONG	A problem has occurred in the feeding tension bar. <ul style="list-style-type: none"> • The tension bar control position has deviated from the lowest point for a certain period. 		
ERROR 42a Feeding LimitDETECT	LIMIT position of the tension bar has been detected. <ul style="list-style-type: none"> • The tension bar control position has deviated from the highest point for a certain period. 		

Message	Cause	Solution
ERROR 450 Feeding Roll Sns Err	Feed sensor error. • The feed sensor could not be read correctly.	<ul style="list-style-type: none"> • Check that feeding unit and tension bar in machine setup are set to "ON" (☞ P.3-14). • Check how the media is set. • Check by Manual SW that feeding device can operate.
ERROR 505 MEDIA JAM	The media jam occurs.	<ul style="list-style-type: none"> • Remove the media and reset it.
ERROR 509 HDC POSCNT	An error occurred in the control position.	<ul style="list-style-type: none"> • Turn off the power on the machine and turn it on after a while. When displaying again, contact your local distributor, our sales office, or service center.
ERROR 50a Y ORIGIN	Y-origin could not be detected.	
ERROR 50f L-SCALE BLACK	Abnormal linear scale.	
ERROR 52c MEDIA WIDTH SENSOR	The media width could not be correctly read.	<ul style="list-style-type: none"> • Check the media set position. (☞ P.2-16) • Clean the media sensor. (☞ P.4-3) • Turn off the power on the machine and turn it on after a while.
ERROR 516 MEDIA SET POSITION R	The media is set outside the proper area.	<ul style="list-style-type: none"> • Check the media set position. (☞ P.2-16)
ERROR 528 PUMP MOTOR SENSOR	Pump sensor detection error	<ul style="list-style-type: none"> • Turn off the power on the machine and turn it on after a while. If the same error message appears, contact your local distributor, our sales office, or service center.
ERROR 52f CARRIAGE ORG	The carriage control origin is not set.	<ul style="list-style-type: none"> • Contact your local distributor, our sales office, or service center.
ERROR 530 STATION ORG	The station control origin is not set.	
ERROR 536 STATION LOCK	An error was detected in station operation.	<ul style="list-style-type: none"> • Turn off the power on the machine and turn it on after a while. If the same error message appears, contact your local distributor, our sales office, or service center.
ERROR 537 MAINT.WASH SHUTTER	An error was detected in cleaning solution shutter operation.	
ERROR 54c Vacuum Fan Err	The Vacuum Fan does not run. (Only for Tx300P-1800 MkII)	<ul style="list-style-type: none"> • Contact your local distributor, our sales office, or service center.
ERRR 550 CHECK PLATEN	The platen is not correctly set up.	<ul style="list-style-type: none"> • Check the media and platen combination in use, then set up the platen correctly. (☞ P.2-4) • If it appears again, please contact your local distributor, our sales office, or a service center.
ERROR 602 CARTRIDGE END	Ink end (cannot be used, can only be used when cleaning with the 4-color ink set)	<ul style="list-style-type: none"> • Replace with new ink.
ERROR 608 WRONG INK IC	The ink pack IC chip cannot be correctly read.	<ul style="list-style-type: none"> • Make sure that the cartridge is ink IC chip inserted. • Reinsert the ink IC chip. • Turn off the power on the machine and turn it on after a while. If the same error message appears, contact your local distributor, our sales office, or service center.

Message	Cause	Solution
ERROR 627 RE-INSERT CARTRIDGE	There is a slot in which the ink IC chip has not been inserted more than a certain time.	<ul style="list-style-type: none"> Set a ink IC chip.
ERROR 628 WRONG INK CARTRIDGE	A problem has occurred in the ink pack IC chip information. The used count has exceeded the prescribed value.	<ul style="list-style-type: none"> Make sure there is no nozzle clogging.
ERROR 63c INK REMAIN ZERO	Remaining ink is 0 in the cartridge (ink end/ only when the 4-color ink set is used))	<ul style="list-style-type: none"> Replace with new ink.
ERROR 64c NCU ERROR	The nozzle check has been suspended due to some problem.	<ul style="list-style-type: none"> Turn off the power on the machine and turn it on after a while. If the same error message appears, contact your local distributor, our sales office, or service center.
ERROR 650 NCU CONECT	The NCU unit is not connected.	
ERROR 651 REPLACE NCU	The NCU sensor sensitivity is too low to correctly judge nozzle missing. The nozzle check function cannot be used.	<ul style="list-style-type: none"> The NCU needs to be replaced. Contact your local distributor, our sales office, or service center.
ERROR 652 NCU NZK CHK (HW)	The NCU cannot correctly recognize the ink discharge, because there are frequent nozzle missing and ink droplet misalignment.	<ul style="list-style-type: none"> Check the state of the nozzles, and if there are frequent nozzle missing and ink droplet misalignment, conduct cleaning to restore.
ERROR 653 NCU NZK CHK (MARK)		
ERROR 654 NCU CENTER POS		
ERROR 655 NCU FLUSH POS	Adjustment of the discharge position to the NCU has failed.	
ERROR 656 NCU SN ADJST	Sensor sensitivity adjustment has failed.	<ul style="list-style-type: none"> Check the state of the nozzles, and if there are frequent nozzle missing and ink droplet misalignment, conduct cleaning to restore. If the same error message still appears after restoring the state of the nozzles, contact your local distributor, our sales office, or service center.
ERROR 657 REPLACE NCU INK PAD	The NCU ink pat is full.	<ul style="list-style-type: none"> Contact your local distributor, our sales office, or service center.
ERROR 658 NCU SENSOR LV LOW	THE sensitivity level of the NCU sensor is low.	<ul style="list-style-type: none"> Replacement of the NCU is recommended. Contact your local distributor, our sales office, or service center.
ERROR 65b NCU Sens Adj Err H	The sensitivity level of the sensor cannot be adjusted.	
ERROR 65c NCU Sens Adj Err L		
ERROR 901 INVAILD OPERATION	Due to a certain error, the function cannot be performed.	<ul style="list-style-type: none"> Return to the local screen, check the error status and take a countermeasure.
ERROR 902 DATA REMAIN	There remains received data that has not yet been printed.	<ul style="list-style-type: none"> Execute the data clear function. (☞ P.2-33)
ERROR 90d NO HEAD SELECT	An error occurred in the mounted heads.	<ul style="list-style-type: none"> Turn off the power on the machine and turn it on after a while. When displaying again, contact your local distributor, our sales office, or service center.

Message	Cause	Solution
ERROR 90f PRINT AREA SHORT	The media width or the media length required for printing is not enough.	<ul style="list-style-type: none"> • Change the media to the one with enough width or length. • When the media width narrows because the origin moved, slide the origin to the right to widen the effective media width.
ERROR 91a ADJUST HEAD HEIGHT	The head height setting saved in the machine and the current head height do not match.	<ul style="list-style-type: none"> • Set the head height. (☞ P.2-8)
ERROR 04 PARAM ROM	An error occurred in the main PCB FROM.	<ul style="list-style-type: none"> • Turn off the power on the machine and turn it on after a while. When displaying again, contact your local distributor, our sales office, or service center.
ERROR d01 HCB POWER [1234]	An error occurred in the power supply of the HCB PCB.	
ERROR d02 HCB COMMON [1234]	An error was detected in the HCB PCB.	
ERROR d03 HCB HARD [1234]		
ERROR d04 HCB CMD [1234]	An error was detected in the HCB PCB communication.	
ERROR d05 HCB WFM [1234]	An error was detected in the waveform being printed.	
ERROR d06 HCB VUP [1234]	A failure to update the HCB PCB was detected.	
ERROR d07 HCB FAN [1234]	An error occurred in the HCB board fan.	
ERROR d08 HCB UKNWN [1234]	An unknown error was detected from the HCB board.	
ERROR d09 HD MEMORY [1234]	An abnormality was detected from the head built-in memory.	
ERROR d0a HCB BUSY [1234]	An error occurred in the communication between the HCB board and the slider P board.	

SYSTEM HALT

Message	Solution
SYSTEM HALT (*) 000 : MESSAGE	<ul style="list-style-type: none"> • Turn off the power on the machine and turn it on after a while. • When displaying again,, check the number and contact your local distributor to call for service. ("000" is the error No.)
SYSTEM HALT (*) 406 : WIPER ORG	<ul style="list-style-type: none"> • Perform cleaning around the wiper. • Turn off the power on the machine and turn it on after a while. • When displaying again, contact your local distributor, our sales office, or service center.

Chapter 6

Appendix



This chapter

contains the lists of the specifications and functions of this machine.

Specifications	6-2
Machine specifications	6-2
Ink specifications	6-4
Setting orders of ink cartridges	6-5
Sheet for inquiry	6-6

Specifications

Machine specifications

Item		Tx300P-1800/Tx300P-1800 MkII (cloth media)	Tx300P-1800 MkII (transfer paper)
Print head	Method	Drop-on-demand piezoelectric print heads	
	Specification	4-Head Inline	
Printing mode (scan x feed)		540 × 360 dpi/ 540 × 540 dpi/ 540 × 720 dpi/ 720 × 720 dpi/ 720 × 1080 dpi/ 720 × 1440 dpi *1	
Usable inks		Sublimation dye ink : Sb420, Sublimation dye ink : Sb421, Textile pigment ink : TP400, Disperse dye ink :Dd400, Acid-dye ink : Ac400, Reactive-dye ink : Rc400, Rc500, Sublimation dye Transfer ink : Sb411(Tx300P-1800 MkII Only)	
Ink supply		Supplying from ink packs through tubes. Ink pack replacement type : Supplying by Toggle switch over with 2 packs/color (4-colors ink set/ 6-colors ink set: M, BI)	
Capacity of ink pack	4-colors	Y, M, BI, K (Sb420): 2L-ink pack x 2 for each color	
		Y, M, BI, K (Sb421): 2L-ink pack x 2 for each color	
		Y, M, C, K (TP400): 2L-ink pack x 2 for each color	
	6-colors	Y, K, LBI, Lm: 2L-ink pack x 1 for each color M,BI: 2L-ink pack x 2 for each color	
		M, R, BI, C, Y, Lk: 2L-ink pack x 1 for each color K: 2L-ink pack x 2	
	8-colors	M, R, C, Gr, Y, K, V, P (Dd400): 2L-ink pack x 1 for each color	
		M, R, BI, C, Y, Or, K, Lk (Ac400): 2L-ink pack x 1 for each color	
		M, R, BI, C, Y, Or, K, Lk (Rc400): 2L-ink pack x 1 for each color	
		M, R, BI, C, Y, Or, K, Lk (Rc500): 2L-ink pack x 1 for each color	
	4 + 4-colors	Y, M, BI, K (Sb420): 2L-ink pack x 1 for each color Y, M, C, K (TP400): 2L-ink pack x 1 for each color	
		Y, M, BI, K (Sb421): 2L-ink pack x 1 for each color Y, M, C, K (TP400): 2L-ink pack x 1 for each color	
		Y, M, BI, K (Sb411): 2L-ink pack x 1 for each color (Tx300P-1800 MkII Only) Y, M, C, K (TP400): 2L-ink pack x 1 for each color	
Y, M, BI, K (Sb411): 2L-ink pack x 1 for each color (Tx300P-1800 MkII Only) Y, M, BI, K (Sb420): 2L-ink pack x 1 for each color			
Usable media		Polyester, cotton, silk etc. (Except the expansion and contraction media.)	Transfer paper
Max. printing width		1,920 mm (75.6 in)	1,940 mm (76.4 in)

Item		Tx300P-1800/Tx300P-1800 MkII (cloth media)	Tx300P-1800 MkII (transfer paper)	
Roll Media size	Maximum	1,920 mm (75.6 in)	1,950 mm (76.8 in)	
	Minimum	210 mm (8.3 in)	210 mm (8.3 in)	
	Thickness	1.0 mm or less (0.039 in or less)		
	Printing surface	Regardless of faces in and out	Side facing outward	
	Feed	Roll outside diameter	Φ 250 mm or less (Φ 9.8 in or less) Media edge Guide: Φ200mm(Φ7.87 in) or less. *3	
		Roll weight	40 kg or less (88.2 lb or less)	
		Roll inside diameter	2 or 3 inches	
	Take-up	Roll outside diameter	Φ 250 mm or less (Φ 9.8 in or less) Media edge Guide: Φ200mm(Φ7.87 in) or less. *3	
		Roll weight	40 kg or less (88.2 lb or less)	
		Roll inside diameter	2 or 3 inches	
		Roll end treatment	The roll end is gently fixed to the core with weak-adhesive tape or weak glue for easy removal.	
		Winding misalignment	~ φ 120 mm(4.8 in) : ± 1 mm (0.04 in) ~ φ 170 mm(6.7) : ± 3 mm (0.12 in) ~ φ 200mm(7.9) : ± 5 mm (0.2) (When using the media edge guide : Tx300P-1800 MkII Only)	
Leaf media size	Maximum	1,920 mm (75.6 in)		
	Minimum	210 mm (8.3 in)		
Margin	Leaf media	Left end and right end: 20 mm (Default) Front:120 mm Rear: 150 mm (Left end and right end: 0.8 in (Default) Front: 4.7 in Rear: 5.9 in)		
	Roll media	Left end and right end: 20 mm (Default) Front:120 mm Rear: 150 mm (Left end and right end: 0.8 in (Default) Front: 4.7 in Rear: 5.9 in)		
Distance accuracy	Absolute accuracy	Whichever the larger one of ± 0.3 mm or ± 0.3% of the designated (Whichever the larger one of ± 0.01 in or ± 0.3% of the designated)		
	Reproducibility	Whichever the larger one of ± 0.2 mm or ± 0.1% of the designated (Whichever the larger one of ± 0.008 in or ± 0.1% of the designated)		
Perpendicularity		± 0.5 mm / 1,000 mm (± 0.02 in / 39.4 in)		
Media skew		5 mm or less / 10 m (0.2 in or less / 32.8 ft)		
Head height adjustment		2 mm to 7 mm, can be freely adjusted manually (0.08 in to 0.28 in, can be freely adjusted manually)		
Media delivery		Take-up device supplied as a standard accessory (switching possible between face in and face out).		
Waste ink tank		Bottle type: 2,000 cc (2 liters) x2		
Interface	Print data transmission function	USB 2.0, Ethernet 1000BASE-T		
	Mail function	Ethernet 10 BASE-T / 100 BASE-TX / 1000BASE-T		
Command		MRL- V		
Noise	during standby	Less than 58 dB (A) (FAST-A, Front & Rear & Left & Right 1 m (39.4 in))		
	during continuous printing *2	Less than 65 dB (A)		
	during discontinuous printing	Less than 70 dB (A)		
Safety Standard		VCCI-Class A, FCC-Class A, UL 60950, CE Marking (EMC, Low Voltage Directive, Machinery Directive, RoHS Directive), CB Report, RoHS		
Power		AC 100 - 120 V/ 200 - 240 V 12 A/8 A 50/60 Hz		
Power consumption		1,440 W (AC 100 - 120 V), 1,920 W (AC 200 - 240 V)		
Recommended Environment	Available temp.	20 °C to 30 °C (68 °F to 86 °F)		
	Humidity	35 to 65% Rh (No condensation)		
	Guaranteed temp.	20 °C to 25 °C (68 °F to 77 °F)		
	Temperature change	± 10 °C / h or less (± 50 °F / h or less)		
	Dust	Equivalent to normal office level		
	Highest operation height	2,000 m (6,561.7 ft)		

Item		Tx300P-1800/Tx300P-1800 MkII (cloth media)	Tx300P-1800 MkII (transfer paper)
Weight		255 kg (562.2 lb) 260 kg (573.0 lb) (Tx300P-1800 MkII)	
Outside dimensions	Width	3,197 mm (125.9 in)	
	Depth	965 mm (38.0 in)	
	Height	1,857 mm (73.1 in)	

*1. The available printing modes differ depending on the type of ink to be used.

*2. Operating Condition: Full load Measuring Method: According to clause 1.7.4.2 of Machinery Directive 2006/42/EC

*3: Use within dia.200mm to 120mm. (It varies depending on the position of the media edge guide.)

Ink specifications

Item	Sublimation dye ink Sb420	Sublimation dye ink Sb421	Sublimation dye transfer ink Sb411	Textile Pigment ink TP400	Disperse dye ink Dd400	Acid-dye ink Ac400	Reactive-dye ink Rc400	Reactive-dye ink Rc500
Supply	2 liters ink pack							
Color	Black (K) Blue (Bl) Magenta (M) Yellow (Y) Light blue (LBl) Light magenta (Lm)	Black (K) Blue (Bl) Magenta (M) Yellow (Y)	Black (K) Blue (Bl) Magenta (M) Yellow (Y)	Black (K) Cyan (C) Magenta (M) Yellow (Y) Red (R) Blue (Bl) Light black (Lk)	Black (K) Cyan (C) Magenta (M) Yellow (Y) Red (R) Gray (Gr) Violet (V) Pink (P)		Black (K) Cyan (C) Blue (Bl) Magenta (M) Yellow (Y) Orange (Or) Red (R) Light black (Lk)	
Ink capacity	2 liters							
Shelf life	The period is printed on the ink pack. Within three months after opening the package even in the available period.							
Storage temperature	Storage	Average daily temperature: 10 to 35 °C (50 to 95 °F) Be sure to keep a vessel in the airtight condition. Be sure to keep a vessel in a dry, well-ventilated, cool and dark location.						
	Transportation	0 to 40 °C (32 to 104 °F) Avoid the condition lower than -0 °C (32 °F) and higher than 40 °C (104 °F).						



- Do not disassemble ink packs and 2L eco case and do not refill them with ink.
- Ink could freeze if kept in a cold place for an extended period.
- When aqueous ink is used, if the ink freezes, the quality is changed and the ink becomes unusable.
Store the ink in an environment that will not freeze the ink.

Setting orders of ink cartridges

The orders of ink cartridges set in the ink station differ depending on the ink set you use.



- Set the ink cartridge according to the cartridge label under the ink station.

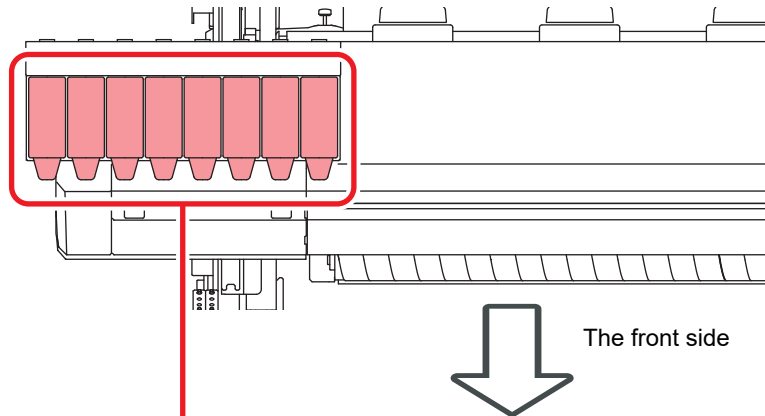

4-colors model	Dye Sublimation ink: Sb420	M	M	BI	BI	Y	Y	K	K
	Dye Sublimation ink: Sb421	M	M	BI	BI	Y	Y	K	K
	Textile Pigment ink: TP400	M	M	C	C	Y	Y	K	K
6-colors model	Dye Sublimation ink: Sb420	M	M	BI	BI	Y	K	LBI	Lm
	Dye Sublimation ink: Sb421	M	M	BI	BI	Y	K	LBI	Lm
7-colors model	Textile Pigment ink: TP400	M	R	BI	C	Y	Lk	K	K
8-colors model	Disperse dye ink: Dd400	M	R	C	Gr	Y	K	V	P
	Acid-dye ink: Ac400	M	R	BI	C	Y	Or	K	Lk
	Reactive-dye ink: Rc400	M	R	BI	C	Y	Or	K	Lk
	Reactive-dye ink: Rc500	M	R	BI	C	Y	Or	K	Lk
4 + 4-colors model	Dye Sublimation ink: Sb420 Textile Pigment ink: TP400	Sb420				TP400			
		M	BI	Y	K	M	C	Y	K
	Dye Sublimation ink: Sb421 Textile Pigment ink: TP400	Sb421				TP400			
		M	BI	Y	K	M	C	Y	K
	Dye Sublimation transfer ink: Sb411 Textile Pigment ink: TP400	Sb411				TP400			
		M	BI	Y	K	M	C	Y	K
Dye Sublimation transfer ink: Sb411 Sublimation dye ink: Sb420	Sb411				Sb420				
	M	BI	Y	K	M	BI	Y	K	



- When you use the wiper, the cleaning solution cartridge, please refer to the following.
 - P.4-3 "About Cleaning Solution"
 - P.4-23 "Replacing the wiper"

Sheet for inquiry

Use this sheet for troubles and abnormal functions of the machine.
Fill in the following necessary items, and then fax the sheet to our sales office.

Company name	
Person in charge	
Telephone number	
machine model	
Operating OS	
Machine information *1	
Error message	
Contents of inquiry	

*1. Refer to "Confirming Machine information" of "Convenient using" then fill in necessary information. (👉 P.3-27)

Tx300P-1800/Tx300P-1800 MkII Operation Manual

May, 2022

MIMAKI ENGINEERING CO.,LTD.
2182-3 Shigeno-otsu, Tomi-shi, Nagano 389-0512 JAPAN

D202937-34-10052022

